

On a new class of elastic deformations not allowing for cavitation

by

S. MÜLLER (*), (***)

Institut für Angewandte Mathematik,
Universität Bonn,
Berlingstrasse 4, D-53115 Bonn, Germany

Tang QI (**), (***)

Department of Mathematics,
University of Sussex,
Brighton, BN1 9QH, U.K.

and

B. S. YAN

Department of Mathematics,
University of Minnesota,
206 Church Street S.E.,
Minneapolis, MN 55455, U.S.A

ABSTRACT. — Let $\Omega \subset \mathbb{R}^n$ be open and bounded and assume that $u: \Omega \rightarrow \mathbb{R}^n$ satisfies $u \in W^{1,p}(\Omega, \mathbb{R}^n)$, $\text{adj} Du \in L^q(\Omega; \mathbb{R}^{n \times n})$ with $p \geq n-1$, $q \geq \frac{n}{n-1}$. We show that for $g \in C^1(\mathbb{R}^n; \mathbb{R}^n)$ with bounded gradient, one

Classification A.M.S. : 73 C 50, 26 B 10, 49 A 21.

(*) Research partially supported by the N.S.F. under grant DMS-9002679 and by SFB256 at the University of Bonn.

(**) Research partially supported by grant SCI/180/91/220/G from the Nuffield Foundation.

(***) This work was initiated while S. Müller and Qi Tang visited the I.M.A. at Minneapolis under the programme on Phase transitions and free boundary problems.

has the identity $\frac{\partial}{\partial x^j} \{ (g^i \circ u) (\text{adj } Du)_i^j \} = (\text{div } g) \circ u \det Du$ in the sense of distributions. As an application, we obtain existence results in nonlinear elasticity under weakened coercivity conditions. We also use the above identity to generalize Šverák's (cf. [Sv88]) regularity and invertibility results, replacing his hypothesis $q \geq \frac{p}{p-1}$ by $q \geq \frac{n}{n-1}$. Finally if $q = \frac{n}{n-1}$ and if $\det Du \geq 0$ a.e., we show that $\det Du \ln(2 + \det Du)$ is locally integrable.

RÉSUMÉ. — Soit $\Omega \subset \mathbb{R}^n$ un ouvert borné et soit $u: \Omega \rightarrow \mathbb{R}^n$ une application dans $W^{1,p}(\Omega; \mathbb{R}^n)$ avec $\text{adj } Du \in L^q(\Omega; \mathbb{R}^{n \times n})$ et $p \geq n-1$, $q \geq \frac{n}{n-1}$. On

montre l'identité $\frac{\partial}{\partial x^j} \{ (g^i \circ u) (\text{adj } Du)_i^j \} = (\text{div } g) \circ u \det Du$ au sens de distributions si $g \in C^1(\mathbb{R}^n; \mathbb{R}^n)$ avec gradient borné. Par conséquent on obtient des nouveaux résultats d'existence en élasticité non linéaire. On obtient aussi une généralisation de résultats de Šverák sur la régularité et l'invertibilité en remplaçant l'hypothèse $q \geq \frac{p}{p-1}$ par $q \geq \frac{n}{n-1}$. Finalement si

$q = \frac{n}{n-1}$ et $\det Du \geq 0$ p.p. on montre que $\det Du \ln(2 + \det Du)$ est localement intégrable.

1. INTRODUCTION

Let Ω be a bounded open set in \mathbb{R} . In this paper we study the properties of maps $u: \Omega \rightarrow \mathbb{R}^n$ which belong to the Sobolev spaces $W^{1,p}(\Omega; \mathbb{R}^n)$ for "low" values of p and discuss applications to nonlinear elasticity. There is a striking difference in the behaviour of such maps for different values of p . If $p > n$, then u behaves, in many ways, like a Lipschitz or even C^1 map. Specifically, it has a continuous representative, maps null sets onto null sets, the area formula holds (see Marcus and Mizel [MM73]), global topological arguments apply (see Ball [Ba81] and Ciarlet and Necas [CN87]) and the Jacobian $\det Du$ is weakly (sequentially) continuous as a map from $W^{1,p}$ to $L^{p/n}$ (see Reshetnyak [Re67] and Ball [Ba77]).

By contrast, many of these properties may fail if $p \leq n$. Besicovitch [Be50] constructed a continuous map from the closed unit disk $\bar{D} \subset \mathbb{R}^2$ to \mathbb{R}^3 which is in $W^{1,2}(D; \mathbb{R}^3)$ and whose image has positive three-dimensional Lebesgue measure. More recently Maly and Martio [MM92] have resolved a long-standing question by giving an example of a continuous map $u \in W^{1,n}(\Omega; \mathbb{R}^n)$ satisfying $\det Du = 0$ a.e. for which $u(\Omega)$ has positive measure. Counterexamples to the weak continuity of the Jacobian were given by Ball and Murat [BM84]. Müller, Spector and Tang [MST91] gave another example that topological arguments may fail drastically by constructing a map satisfying $u \in W^{1,p}(D; \mathbb{R}^2)$ for all $p < 2$ with $u|_{\partial D} = \text{id}$ such that u is injective on $D \setminus N$ (where N is a null set) and such that the image of u contains sets of positive measure both in D and in $\mathbb{R}^2 \setminus \bar{D}$. Here care has to be taken with the definition of the image but the pathology occurs with all reasonable definitions, see the paper quoted above for details.

The study of maps in $W^{1,p}$ with $p < n$ is of great interest in nonlinear elasticity. First, for commonly used stored-energy density functions, there exist deformations with finite energy which are not in $W^{1,n}$ (cf. the discussion in [Ba77]). Secondly, Ball [Ba82] has shown that in these function classes, discontinuous equilibrium solutions with a discontinuity corresponding to the formation of a cavity can occur. The functions studied there are of the following type [$B(0, r)$ denotes the ball in \mathbb{R}^n with center 0 and radius r]

$$u: x \rightarrow \mathbb{R}(|x|) \frac{x}{|x|} : B(0, 1) \rightarrow B(0, R(1))$$

with $R(t) > 0$, $R'(t) > 0$, $R(0) > 0$.

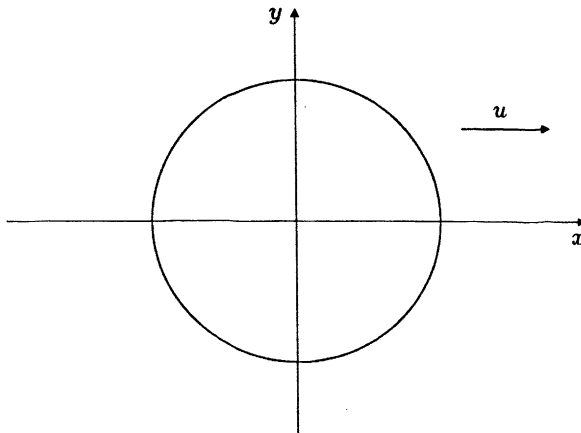

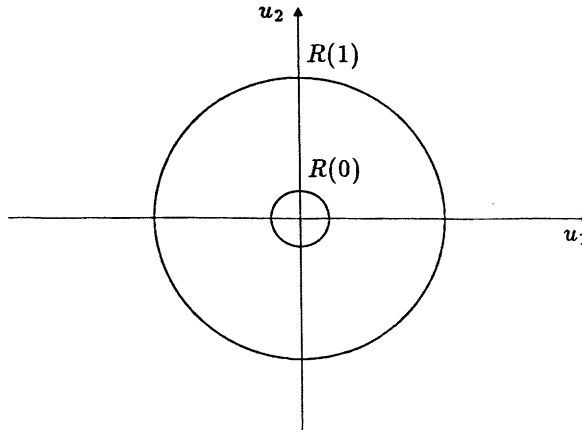

An existence theorem in that class is still outstanding due to the failure of weak continuity of the Jacobian. Therefore Ball's methods do not apply directly.

In the current work we do not attack that problem (*see* Müller and Spector [MS92] for some progress in that direction) but rather extend previous weak continuity and regularity results thus allowing for weaker growth conditions in the existence theory. Following Ball [Ba77] and Šverák [Sv88], we consider function classes which involve not only information on the gradient Du but also on its adjugate matrix (the transpose of the cofactor matrix) $\text{adj } Du$. Geometrically $\text{adj } Du$ controls the deformation of (codimension 1) surface elements while Du controls the deformation of line elements. In the context of elasticity, certain commonly used stored-energy densities (like those proposed by Ogden [Og72]) lead to, in their simplest form, an energy density of the form

$$W(F) = \alpha |F|^p + \beta |\text{adj } F|^q + h(\det F), \quad (1.1)$$

where $\alpha, \beta > 0$ and where h is a non-negative and convex function. We thus consider the function classes

$$\begin{aligned} A_{p,q}(\Omega) &= \{u \in W^{1,p}(\Omega; \mathbb{R}^n) : \text{adj } Du \in L^q(\Omega; \mathbb{R}^{n \times n})\}, \\ A_{p,q}^+(\Omega) &= \{u \in A_{p,q}(\Omega) : \det Du > 0 \text{ a.e.}\}, \end{aligned}$$

the latter class being motivated by the fact that a deformation of an elastic body should be orientation preserving. In his remarkable paper, Šverák [Sv88] showed that if $u \in A_{p,q}(\Omega)$ with $p \geq n-1$, $q \geq \frac{p}{p-1}$ and if the trace $u|_{\partial\Omega}$ satisfies certain regularity and continuity conditions then the following

degree formula holds (see section 2 and [Sc69] for the definition of the Brouwer degree)

$$\int_{\Omega} (f \circ u) \det Du \, dx = \deg(u, \partial\Omega, y_0) \int_{\mathbb{R}^n} f(y) \, dy, \quad (1.2)$$

provided that f is smooth and has its support in the connected component of $\mathbb{R}^n \setminus u(\partial\Omega)$ which contains y_0 . Šverák observed that (1.2) rules out cavitation. For the example $x \rightarrow \frac{x}{|x|} R(|x|)$, $R(0) > 0$, $R'(t) > 0$, which is a map with cavitation it suffices to choose f with support in $B(0, R(0))$. For $u \in A_{p,q}^+(\Omega)$ it allows one to define a set-valued image $F(a, u)$ for every $a \in \Omega$. Moreover, he deduces from (1.2) that functions in $A_{p,q}^+(\Omega)$ are continuous (not just approximately or finely continuous) outside a set of Hausdorff dimension $n-p$. Under additional conditions on the boundary values, he shows the existence of an inverse function defined almost everywhere and analyses its regularity (see also Tang Qi [TQ88]). The condition on q at first glance appears to be natural in view of the identity

$$(\det F) \text{Id} = F(\text{adj } F), \quad (1.3)$$

which by Hölder's inequality gives $\det Du \in L^1$ if $q \geq \frac{p}{p-1}$.

In the current work we generalize the degree formula and all of its consequences to the case $q \geq \frac{n}{n-1}$. Note that one has, by taking determinant in (1.3),

$$|\det F| \leq |\text{adj } F|^{n/(n-1)}, \quad (1.4)$$

so that still $\det Du \in L^1$ in this case. The most important result of this paper is the following *divergence identity*.

THEOREM A. — Let $p \geq n-1$, $q \geq \frac{n}{n-1}$, $u \in A_{p,q}(\Omega)$, $g \in C^1(\mathbb{R}^n; \mathbb{R}^n)$ with $|\text{D}g| \leq C$. Consider the distribution

$$h := \frac{\partial}{\partial x^j} \{ (g^i \circ u) (\text{adj } Du)_i^j \}.$$

Then

$$h = (\text{div } g) \circ u \det Du \quad (1.5)$$

in the sense of distributions (and hence in L^1).

For smooth functions, (1.5) follows from the fact that $\text{adj } Du$ is divergence-free, i. e.

$$\frac{\partial}{\partial x^j} (\text{adj } Du)_i^j = 0 \quad \text{for } i = 1, \dots, n \quad (1.6)$$

(see [Mo66], Lemma 4.4.6; here as in the following we employ the summation convention) in connection with (1.3). If $q \geq \frac{p}{p-1}$, then (1.5) can be established by approximating u by smooth functions $u^{(v)}$ and $\text{adj } Du$ by divergence free $b^{(v)}$. To obtain (1.5) for $q \geq \frac{n}{n-1}$ we exploit the geometric significance of $\text{adj } Du$ and not just (1.6) and make, in particular, use of a suitable version of the isoperimetric inequality (see Lemma 3.1, Theorem 3.2 and their proofs).

In the critical case $q = \frac{n}{n-1}$, one obtains $\det Du \in L^1(\Omega)$ from (1.4) and by scaling arguments one would, in general, expect no better estimate. If $\det Du \geq 0$, one has, however, the following *higher integrability* property which generalizes the results in [Mu89] and [Mu90 b]. Other interesting higher integrability results have recently been obtained by Iwaniec and Sbordone [IS91], Brezis, Fusco and Sbordone [BFS92], Greco and Iwaniec [GI92] and Iwaniec and Lutoborski [IL92].

THEOREM B. — *Let $u \in A_{n-1, n/(n-1)}(\Omega)$ and assume that $\det Du \geq 0$ a.e. Then $\det Du \ln(2 + \det Du) \in L^1_{\text{loc}}(\Omega)$. More precisely if $B(a, 2r) \subset \Omega$, we have*

$$\int_{B(a, r)} \det Du \ln \left(2 + \frac{\det Du}{(\det Du)_B} \right) dx \leq C \int_{B(a, 2r)} |\text{adj } Du|^{n/(n-1)} dx,$$

where

$$(\det Du)_B = \frac{1}{|B(a, r)|} \int_{B(a, r)} \det Du \, dx = \frac{1}{|B(a, r)|} \int_{B(a, r)} \det Du.$$

Coifman, Lions, Meyers and Semmes [CLMS89] showed that if $u \in W^{1, n}(\mathbb{R}^n; \mathbb{R}^n)$ then $\det Du$ lies in the Hardy space $\mathcal{H}^1(\mathbb{R}^n)$. It would be interesting to know if the same conclusion holds when $u \in A_{n-1, n/(n-1)}$.

While we have emphasized motivations from nonlinear elasticity, it should be noted that the study of properties of $W^{1, p}$ maps arises in many other contexts and in particular in the analytic approach to quasiconformal mappings. Of the vast literature, we only mention the survey article by Bojarski and Iwaniec [BI83] and the books by Reshetnyak [Re85] and Rickman [Ri93], where further references can be found.

The remainder of the paper is organised as follows. Section 2 summarizes the notation (which follows [Sv88]) and gives some auxiliary results. Section 3, which is the core of the paper, contains the proofs of Theorems A and B. In section 4 these results are applied to nonlinear elasticity. Focusing on the physically relevant case $n = 3$, we show, in particular, that for a stored energy density of the form (1.1), minimizers

exist if $p \geq 2$, $q \geq \frac{3}{2}$. This improves results of Ball and Murat [BM84], Zhang [Zh90] and [Mu90 b] which all require $q \geq \frac{p}{p-1}$. Finally in section 5 we deduce the degree formula (1.2) from Theorem A. This allows one to generalize Šverák's results to the case $q \geq \frac{n}{n-1}$ and we state some of these explicitly.

2. PRELIMINARIES

Except for Lemma 2.3 and Propositions 2.4 and 2.5, this section is essentially identical to section 2 of [Sv88] although we do not make use of differential forms. We include it here to keep the present exposition self-contained.

We begin by recalling some facts from multilinear algebra (*cf.* Federer [Fe69], Chapter 1 or Flanders [Fl63]). We denote by \cdot the scalar product of vectors in \mathbb{R}^n and by \wedge their exterior product. For $n \geq 2$ we identify the space $\Lambda_{n-1} \mathbb{R}^n$ of $(n-1)$ vectors with \mathbb{R}^n by means of the map $\star : \Lambda_{n-1} \mathbb{R}^n \rightarrow \mathbb{R}^n$.

The map

$$(\xi_1, \dots, \xi_{n-1}) \mapsto \xi_1 \wedge \dots \wedge \xi_{n-1}$$

is characterized by the following conditions:

- (i) It is multilinear and alternating.
- (ii) If e_1, \dots, e_n is the canonical basis of \mathbb{R}^n , then

$$\star(e_1 \wedge \dots \wedge \hat{e}_i \wedge \dots \wedge e_n) = (-1)^{n-i} e_i,$$

where, as usual, the symbol under $\hat{}$ is to be omitted.

If $\xi, \eta \in \mathbb{R}^3$ then $\xi \wedge \eta$ is the usual vector product.

For a linear map $F : \mathbb{R}^n \rightarrow \mathbb{R}^n$, the map $\Lambda_{n-1} F$ is defined by

$$(\Lambda_{n-1} F)(\xi_1 \wedge \dots \wedge \xi_{n-1}) = F \xi_1 \wedge \dots \wedge F \xi_{n-1}$$

and its norm is given by

$$|\Lambda_{n-1} F| = \sup \{ |\Lambda_{n-1} F(\xi_1 \wedge \dots \wedge \xi_{n-1})| : \xi_i \in \mathbb{R}^n \text{ and } |\xi_1 \wedge \dots \wedge \xi_{n-1}| \leq 1 \}.$$

If A is the matrix of F with respect to the canonical basis, given by $F e_i = a_i^j e_j$ (we recall that the summation convention is in force), then the matrix B of $\Lambda_{n-1} F$ is the cofactor matrix of A ,

$$B = (\text{cof } A) = (\text{adj } A)^T = A^{-T} \det A. \tag{2.1}$$

The norm of a matrix A will be identified with that of the linear map that the matrix represents in the canonical basis. Hence for F and A as above, one has

$$|\Lambda_{n-1} F| = |\text{Cof } A| = |\text{adj } A|.$$

If V is an $(n-1)$ dimensional subspace and $F: V \rightarrow \mathbb{R}^n$ is a linear map then $\Lambda_{n-1} F: \Lambda_{n-1} V \rightarrow \mathbb{R}^n$ is defined by

$$(\Lambda_{n-1} F)(\xi_1 \wedge \dots \wedge \xi_{n-1}) = F \xi_1 \wedge \dots \wedge F \xi_{n-1}$$

and its norm is now given by

$$|\Lambda_{n-1} F| = \sup \{ |\Lambda_{n-1} F(\xi_1 \wedge \dots \wedge \xi_{n-1})| : \xi_i \in V, \text{ and } |\xi_1 \wedge \dots \wedge \xi_{n-1}| \leq 1 \}. \quad (2.2)$$

Let v be a unit vector normal to V . Then the one dimensional space $\Lambda_{n-1} V$ may be identified with $\{\lambda v : \lambda \in \mathbb{R}\}$. Let $\tilde{F}: \mathbb{R}^n \rightarrow \mathbb{R}^n$ be a linear extension of F . If A is the matrix of \tilde{F} with respect to the canonical basis and if $v = v^j e_j$, one has

$$(\Lambda_{n-1} F)v = (\text{adj } A)_i^j v^j e_i, \quad (2.3)$$

$$|\Lambda_{n-1} F| = |(\Lambda_{n-1} F)v|. \quad (2.4)$$

In the following, Ω will always denote a nonempty, bounded, open subset of \mathbb{R}^n , $n \geq 2$. By $L^p(\Omega)$ and $W^{1,p}(\Omega)$, we denote the spaces of p -summable and Sobolev functions, respectively. A function is in $L^p_{\text{loc}}(\Omega)$ if $f \in L^p(\Omega')$ for all open sets Ω' compactly contained in Ω . A vector- or matrix-valued function is in L^p (resp. $W^{1,p}$) if all its components are; we use the notation $L^p(\Omega; \mathbb{R}^n)$ etc. By $C^r(\Omega)$ we denote the space of r -times continuously differentiable functions; and $\mathcal{D}(\Omega) = C^\infty_0(\Omega)$ is the space of smooth functions with compact support. Its dual $\mathcal{D}'(\Omega)$ is the space of distributions.

Weak convergence is indicated by the half-narrow \rightharpoonup , weak- \star convergence by \rightharpoonup^\star . By \circ we denote composition of functions, by \star the convolution.

We let

$$B(a, r) = \{x \in \mathbb{R}^n : |x - a| < r\},$$

$$S(a, r) = \{x \in \mathbb{R}^n : |x - a| = r\}, \quad B = B(0, 1).$$

For $a \in \Omega$, we let $r_a = \text{dist}(a, \mathbb{R}^n \setminus \Omega)$. The n -dimensional Lebesgue measure is denoted by L^n , k -dimensional Hausdorff measure by H^k .

We will occasionally consider Sobolev spaces of functions defined on $\partial\Omega$. We say that Ω has Lipschitz boundary (see [Ne67], p. 14) if there exist numbers $\alpha > 0$, $\beta > 0$ and coordinate systems

$$(y_r^1, \dots, y_r^n) = (y'_r, y''_r), \quad r = 1, \dots, M$$

as well as Lipschitz continuous functions

$$a_r : \bar{\Delta}_r = \{|y_r^i| \leq \alpha; i = 1, \dots, n-1\} \rightarrow \mathbb{R}$$

such that each point $x \in \partial\Omega$ can be represented in at least one coordinate system in the form $x = (y'_r, a(y'_r))$. Moreover, one requires that the points (y'_r, y''_r) with $|y'_r| \in \Delta_r$, lie in Ω if $a(y'_r) < y'_r < a(y'_r) + \beta$ and that they lie outside Ω if $a(y'_r) - \beta < y''_r < a(y'_r)$. Morrey ([Mo66], Definition 3.4.1) called such sets strongly Lipschitz.

A function $u : \partial\Omega \rightarrow \mathbb{R}$ is in $W^{1,p}(\partial\Omega)$ [resp. $L^q(\partial\Omega)$] if all the functions $u_r(y'_r) := u((y'_r, a_r(y'_r)))$ (with y_r and a_r as above) are in $W^{1,p}(\Delta_r)$ [resp. $L^q(\Delta_r)$]. We say that $u \in A_{p,q}(\partial\Omega)$ if

$$u \in W^{1,p}(\partial\Omega; \mathbb{R}^n) \quad \text{and} \quad |\Lambda_{n-1} Du| \in L^q(\partial\Omega). \tag{2.5}$$

We will use the fact that $W^{1,p}$ functions have $W^{1,p}$ traces on a.e. sphere. More precisely we let $\rho \in C_0^\infty(\mathbb{B})$, $\rho \geq 0$, $\int_{\mathbb{B}} \rho = 1$, $\rho_\varepsilon(x) = \varepsilon^{-n} \rho\left(\frac{x}{\varepsilon}\right)$ and we have

PROPOSITION 2.1. — *Let $p \geq 1$, $u \in W^{1,p}(\Omega)$, $a \in \Omega$, $r_a = \text{dist}(a, \partial\Omega)$. Then there exists an L^1 null set N_a such that for all $r \in (0, r_a) \setminus N_a$*

$$\rho_\varepsilon * u \rightarrow u|_{S(a,r)} \quad \text{in } W^{1,p}(S(a,r)).$$

Moreover if $u \in A_{p,q}(\Omega)$ with $p \geq 1$, $q \geq 1$, then $u \in A_{p,q}(S(a,r))$ for L^1 a.e. $r \in (0, r_a)$.

Remark. — Here $u|_{S(a,r)}$ is understood in the sense of trace (see e.g. [Ne67], Chapters 2.4 and 2.5).

Proof. — To prove the first assertion, consider polar co-ordinates in $\mathbb{B}\left(a, r_a - \frac{1}{k}\right) \setminus \mathbb{B}\left(a, \frac{1}{k}\right)$ and use Fubini's theorem to find L^1 null sets N_a^k such that the conclusion holds for $r \in \left(\frac{1}{k}, r_a - \frac{1}{k}\right) \setminus N_a^k$. Then let

$N_a = \bigcup_{k=1}^\infty N_a^k$. The proof of the second assertion is similar (see also Morrey

[Mo66], Chapter 3.1 or Nečas [Ne67], Theorem 2.2.2). \square

We briefly recall some facts about the Brouwer degree (see e.g. Schwartz [Sc69] for more details). Let $\Omega \subset \mathbb{R}^n$ be bounded, open and let $u : \bar{\Omega} \rightarrow \mathbb{R}^n$ be a C^∞ map. If $y_0 \in \mathbb{R}^n \setminus u(\partial\Omega)$ is such that $\det Du(x) \neq 0$ for all $x \in u^{-1}(y_0)$, one defines

$$\text{deg}(u, \Omega, y_0) = \sum_{x \in u^{-1}(y_0)} \text{sgn det } Du(x).$$

If f is a C^∞ function supported in the connected component of $\mathbb{R}^n \setminus u(\partial\Omega)$ which contains y_0 , one can show that

$$\int_{\Omega} (f \circ u) \det Du \, dx = \text{deg}(u, \Omega, y_0) \int_{\mathbb{R}^n} f \, dy. \tag{2.6}$$

Using this formula and approximating by C^∞ functions, one can define $\text{deg}(u, \Omega, y)$ for any continuous function $u: \Omega \rightarrow \mathbb{R}^n$ and any $y \in \mathbb{R}^n \setminus u(\partial\Omega)$. Moreover the degree only depends on $u|_{\partial\Omega}$.

Indeed if Ω has Lipschitz boundary and if $u \in C^\infty(\Omega; \mathbb{R}^n)$, then the degree can be expressed as a boundary integral as follows. First recall the identity (see [Mo66], Lemma 4.4.6)

$$\frac{\partial}{\partial x^j} (\text{adj } Du)_i^j = 0 \quad \text{for } i = 1, \dots, n.$$

Let f be as above and let $g: \mathbb{R}^n \rightarrow \mathbb{R}^n$ be C^∞ with $\text{div } g = f$ then the above identity in connection with (1.3) implies that

$$\frac{\partial}{\partial x^j} ((g^i \circ u) (\text{adj } Du)_i^j) = (f \circ u) \det Du.$$

By the Gauss-Green formula (for Lipschitz sets) and (2.3)

$$\int_{\Omega} (f \circ u) \det Du \, dx = \int_{\partial\Omega} (g \circ u) \cdot (\Lambda_{n-1} Du) \nu \, dH^{n-1} \tag{2.7}$$

and by (2.6)

$$\text{deg}(u, \partial\Omega, y_0) \int_{\mathbb{R}^n} f \, dy = \int_{\partial\Omega} (g \circ u) \cdot (\Lambda_{n-1} Du) \nu \, dH^{n-1} \tag{2.8}$$

Here ν denotes the outward normal of $\partial\Omega$ (which exists H^{n-1} a.e.) and Du is viewed as a map from the tangent space of $\partial\Omega$ to \mathbb{R}^n .

LEMMA 2.2 ([Sv88], Lemma 1). — Assume that Ω has Lipschitz boundary and that $p \geq n - 1$. Then (2.8) holds for every

$$u \in W^{1,p}(\partial\Omega; \mathbb{R}^n) \cap C^0(\partial\Omega; \mathbb{R}^n).$$

Proof. — It suffices to show that there exists a sequence $\tilde{u}_k \in C^\infty(\bar{\Omega}; \mathbb{R}^n)$ with $\tilde{u}_k|_{\partial\Omega} \rightarrow u$ uniformly and in $W^{1,p}(\partial\Omega)$. This is clear if Ω has smooth boundary and well-known to experts if Ω has Lipschitz boundary. We include the details for the convenience of the reader.

By a partition of unity (see e.g. [Ne67], p. 27) and a change of coordinates we may assume that there is a Lipschitz function a and constants $\alpha, \beta > 0$ such that

$$\begin{aligned} \text{supp } u &\subset \partial\Omega \cap U, \\ \Omega \cap U &= \{ (x', x_n) : a(x') < x_n < a(x') + \beta, x' \in \Delta \}, \\ \partial\Omega \cap U &= \{ (x', a(x')) : x' \in \Delta \} \end{aligned}$$

where

$$\Delta = (-\alpha, \alpha)^{n-1}, \quad U = \{ (x', x_n) : x' \in \Delta, a(x') - \beta < x_n < a(x') + \beta \}.$$

We may assume $a(0) = 0$ and, by possibly decreasing α , $|a| \leq \beta/4$. Let

$$v(x') = u(x', a(x')).$$

By the definition of $W^{1,p}(\partial\Omega)$, $v \in W^{1,p}(\Delta)$. Moreover $\text{supp } v \subset \Delta$ and $v \in C^0(\Delta)$. Hence there exist $v_k \in C_0^\infty(\Delta)$ which converge to v in $W^{1,p}$ and uniformly. Let $\eta \in C_0^\infty(-\beta/2, \beta/2)$ with $\eta \equiv 1$ on $[-\beta/4, \beta/4]$ and let $\tilde{u}_k(x) = \eta(x_n) v_k(x')$.

Clearly $\tilde{u}_k \in C_0^\infty(\mathbb{R}^n)$ and $u_k(x', a(x')) = v_k(x')$. Hence

$$\tilde{u}_k|_{\partial\Omega} \rightarrow u|_{\partial\Omega} \quad \text{in } W^{1,p}(\partial\Omega) \cap C^0(\partial\Omega),$$

by the definition of convergence in $W^{1,p}(\partial\Omega)$ (see [Ne67], p. 94). The proof is finished. \square

We need the following criterion for weak compactness in L^1 .

LEMMA 2.3 ([MS47], [Me66]). — *Let $E \subset \mathbb{R}^n$ be measurable with finite measure and let $f^{(v)}$ be a sequence in $L^1(E)$. Then $f^{(v)}$ is relatively weakly sequentially compact in $L^1(E)$ if and only if there exists a function $\gamma: \mathbb{R}_0^+ \rightarrow \mathbb{R}_0^+$ with $\lim_{t \rightarrow \infty} \gamma(t)/t = \infty$ such that*

$$\sup_v \int_E \gamma(|f^{(v)}|) dx < \infty.$$

Moreover γ may be chosen as an increasing function. An immediate consequence of the lemma is

PROPOSITION 2.4. — *If $g^{(v)} \rightarrow g$ in $L^1(E)$ and $|f^{(v)}| \leq C|g^{(v)}|$ then $f^{(v)}$ is weakly compact in $L^1(E)$.*

We will use the following version of the chain rule. The result and its proof are well-known to experts. We include the result for the convenience of the reader.

PROPOSITION 2.5. — *Let $\Omega', \Omega \subset \mathbb{R}^n$ be open, let $\varphi: \bar{\Omega}' \rightarrow \bar{\Omega}$ be a bi-Lipschitz homeomorphism. If $u \in W^{1,p}(\Omega)$ then $u \circ \varphi \in W^{1,p}(\Omega')$ and the distributional derivatives satisfy*

$$D(u \circ \varphi) = (Du) \circ \varphi D\varphi. \quad (2.9)$$

Warning. — The chain rule is meaningless if one has no control on φ^{-1} . Consider the following example (pointed out to us by F. Murat).

Let $\varphi: \mathbb{R}^2 \rightarrow \mathbb{R}^2$, $\varphi(x, y) = (x, x)$, $u: \mathbb{R}^2 \rightarrow \mathbb{R}$, $u(x, y) = |x - y|^{-\alpha}$. One has $u \in W^{1,p}(\mathbb{R}^2)$ if $p < \frac{2}{1+\alpha}$ but $u \circ \varphi \equiv +\infty$. If $u(x, y) = |x - y|$, then $u \circ \varphi \equiv 0$ but (2.9) does not make sense as Du is nowhere defined on $\varphi(\mathbb{R}^2)$.

Proof. — See Morrey [Mo66], Theorem 3.1.7. Use e.g. the area formula to pass to the limit in his equation (3.1.6). \square

3. THE DIVERGENCE IDENTITIES

In this section we prove the divergence identities as well as the higher integrability of the Jacobian (Theorems A and B of the Introduction) and deduce an “isoperimetric” inequality (Lemma 3.4). We recall the notation

$$r_a = \text{dist}(a, \partial\Omega).$$

The main tool is

LEMMA 3.1. — *Let $p > n - 1$, $u \in W^{1,p}(\Omega; \mathbb{R}^n)$, $a \in \Omega$. Then there exists an L^1 null set N_a such that for all $r \in (0, r_a) \setminus N_a$ and for all $g \in C^1(\mathbb{R}^n; \mathbb{R}^n)$ with $|\text{D}g| \leq C$ one has*

$$\left| \int_{S(a,r)} (g \circ u) \cdot (\Lambda_{n-1} \text{D}u) \nu \, dH^{n-1} \right| \leq C(n) \|\text{div } g\|_\infty \left\{ \int_{S(a,r)} |\Lambda_{n-1} \text{D}u| \, dH^{n-1} \right\}^{n/n-1}. \quad (3.1)$$

The same estimate holds for $p = n - 1$, provided that g is also bounded.

Remarks. — 1. At $x \in S(a, r)$, $\text{D}u(x)$ is interpreted as a map from the tangent space $T_x S$ to \mathbb{R}^n ; see (2.2) for the definition of $\Lambda_{n-1} \text{D}u$ and recall from (2.3), (2.4) that for smooth u , one has

$$(\Lambda_{n-1} \text{D}u) \nu = (\text{adj } \text{D}u)_i^j \nu_j e_i \quad \text{and} \quad |\Lambda_{n-1} \text{D}u| = |(\Lambda_{n-1} \text{D}u) \nu|.$$

2. If $p = n - 1$ and if g is not bounded, the estimate still holds if the integral on the left hand side is replaced by the dual pairing between $w^{1,n-1}(\partial\Omega; \mathbb{R}^n)$ and its dual (see the remarks after the proof for the details). If, in addition, $|\Lambda_{n-1} \text{D}u| \in L^s(S(a, r))$ for some $s > 1$, then $(g \circ u) (\Lambda_{n-1} \text{D}u) \nu \in L^1(S(a, r))$ and (3.1) holds in the form stated; see the discussion after the proof of the lemma.

Proof. — First assume that $u \in C^\infty(\overline{B(a, r)}; \mathbb{R}^n)$. By (2.7),

$$\int_{S(a,r)} (g \circ u) \cdot (\Lambda_{n-1} \text{D}u) \nu \, dH_{n-1} = \int_{B(a,r)} (\text{div } g) \circ u \det \text{D}u \, dx \quad (3.2)$$

and by the change of variables formula (see e.g. [Sv88])

$$\int_{B(a,r)} (\text{div } g) \circ u \det \text{D}u \, dx = \int_{\mathbb{R}^n} (\text{div } g)(y) \deg(u, B(a, r), y) \, dy. \quad (3.3)$$

Now (see [Mu90 b], equations (3.1) to (3.4)) using the fact that the degree is an integer as well as the Sobolev embedding theorem for BV functions

and taking into account the first remark above, one finds

$$\begin{aligned} \int_{\mathbb{R}^n} |\text{deg}(u, B(a, r), y)| dy &\leq \int_{\mathbb{R}^n} |\text{deg}(u, B(a, r), y)|^{n/(n-1)} dy \\ &\leq C(n) \left\{ \int_{S(a, r)} |\Lambda_{n-1} Du| dH_{n-1} \right\}^{n/(n-1)}. \end{aligned} \tag{3.4}$$

Combining (3.2) to (3.4), the lemma follows for $u \in C^\infty(\Omega; \mathbb{R}^n)$ (with $N_a = \emptyset$).

Now let $u \in W^{1,p}(\Omega; \mathbb{R}^n)$, $R < r_a$. By virtue of Proposition 2.1, there exists an L^1 null set N and a sequence $u^{(k)} \in C^\infty(B(a, R); \mathbb{R}^n)$ such that for $r \in (0, R) \setminus N$, one has

$$u^{(k)} \rightarrow u \text{ in } W^{1,p}(S(a, r); \mathbb{R}^n).$$

It follows from (2.2) that

$$(\Lambda_{n-1} Du^{(k)}) v \rightarrow (\Lambda_{n-1} Du) v \text{ in } L^{p/(n-1)}(S(a, r); \mathbb{R}^n).$$

In view of (2.4), one easily passes to the limit on the right hand side of (3.1). If $p > n - 1$, by the Sobolev embedding theorem, $u^{(k)} \rightarrow u$ in $L^\infty(S(a, r); \mathbb{R}^n)$ which allows one to pass to the limit on the left hand side of (3.1). Similarly if g is bounded, one has (for a subsequence) $g \circ u^{(k)} \rightarrow g \circ u$ H^{n-1} a.e. and $|g \circ u^{(k)}| \leq C_1$ so that one may pass to the limit using Egoroff's theorem and the equi-integrability of L^1 functions.

Further remarks on $p = n - 1$. — If g is unbounded then in general one does not have $(g \circ u) \cdot (\Lambda_{n-1} Du) v \in L^1(S(a, r))$ so that the integral on the left hand side of (3.1) does not make sense. It can, however, be reinterpreted as a duality pairing by viewing $(\Lambda_{n-1} Du) v$ as a distribution. We only sketch the idea. Let $\Omega = B(a, r)$ and consider the functional

$$J_u(\varphi) := \int_{\Omega} (\text{adj } Du)_i^j \frac{\partial}{\partial x^j} \varphi^i dx.$$

Using the fact that $\frac{\partial}{\partial x^j} (\text{adj } Du)_i^j = 0$ in $\mathcal{D}'(\Omega)$ [which follows from (1.6) by approximation], one shows that $J_u(\varphi)$ only depends on the trace $\varphi|_{\partial\Omega}$. Recall that there is a bounded extension operator

$$E: W^{1, n-1}(\partial\Omega) \rightarrow W^{1, n}(\Omega).$$

Indeed it suffices to apply the Sobolev embedding theorem

$$W^{1, n-1}(\partial\Omega) \rightarrow W^{1-1/n, n}(\partial\Omega)$$

(use the fact that the $W^{s,p}$ norm is defined via local charts, [Ne67], p. 94 and [Ad75], Theorem 7.5.8(ii)) and then the inverse trace theorem (see [Ne67], Theorem 2.5.7).

Using E one sees that $J_u \in (W^{1,n-1}(\partial\Omega; \mathbb{R}^n))'$. Moreover for smooth u , one easily verifies that $J_u = (\Lambda_{n-1} Du) \nu$. Using the density of smooth functions and the above extension operator, one deduces that $u \rightarrow J_u$ is a continuous operator from $W^{1,n-1}(\partial\Omega; \mathbb{R})$ to its dual.

Thus with $u^{(k)}$ as in the proof of the lemma, one has

$$(\Lambda_{n-1} Du^{(k)}) \nu \rightarrow (\Lambda_{n-1} Du) \nu \quad \text{in } (W^{1,n-1}(\partial\Omega; \mathbb{R}^n))'$$

while by the chain rule for Sobolev functions (see [GT83], Lemma 7.5)

$$g \circ u^{(k)} \rightarrow g \circ u \quad \text{in } W^{1,n-1}(\partial\Omega; \mathbb{R}^n).$$

Hence (3.1) holds if the integral on the left is replaced by the duality pairing $\langle g \circ u, (\Lambda_{n-1} Du) \nu \rangle$. Finally if $(\Lambda_{n-1} Du) \nu \in L^s(\partial\Omega)$ for some $s > 1$, one has $(g \circ u) \cdot (\Lambda_{n-1} Du) \nu \in L^1(\partial\Omega)$ and the duality pairing can be expressed as integral. Indeed it suffices to approximate $(\Lambda_{n-1} Du) \nu$ in $L^s \cap (W^{1,n-1})'$ by smooth functions and to observe that by the Sobolev embedding theorem $g \circ u \in L^q(\partial\Omega; \mathbb{R}^n)$ for all $q < \infty$.

The main result of this section is

THEOREM 3.2 (divergence identities). — *Let $p \geq n-1$, $q \geq \frac{n}{n-1}$, $u \in A_{p,q}(\Omega)$, $g \in C^1(\mathbb{R}^n; \mathbb{R}^n)$ with $|Dg| \leq C$. Consider the distribution*

$$h := \frac{\partial}{\partial x^j} \{ (g^i \circ u) (\text{adj } Du)_i^j \}. \tag{3.5}$$

Then $h \in L^1_{\text{loc}}(\Omega)$ and $h = (\text{div } g) \circ u \det Du$ a.e.

Remarks. — 1. For $q \geq \frac{p}{p-1}$, the result is well-known (see [Sv88]); it suffices to approximate u by smooth functions and $(\text{adj } Du)_i^j$ by divergence free vector fields.

2. Note that in view of the inequality (1.4) *a posteriori*, one has $f \in L^s(\Omega)$, $s = \frac{q(n-1)}{n}$.

3. The result is very close to being optimal. The standard counter example is obtained by letting Ω be the unit ball in \mathbb{R}^n , $u(x) = \frac{x}{|x|}$, $g(y) = \frac{1}{n}y$. Then $u \in W^{1,p}(\Omega)$, $\forall p < n$, $\det Du = 0$ a.e. but $f = |\Omega| \delta_0$.

4. The improvement from $q \geq \frac{p}{p-1}$ to $q \geq \frac{n}{n-1}$ uses the special structure of $\text{adj } Du$, not just the fact that $\frac{\partial}{\partial x^j} (\text{adj } Du)_i^j = 0$. Indeed for every $p \in [n-1, n)$ there exist $v \in W^{1,p}(\Omega)$ and $\sigma \in L^q(\mathbb{R}^n, \mathbb{R}^n)$, for all $q < \frac{p}{p-1}$, with $\text{div } \sigma = 0$ in \mathcal{D}' such that $\nabla v \cdot \sigma = 0$ a.e. while $\text{div } v \sigma \neq 0$ in \mathcal{D}' (see [Mu91 b], Corollary 6.2).

Proof. – Note that $g \circ u \in W^{1,p}(\Omega; \mathbb{R}^n)$ and that

$$\frac{1}{p} + \frac{1}{q} \leq \frac{1}{n-1} + \frac{n-1}{n} < 1 + \frac{1}{n}.$$

Hence by the Sobolev embedding theorem $(g^i \circ u) (\text{adj } Du)_i^j \in L^1_{\text{loc}}(\Omega)$ and h is well-defined as a distribution. Moreover by [Mu90 a], it suffices to show that $h \in L^1_{\text{loc}}(\Omega)$.

To this end, consider a radial mollifier

$$\rho(x) = \psi(|x|), \quad \rho \in C^\infty_0(B(0, 1)), \quad \int_{\mathbb{R}^n} \rho \, dx = 1.$$

Let $\rho_\varepsilon(x) = \varepsilon^{-n} \rho\left(\frac{x}{\varepsilon}\right)$, fix $\Omega' \subset \subset \Omega$. We will show that $h \in L^1(\Omega')$. The distribution $\rho_\varepsilon \star h$ is defined by

$$\langle \rho_\varepsilon \star h, \psi \rangle = \langle h, \rho_\varepsilon \star \psi \rangle.$$

For sufficiently small ε , one has $\rho_\varepsilon \star h \in \mathcal{D}'(\Omega')$. In fact $\rho_\varepsilon \star h \in C^\infty(\bar{\Omega}')$. Moreover $\rho_\varepsilon \star h \rightarrow h$ in $\mathcal{D}'(\Omega')$. It thus suffices to show that the convergence occurs weakly in $L^1(\Omega')$. Let $\varepsilon < \frac{1}{2} \text{dist}(\Omega', \partial\Omega)$, and $a \in \Omega'$. Then

$$\begin{aligned} (\rho_\varepsilon \star h)(a) &= - \int_{\mathbb{R}^n} (g^i \circ u)(x) (\text{adj } Du)_i^j(x) \left(\frac{\partial}{\partial x^j} \rho_\varepsilon \right)(x-a) \, dx \\ &= - \int_{\mathbb{R}^n} (g^i \circ u)(x) (\text{adj } Du)_i^j(x) \varepsilon^{-(n+1)} \psi' \left(\frac{|x-a|}{\varepsilon} \right) \frac{x_j - a_j}{|x-a|} \, dx \\ &= - \varepsilon^{-(n+1)} \int_0^\varepsilon \left\{ \int_{S(a,r)} (g \circ u) \cdot (\Lambda_{n-1} Du) \nu \, dH_{n-1} \right\} \psi' \left(\frac{r}{\varepsilon} \right) \, dr. \end{aligned}$$

Thus by Lemma 3.1 and Hölder’s inequality

$$\begin{aligned}
 (\rho_\varepsilon \star h)(a) &\leq C \varepsilon^{-(n+1)} \int_0^\varepsilon \left\{ \int_{S(a,r)} |\Lambda_{n-1} Du| dH_{n-1} \right\}^{n/(n-1)} dr \\
 &\leq C \varepsilon^{-(n+1)} \int_0^\varepsilon \left\{ \int_{S(a,r)} |\Lambda_{n-1} Du|^{n/(n-1)} dH_{n-1} \right\} r dr \\
 &\leq C \varepsilon^{-n} \int_{B(a,\varepsilon)} |\text{adj } Du|^{n/(n-1)} dx.
 \end{aligned}$$

Note that $B(a, \varepsilon) \subset \Omega$ since $\varepsilon < \frac{1}{2} \text{dist}(\Omega', \partial\Omega)$. Let $w = |\text{adj } Du|^{n/(n-1)}$; we may assume without loss of generality that

$$\rho|_{B(0, 1/2)} \geq |B(0, 1)|^{-1}$$

and deduce

$$|\rho_\varepsilon \star h| \leq C |\rho_{2\varepsilon} \star w| \quad \text{in } \Omega'.$$

Choose $\varepsilon_v \rightarrow 0$. As $\rho_{2\varepsilon_v} \star w \rightarrow w$ in $L^1(\Omega')$, Proposition 2.4 implies that $\rho_{\varepsilon_v} \star h$ is weakly compact in $L^1(\Omega')$ and hence $\rho_{\varepsilon_v} \star h \rightharpoonup h$ in $L^1(\Omega')$, since convergence in $\mathcal{D}'(\Omega)$ is already known. In particular, $h \in L^1(\Omega')$ and the proof is finished. \square

In the critical case $q = \frac{n}{n-1}$ it follows from the inequality

$$|\det F| \leq |\text{adj } F|^{n/(n-1)}$$

that $\det Du \in L^1(\Omega)$. From scaling arguments one would think that this is optimal. Under the assumption $\det Du \geq 0$, however, one has the following higher integrability result which generalises the results in [Mu90a], [Mu90b] (see also Iwaniec and Sbordone [IS91], Brezis, Fusco and Sbordone [BFS92], Greco and Iwaniec [GI92] and Iwaniec and Lutoborski [IL92])

THEOREM 3.3. — *Let $u \in A_{n-1, n/(n-1)}(\Omega)$ and assume that $\det Du \geq 0$ a.e., then $\det Du \ln(2 + \det Du) \in L^1_{\text{loc}}(\Omega)$. More precisely, if $B(a, 2r) \subset \Omega$ then*

$$\int_{B(a,r)} \det Du \ln \left(2 + \frac{\det Du}{(\det Du)_B} \right) dx \leq C \int_{B(a,2r)} |\text{adj } Du|^{n/(n-1)} dx,$$

where

$$(\det Du)_B = \int_{B(a,r)} \det Du \, dx = \frac{1}{|B(a,r)|} \int_{B(a,r)} \det Du.$$

Coifman, Lions, Meyer and Semmes [CLMS89] showed that if $u \in W^{1,n}(\mathbb{R}^n; \mathbb{R}^n)$ then $\det Du$ lies in the Hardy space $\mathcal{H}^1(\mathbb{R}^n)$. Since a non negative f is (locally) in \mathcal{H}^1 if and only if $f \log(2+f)$ is in L^1_{loc} , it seems natural to ask whether $u \in A_{n-1, n/(n-1)}(\mathbb{R}^n)$ implies that $\det Du \in \mathcal{H}^1(\mathbb{R}^n)$. We do not know whether this is true or not.

Proof. — The result follows from Theorem 6.2 in [Mu90b] since Theorem 3.2 above implies condition (6.1) of that paper. For the convenience of reader we sketch the proof. We recall that for a function $f \in L^1(\mathbb{R}^n)$ the maximal function Mf is defined by

$$Mf(x) := \sup_{R > 0} \int_{B(x,R)} |f| dy,$$

If f is supported in $B = B(a, R)$ and Mf is integrable over $B(a, r)$, then by a result of E. Stein [St.69]

$$\int_B |f| \log \left(2 + \frac{|f|}{\int_B |f|} \right) dy \leq \int_B Mf dy. \tag{3.6}$$

Now consider a ball $B = B(a, R)$ such that $B(a, 2R) \subset \Omega$ and let

$$f = \chi_{B(a, R)} \det Du.$$

We need to estimate Mf . Fix $x \in B(a, R)$, let $\rho < R/2$. By the isoperimetric inequality (see Lemma 3.4 below) and the positivity of $\det Du$ we have for a.e. $r \in (\rho, 2\rho)$

$$\left\{ \int_{B(x, \rho)} \det Du dy \right\}^{(n-1)/n} \leq \left\{ \int_{B(x, r)} \det Du dy \right\}^{(n-1)/n} \leq C \int_{S(x, r)} |\text{adj } Du| dy.$$

Integrate from ρ to 2ρ and divide by ρ^{n-1} to get

$$\left\{ \int_{B(x, \rho)} \det Du dy \right\} \leq C \left\{ \int_{B(x, 2\rho)} |\text{adj } Du| dy \right\}^{n/(n-1)}.$$

Let

$$g = \chi_{B(a, 2R)} |\text{adj } Du|.$$

It follows that

$$\begin{aligned} Mf(x) &\leq C [Mg(x)]^{n/(n-1)} + \sup_{\rho > R/2} \int_{B(x, \rho)} f dy \\ &\leq C [Mg(x)]^{n/(n-1)} + CR^{-n} \int_{B(a, R)} \det Du dy. \end{aligned}$$

Now by assumption $g \in L^{n/(n-1)}(\mathbb{R}^n)$ and hence (see e.g. [St70]),

$$\|Mg\|_{n/(n-1)} \leq C \|g\|_{n/(n-1)}.$$

Taking into account of (1.4), we deduce

$$\int_{B(a, R)} Mf dx \leq C \int_{B(a, 2R)} |\text{adj } Du|^{n/(n-1)} dx.$$

In view of (3.6) the proof is finished. \square

LEMMA 3.4. — Let $p \geq n - 1$, $q \geq \frac{n}{n-1}$, $u \in A_{p,q}(\Omega)$. Let $a \in \Omega$, for L^1 a.e. $r \in (0, r_a)$ one has

$$\left\{ \left| \int_{B(a,r)} \det Du \, dx \right| \right\}^{(n-1)/n} \leq C \int_{S(a,r)} |\Lambda_{n-1} Du| \, dH^{n-1} \leq C \int_{S(a,r)} |\text{adj } Du| \, dH^{n-1}.$$

Proof. — This follows from Lemma 6.1 in [Mu90 b] and Theorem 3.2 above. To keep the current exposition self-contained, we sketch the proof. Fix $a \in \Omega$. We first claim that Theorem 3.2 implies that for all $v \in C_0^1(\mathbb{R}^n, \mathbb{R}^n)$ and a.e. $r \in (0, r_a)$

$$\int_{B(a,r)} (\text{div } v)(u(x)) \det Du(x) \, dx = \int_{S(a,r)} (v \circ u) \cdot (\Lambda_{n-1} Du) \, v \, dH^{n-1} \quad (3.7)$$

Indeed by Theorem 3.2, one has for all $\psi \in C_0^\infty(\Omega)$

$$\int_{\Omega} \psi (\text{div } v)(u(x)) \det Du(x) \, dx = - \int_{\Omega} (v^i \circ u) (\text{adj } Du)_i^j \frac{\partial}{\partial x_j} \psi \, dx,$$

and choosing test functions $\psi^{(j)}(x) = \tilde{\psi}^{(j)}(|x-a|)$ which approximate $\chi_{B(a,r)}$, one easily shows (3.7) (see [Mu90 b], p. 30 for the details).

Secondly, we claim that there exists an integer-valued function d such that for every continuous $g : \mathbb{R}^n \rightarrow \mathbb{R}$, one has

$$\int_{B(a,r)} g(u(x)) \det Du(x) \, dx = \int_{\mathbb{R}^n} g(y) d(y) \, dy. \quad (3.8)$$

To see this, observe that u is approximately differentiable on $\Omega \setminus E$, with $L^n(E) = 0$ (see [Mo66], Lemma 3.1.1 and [Fe69], 3.1.4) and hence by the area formula (see [Fe69], 3.25, 3.2.20 or [Sv88], Theorem 2) one has for every measurable set $A \subset \Omega \setminus E$

$$\int_A g(u(x)) |\det Du(x)| \, dx = \int_{\mathbb{R}^n} g(y) N(u, A, y) \, dy, \quad (3.9)$$

where $N(u, A, y)$ denotes the number of elements in the set $\{x \in A : u(x) = y\}$. Let

$$A^\pm = \{x \in B(a, r) : \pm \det Du(x) > 0\}$$

and

$$d(y) = N(u, A^+, y) - N(u, A^-, y).$$

Application of (3.9) to A^+ and A^- yields (3.8).

Now let r be such that (3.7) holds. Combining this with (3.8), we deduce that for all $v \in C_0^1(\mathbb{R}^n, \mathbb{R}^n)$

$$\left| \int_{\mathbb{R}^n} (\operatorname{div} v)(y) d(y) dy \right| \leq \|v\|_{C^0} \int_{S(a,r)} |\Lambda_{n-1} Du| dH^{n-1}.$$

Hence d is of bounded variation and the Sobolev embedding (see e.g. [Gi84], Theorem 1.2.3) yields

$$\|d\|_{L^{n/(n-1)}} \leq C \|Dd\|_{\mathcal{M}} \leq C \int_{S(a,r)} |\Lambda_{n-1} Du| dH^{n-1}.$$

Finally, apply (3.8) with $g \equiv 1$ and use the fact that d is integer valued to deduce

$$\begin{aligned} \left| \int_{B(a,r)} \det Du dx \right| &= \left| \int_{\mathbb{R}^n} d dy \right| \leq \int_{\mathbb{R}^n} |d|^{n/(n-1)} dy \\ &\leq C \left\{ \int_{S(a,r)} |\Lambda_{n-1} Du| dH^{n-1} \right\}^{n/(n-1)}. \quad \square \end{aligned}$$

4. APPLICATIONS TO NONLINEAR ELASTICITY

In this section, we establish existence of minimizers in nonlinear elasticity under weakened coercivity conditions on the integrand. We begin with the following weak continuity result.

LEMMA 4.1. — Let $p \geq n-1$, $q > \frac{n}{n-1}$ and let $u^{(v)}$ be a sequence in $A_{p,q}(\Omega)$ satisfying

$$\begin{aligned} u^{(v)} &\rightharpoonup u \text{ in } W^{1,p}(\Omega; \mathbb{R}^n), \\ \operatorname{adj} Du^{(v)} &\text{ bounded in } L^q(\Omega; \mathbb{R}^{n \times n}). \end{aligned}$$

Then

$$\operatorname{adj} Du^{(v)} \rightharpoonup \operatorname{adj} Du \text{ in } L^q(\Omega; \mathbb{R}^{n \times n}), \tag{4.1}$$

$$\det Du^{(v)} \rightharpoonup \det Du \text{ in } L^s(\Omega), \quad s = \frac{q(n-1)}{n} \tag{4.2}$$

If $q = \frac{n}{n-1}$ and if $\det Du^{(v)} \geq 0$ a.e., then instead of (4.2), one has

$$\det Du^{(v)} \rightharpoonup \det Du \text{ in } L^1(K),$$

for all compact sets $K \subset \Omega$.

Proof. — Since $p \geq n-1$ one has (see Ball [Ba77], Dacorogna [Da89], Chapter 4, Theorem 2.6)

$$\operatorname{adj} Du^{(v)} \rightharpoonup \operatorname{adj} Du \text{ in } \mathcal{D}'(\Omega).$$

By hypothesis $\text{adj } Du^{(v)}$ is also bounded in L^q , $q > 1$. Hence the convergence is weakly in L^q . To prove (4.2), consider the distribution

$$\text{Det } Du^{(v)} := \frac{1}{n} \frac{\partial}{\partial x^j} [(u^{(v)})^i (\text{adj } Du^{(v)})^j_i].$$

Since $\frac{1}{p} + \frac{1}{q} \leq \frac{1}{n-1} + \frac{n-1}{n} < 1 + \frac{1}{n}$, $\text{Det } Du^{(v)}$ is well-defined by the Sobolev embedding theorem and using the compactness of the embedding and (4.1) one sees that

$$\text{Det } Du^{(v)} \rightharpoonup \text{Det } Du \quad \text{in } \mathcal{D}'(\Omega).$$

Now apply Theorem 3.2 with $g(y) = \frac{1}{n}y$ to deduce that

$$\det Du^{(v)} = \text{Det } Du^{(v)} \quad \text{and} \quad \text{Det } Du = \det Du.$$

If $q > \frac{n}{n-1}$, then $\det Du$ is bounded in $L^s(\Omega)$ ($s > 1$) by (1.4); assertion (4.2) follows. If $q = \frac{n}{n-1}$ and $\det Du^{(v)} \geq 0$ a.e., the assertion follows by applying Theorem 3.3 in connection with Lemma 2.3. \square

Consider now an elastic body which occupies an open, bounded set $\Omega \subset \mathbb{R}^3$ (with Lipschitz boundary) in a reference configuration. Let $\partial\Omega_1$ be a subset of $\partial\Omega$ with positive two-dimensional measure. We assume that the deformation $u: \Omega \rightarrow \mathbb{R}^3$ is prescribed on $\partial\Omega_1$ while $\partial\Omega_2 = \partial\Omega \setminus \partial\Omega_1$ is traction free. We seek to minimize the elastic energy

$$I(u) = \int_{\Omega} W(x, u, Du) \, dx$$

in the function class

$$\mathcal{A} = \{ u \in W^{1,1}(\Omega; \mathbb{R}^3) : u = \bar{u} \text{ on } \partial\Omega_1, I(u) < \infty \}.$$

We allow W to take the value $+\infty$ to incorporate the constraint $\det Du > 0$ which corresponds to the fact that the deformation is (locally) orientation preserving.

THEOREM 4.2. — *Assume that*

(i) *(polyconvexity)*

$$W(x, u, F) = g(x, u, F, \text{adj } F, \det F),$$

where $g(x, u, \cdot)$ is convex;

(ii) *(continuity)* $g(x, \cdot, \cdot)$ is continuous (as a function with values in $\mathbb{R} = \mathbb{R} \cup \{+\infty\}$), $g(\cdot, u, F, \text{adj } F, \det F)$ is measurable;

(iii) $W(x, u, F) = +\infty$ if and only if $\det F \leq 0$;

(iv) (coercivity)

$$W(x, u, F) \geq a(|F|^p + |\operatorname{adj} F|^q),$$

where $a > 0$, $p \geq 2$, $q \geq \frac{3}{2}$. Assume furthermore that $\mathcal{A} \neq \emptyset$. Then I attains its minimum on \mathcal{A} .

Proof. — Applying Lemma 4.1 to a minimizing sequence, this is by now standard (see [Ba77] or [Mu90b], Theorem 6.2). \square

The theorem improves results of Ball and Murat [BM84], Zhang [Zh90] and [Mu90b] which all require $q \geq \frac{p}{p-1}$. Non-zero dead load traction conditions and other modification can be incorporated in the standard way (see [Ba77]).

5. REGULARITY AND INVERTIBILITY PROPERTIES

We use the divergence identities in Theorem 3.2 to generalise Šverák's degree formula to the class $A_{p,q}(\Omega)$, $p > n - 1$, $q \geq \frac{n}{n-1}$. Once this is done his results and proofs apply *verbatim* to our larger class. Here we only spell out some of these explicitly and refer the reader to [Sv88] for the details. Recall the definition of $A_{p,q}(\partial\Omega)$ from (2.5).

THEOREM 5.1 (degree formula). — *Let $\Omega \subset \mathbb{R}^n$ be a bounded, open set with Lipschitz boundary, let $p \geq n - 1$, $q \geq \frac{n}{n-1}$. Assume that $u \in A_{p,q}(\Omega)$ and that its trace belongs to $A_{p,q}(\partial\Omega)$ and has a continuous representative \bar{u} . Let $y_0 \in \mathbb{R}^n \setminus \bar{u}(\partial\Omega)$ and let f be a bounded and smooth function supported in the component of $\mathbb{R}^n \setminus \bar{u}(\partial\Omega)$ which contains y_0 . Then*

$$\int_{\Omega} (f \circ u) \det Du \, dx = \deg(u, \partial\Omega, y_0) \int_{\mathbb{R}^n} f \, dy. \quad (5.1)$$

Remarks. — 1. If $p > n - 1$ then the trace has a continuous representative by the Sobolev embedding theorem.

2. For the results discussed below it suffices to have the degree formula (5.1) for smooth domains. We stated the more general version with future applications in mind.

We postpone the proof of the theorem until the end of this section and first discuss some of its consequences. From now on, we assume that

$p > n - 1$, $q \geq \frac{n}{n-1}$. Šverák observed that if one considers functions in

$$A_{p,q}^+(\Omega) = \{ u \in A_{p,q}(\Omega) : \det Du > 0 \text{ a.e.} \},$$

then one can define a set-valued image $F(a, u)$ for every point $a \in \Omega$. Indeed by Proposition 2.1 there is an L^1 null set N_a such that for all $r \in (0, r_a) \setminus N_a$ [where $r_a = \text{dist}(a, \partial\Omega)$] one has $u \in A_{p,q}(\partial B(a, r))$. Let \tilde{u} be the continuous representative of the trace (recall $p > n - 1$) and let

$$E(u, B(a, r)) = \{ y \in \mathbb{R}^n \setminus u(\partial B(a, r)) : \deg(u, \partial B(a, r), y) \geq 1 \} \cup u(\partial B(a, r)).$$

Using (5.1), one verifies that

$$E(u, B(a, r)) \subset E(u, B(a, s))$$

if $r, s \in (0, r_a) \setminus N_a$, $r < s$ (see [Sv88], Lemma 3) and one defines

$$F(a, u) = \bigcap_{r \in (0, r_a) \setminus N_a} E(u, B(a, r)),$$

$$F(A) = \bigcup \{ F(x) : x \in A \}, \quad \text{if } A \subset \Omega.$$

One has the following regularity results which are proved exactly as in [Sv88]. Similar results have recently been obtained by Manfredi [Ma92] using a different techniques. For $p = n$, the result was already proved by Vodopyanov and Goldstein [VG77].

THEOREM 5.2 (cf. [Sv88], Theorem 4). — *If $u \in A_{p,q}^+(\Omega)$ with $p > n - 1$, $q \geq \frac{n}{n-1}$, then u has a representative \tilde{u} which is continuous outside a set S of Hausdorff dimension $n - p$. Moreover, for each $\varepsilon > 0$, the set $\{ x \in \Omega, \limsup_{r \rightarrow 0^+} \text{osc}(\tilde{u}, B(x, r)) < \varepsilon \}$ is open.*

THEOREM 5.3 (cf. [Sv88], Theorem 6). — *Let $u \in A_{p,q}^+(\Omega)$ with $p > n - 1$, $q \geq \frac{n}{n-1}$ and let F be the set function defined above. Then*

- (i) $\mathcal{H}^{n-1}(F(a)) = 0$ for each $a \in \Omega$.
- (ii) For each measurable set $A \subset \Omega$, the set $F(A)$ is measurable and

$$L^n(F(A)) \leq \int_A \det Du \, dx.$$

In particular $L^n(F(S)) = 0$ where S is the singular set in Theorem 5.2.

Similarly Šverák’s results on the existence and regularity of an inverse function can be generalized to the case $q \geq \frac{n}{n-1}$ (instead of $q \geq \frac{p}{p-1}$).

For detailed statements we refer the reader to section 5 of [Sv88], and in particular to Theorems 7 and 8. Also in the results of Tang Qi [TQ88] on

almost everywhere injectivity (which generalize earlier work of Ciarlet and Nečas [CN87]) one may now replace the condition $q \geq \frac{p}{p-1}$ by $q \geq \frac{n}{n-1}$.

Proof of Theorem 5.1. – We follow essentially Šverák’s proof but use Theorem 3.2 to weaken the hypothesis on q . Assume first that $f \in C_0^\infty(\mathbb{R}^n)$. This is no restriction of generality as long as $\text{deg}(\bar{u}, \Omega, y_0) \neq 0$. Indeed $\mathbb{R}^n \setminus \bar{u}(\partial\Omega)$ contains only one unbounded component [since $\bar{u}(\partial\Omega)$ is compact] and the degree vanishes on that component (see [Sc69]). There exists $g \in C^\infty(\mathbb{R}^n; \mathbb{R}^n)$ satisfying

$$\begin{aligned} \text{div } g &= f \\ |g|(x) + |Dg(x)| &\rightarrow 0 \text{ as } |x| \rightarrow \infty, \end{aligned}$$

take e.g. $g_i = K_i \star f$, $K_i(z) = \frac{c_n z_i}{|z|^{n+2}}$.

By Lemma 2.2 we have

$$\text{deg}(\bar{u}, \partial\Omega, y_0) \int_{\mathbb{R}^n} f dy = \int_{\partial\Omega} (g \circ u) \cdot (\Lambda_{n-1} D\bar{u}) \nu dH_{n-1}.$$

We claim that for all $\psi \in C_0^\infty(\mathbb{R}^n)$,

$$\begin{aligned} \int_{\partial\Omega} \psi(g \circ u) \cdot (\Lambda_{n-1} Du) \nu dH_{n-1} \\ = \int_{\Omega} \left\{ \left(\frac{\partial}{\partial x^j} \psi \right) (g \circ u) (\text{adj } Du)_i + \psi(f \circ u) \det Du \right\} dx. \end{aligned} \quad (5.2)$$

Taking into account of Lemma 2.2, the theorem follows by applying (5.2) to a ψ with $\psi|_{\bar{\Omega}} \equiv 1$. By a partition of unity it suffices to consider two cases. Either ψ is supported in a neighbourhood of the boundary represented by a Lipschitz chart (cf. the definition of sets with Lipschitz boundary in section 2) or $\psi \in C_0^\infty(\Omega)$. The latter case is the content of Theorem 3.2. To deal with the former, we follow Šverák’s idea to extend u outside Ω . To obtain the result for Lipschitz boundaries, we first have to “flatten” the boundary.

After changing coordinates it suffices to consider the following situation. Let $x = (x', x^n)$, $\Delta = (-\alpha, \alpha)^{n-1}$, let $a: \Delta \rightarrow \mathbb{R}$ be Lipschitz and consider

$$\Omega' = \{x \in \Delta \times \mathbb{R} : x_n > a(x')\}, \quad \Gamma' = \{x \in \Delta \times \mathbb{R} : x_n = a(x')\}.$$

Assume that $u \in A_{p,q}(\Omega')$ and that $\bar{u} = u|_{\Gamma'}$ belongs to $A_{p,q}(\Gamma')$. Let $\psi \in C_0^\infty(\Delta \times \mathbb{R})$. We have to show that

$$\begin{aligned} \int_{\Gamma'} \psi(g \circ \bar{u}) \cdot (\Lambda_{n-1} D\bar{u}) \nu dH_{n-1} \\ = \int_{\Omega'} \left\{ \left(\frac{\partial}{\partial x^j} \psi \right) (g^j \circ u) (\text{adj } Du)_i^j + \psi(f \circ u) \det Du \right\} dx. \end{aligned} \quad (5.3)$$

To transform the problem to a region with a flat boundary, consider

$$\Phi(y', y^n) = (y', a(y') + y^n).$$

Note that Φ is a bi-Lipschitz map of $\Delta \times \mathbb{R}$ to itself. Let

$$v = u \circ \Phi, \quad \bar{v} = \bar{u} \circ \Phi|_{\Delta}, \quad \eta = \psi \circ \Phi.$$

Using the chain rule (here we use the fact that Φ has a Lipschitz inverse, see Proposition 2.5) and the identity $\text{adj}(AB) = (\text{adj } B)(\text{adj } A)$, one easily verifies that

$$v \in A_{p,q}(\Delta \times \mathbb{R}_+), \quad \bar{v} \in A_{p,q}(\Delta).$$

Moreover,

$$\det Dv = (\det Du) \circ \Phi \det D\Phi,$$

and

$$\begin{aligned} (\text{adj } Dv)_i^j \left(\frac{\partial}{\partial y^j} \eta \right) &= (\text{adj } D\Phi)_k^j (\text{adj } Du)_i^k \circ \Phi \left(\frac{\partial}{\partial x^l} \psi \right) \circ \Phi (D\Phi)_j^l \\ &= \left[(\text{adj } Du)_i^l \frac{\partial}{\partial x^l} \psi \right] \circ \Phi \det D\Phi. \end{aligned}$$

Hence by the area formula (see [Fe69], Theorem 3.2.5; [Si83], 8.4 or [EG91], Section 3.3), the right-hand side of (5.3) is equal to

$$\int_{\Delta \times \mathbb{R}_+} \left\{ \left(\frac{\partial}{\partial y^j} \eta \right) (g^i \circ v) (\text{adj } Dv)_i^j + \eta (f \circ v) \det Dv \right\} dy. \quad (5.4)$$

Let ν be the outer unit normal of Γ' . Taking into account that

$$\begin{aligned} (\Lambda_{n-1} D\bar{v}) e_n &= [\Lambda_{n-1} (D\bar{u} \circ \Phi D\Phi|_{\Delta}) e_n] = (\Lambda_{n-1} D\bar{u}) \circ \Phi [(\Lambda_{n-1} D\Phi|_{\Delta}) e_n] \\ &= -(\Lambda_{n-1} D\bar{u}) \circ \Phi (1 + |Da|^2)^{1/2} \nu \end{aligned}$$

and observing that $(1 + |Da|^2)^{1/2}$ is the area element of Γ' , one finds, by another application of the area formula,

$$\int_{\Gamma'} \psi(g \circ \bar{u}) \cdot (\Lambda_{n-1} D\bar{u}) \nu dH_{n-1} = - \int_{\Delta} \eta(g \circ \bar{v}) \cdot \Lambda_{n-1} (D\bar{v}) e_n dx'. \quad (5.5)$$

It only remains to show that the right-hand side of (5.5) equals (5.4). To this end extend v to $\Delta \times \mathbb{R}$ by letting

$$v(y', y^n) = \bar{v}(y') \quad \text{if } y^n < 0.$$

Clearly $v \in W_{\text{loc}}^{1,p}(\Delta \times \mathbb{R})$ since $\bar{v} \in W^{1,p}(\Delta)$. Moreover using (2.3) one has for $y^n < 0$,

$$\left. \begin{aligned} (\text{adj } Dv)_i^n &= [(\Lambda_{n-1} D\bar{v}) e_n]^i, \\ (\text{adj } Dv)_i^j &= 0 \quad \text{if } j \neq n, \\ \det Dv &= 0. \end{aligned} \right\} \quad (5.6)$$

Hence $v \in A_{p,q}(\Delta \times \mathbb{R})$. Application of Theorem 3.2 gives

$$\int_{\Delta \times \mathbb{R}} \left\{ \left(\frac{\partial}{\partial y^j} \tilde{\eta} \right) (g^i \circ v) (\text{adj } Dv)_i^j + \tilde{\eta} (f \circ v) \det Dv \right\} dx = 0,$$

for all $\tilde{\eta} \in C_0^\infty(\Delta \times \mathbb{R})$. By approximation, the same holds for $\tilde{\eta} \in W_0^{1,\infty}(\Delta \times \mathbb{R})$. Now let

$$\tilde{\eta}(y', y^n) = \begin{cases} \eta(y', y^n), & 0 \leq y^n, \\ (1 + y^n) \eta(y', 0), & -1 \leq y^n < 0, \\ 0, & y^n < -1. \end{cases}$$

Taking into account (5.6) one deduces that the right-hand side of (5.5) is equal to (5.4). This finishes the proof if $f \in C_0^\infty(\mathbb{R}^n)$.

Now assume that $f \in C^\infty(\mathbb{R}^n) \cap L^\infty(\mathbb{R}^n)$ and that f does not have compact support. Then y_0 lies in the unbounded component of $\mathbb{R}^n \setminus \bar{u}(\partial\Omega)$ and hence $\text{deg}(\bar{u}, y_0, \partial\Omega) = 0$. It remains to show that the left-hand side of (5.1) vanishes.

Consider cut-off functions $\varphi_j \in C_0^\infty(\mathbb{R}^n)$ such that $\varphi_j(x) = 1$ if $|x| \leq j$ and let $f_j = \varphi_j f$. As $f_j \in C_0^\infty(\mathbb{R}^n)$ by the result above

$$\int_{\Omega} (f_j \circ u) (\det Du) dx = 0.$$

Thus

$$\left| \int_{\Omega} (f \circ u) \det Du dx \right| \leq \|f\|_\infty \int_{|u| \geq j} |\det Du| dx.$$

Since $q \geq \frac{n}{n-1}$, we have $\det Du \in L^1(\Omega)$ by (1.4). Moreover, because

$$|\{x \in \Omega : |u(x)| \geq j\}| \rightarrow 0 \text{ as } j \rightarrow \infty,$$

$$\int_{\Omega} (f \circ u) \det Du dx = 0$$

as claimed. \square

REFERENCES

[Ad75] R. ADAMS, *Sobolev Spaces*, Academic Press, 1975.
 [Ba77] J. M. BALL, Convexity Conditions and Existence Theorems in Nonlinear Elasticity, *Arch. Rat. Mech. Anal.*, Vol. **63**, 1977, pp. 337-403.
 [Ba81] J. M. BALL, Global Invertibility of Sobolev Functions and the Interpenetration of Matter, *Proc. Roy. Soc. Edinburgh*, Vol. **88A**, 1981, pp. 315-328.
 [Ba82] J. M. BALL, Discontinuous Equilibrium Solutions and Cavitation in Non-Linear Elasticity, *Phil. Trans. Roy. Soc. London*, Vol. **306A**, 1982, pp. 557-612.
 [BM84] J. M. BALL and F. MURAT, $W^{1,p}$ -Quasiconvexity and Variational Problems for Multiple Integrals, *J. Funct. Anal.*, Vol. **58**, 1984, pp. 225-253.

- [Be50] A. S. BESICOVITCH, Parametric Surfaces, *Bull. Am. Math. Soc.*, Vol. **56**, 1950, pp. 228-296.
- [BI83] B. BOJARSKI and T. IWANIEC, Analytical Foundations of the Theory of Quasiconformal Mappings in \mathbb{R}^n , *Ann. Acad. Sci. Fenn.*, Ser. A, Vol. **8**, 1983, pp. 257-324.
- [BFS92] H. BREZIS, N. FUSCO and C. SBORDONE, Integrability of the Jacobian of Orientation Preserving Mappings, *J. Funct. Anal.*, Vol. **115**, 1993, pp. 425-431.
- [CN87] P. G. CIARLET and J. NECAS, Injectivity and Self-Contact in Non-Linear Elasticity, *Arch. Rat. Mech. Anal.*, Vol. **97**, 1987, pp. 171-188.
- [CLMS89] R. COIFMAN, P. L. LIONS, Y. MEYER and S. SEMMES, Compacité par compensation et espaces de Hardy, *C.R. Acad. Sci. Paris*, T. **309**, Serie I, 1989, pp. 945-949; Compensated Compactness and Hardy Spaces, *J. Math Pures Appl.*, Vol. **72**, 1993, pp. 247-286.
- [Da89] B. DACOROGNA, *Direct Methods in the Calculus of Variations*, Springer, 1989.
- [EG91] L. C. EVANS and R. E. GARIEPY, *Lecture Notes on Measure Theory and Fine Properties of Functions*, C.R.C. Publ., 1991.
- [Fe69] H. FEDERER, *Geometric Measure Theory*, Springer, 1969.
- [Fl63] H. FLANDERS, *Differential Forms*, Academic Press, 1963.
- [GT83] D. GILBARG and N. S. TRUDINGER, *Elliptic Partial Differential Equations of Second Order*, Springer, 2nd ed., 1983.
- [Tu84] E. GIUSTI, *Minimal Surfaces and Functions of Bounded Variations*, Birkhäuser, 1984.
- [GI92] L. GRECO and T. IWANIEC, *New Inequalities for the Jacobian*, Preprint.
- [IL92] T. IWANIEC and A. LUTOBORSKI, *Integral Estimates for Null Lagrangians*, Preprint, Syracuse University.
- [IS91] T. IWANIEC and C. SBORDONE, On the Integrability of the Jacobian Under Minimal Hypotheses, *Arch. Rat. Mech. Anal.*, Vol. **119**, 1992, pp. 129-143.
- [MM92] J. MALY and O. MARTIO, *Lusin's Condition (N) and Mappings of the Class $W^{1,n}$* , Preprint.
- [Ma92] J. J. MANFREDI, *Weakly Monotone Functions*, Preprint.
- [Me66] P. A. MEYER, *Probability and Potentials*, Waltham, 1966.
- [MM73] M. MARCUS and V. J. MIZEL, Transformations by Functions in Sobolev Spaces and Lower Semicontinuity for Parametric Variational Problems, *Bull. Amer. Math. Soc.*, Vol. **79**, 1973, pp. 790-795.
- [Mo66] C. B. MORREY, *Multiple Integrals in the Calculus of Variations*, Springer, 1966.
- [MS47] E. J. MCSHANE, *Integration*, Princeton Univ. press, 1947.
- [Mu89] S. MÜLLER, A Surprising Higher Integrability Property of Mappings with Positive Determinant, *Bull. Amer. Math. Soc.*, Vol. **21**, 1989, pp. 245-248.
- [Mu90 a] S. MÜLLER, $\text{Det} = \det$. A Remark on the Distributional Determinant, *C.R. Acad. Sci.*, Paris, Vol. **311**, 1990, pp. 13-17.
- [Mu90 b] S. MÜLLER, Higher Integrability of Determinants and Weak Convergence in L^1 , *J. reine angew. Math.*, Vol. **412**, 1990, pp. 20-34.
- [Mu91 a] S. MÜLLER, A Counter-Example Concerning Formal Integration by Parts, *C.R. Acad. Sci.*, Paris, Vol. **312**, 1991, pp. 45-49.
- [Mu91 b] S. MÜLLER, On the Singular Support of the Distributional Determinant, *Ann. Inst. H. Poincaré, Analyse non linéaire*, Vol. **10**, 1993, pp. 657-696.
- [MS92] S. MÜLLER and S. J. SPECTOR, Existence Theorems in Nonlinear Elasticity Allowing for Cavitation, submitted to *Arch. Rat. Mech. Anal.*
- [MST91] S. MÜLLER, S. J. SPECTOR and Q. TANG, *Invertibility and a Topological Property of Sobolev Maps* (in preparation).
- [Ne67] J. NECAS, *Les méthodes directes en théorie des équations elliptiques*, Masson, 1967.
- [Og72] R. W. OGDEN, Large Deformation Isotropic Elasticity – On the Correlation of Theory and Experiment for Incompressible Rubber-Like Solids, *Proc. Roy. Soc. London*, Vol. **A326**, 1972, pp. 565-584.

- [Re67] Y. G. RESHETNYAK, On the Stability of Conformal Mappings in Multidimensional Spaces, *Siberian Math. J.*, Vol. **8**, 1967, pp. 65-85.
- [Re89] Y. G. RESHETNYAK, *Space Mappings with Bounded Distorsion*, *Transl. Math. Monographs*, Vol. **73**, *Ann. Math. Soc.*, 1989.
- [Ri93] S. RICKMAN, *Quasiregular Mappings*, Springer, 1993.
- [Sc69] J. T. SCHWARTZ, *Nonlinear Functional Analysis*, Acad. Press, 1969.
- [Si83] L. SIMON, *Lectures on Geometric Measure Theory*, Centre Math. Anal. Australian National University, 1983.
- [Sv88] V. ŠVERÁK, Regularity Properties of Deformations with Finite Energy, *Arch. Rat. Mech. Anal.*, Vol. **100**, 1988, pp. 105-127.
- [TQ88] Q. TANG, Almost-Everywhere Injectivity in Nonlinear Elasticity, *Proc. Roy. Soc. Edinburgh*, Vol. **109A**, 1988, pp. 79-95.
- [VG77] S. K. VODOPYANOV and V. M. GOLDSTEIN, Quasiconformal Mappings and Spaces of Functions with Generalised First Derivatives, *Siberian Math. J.*, Vol. **12**, 1977, pp. 515-531.
- [Zh90] K. W. ZHANG, Biting Theorems for Jacobians and their Applications, *Ann. Inst. H. Poincaré, Analyse non linéaire*, Vol. **7**, 1990, pp. 345-365.

(Manuscript received September 14, 1992;
revised June 15, 1993.)