

Lusternik-Schnirelman-theory for Lagrangian intersections

by

H. HOFER (*)

Department of Mathematics, Rutgers University,
New Brunswick, New Jersey 08903

ABSTRACT. — Consider a compact symplectic manifold (M, ω) together with a pair (L, L_1) of isotopic compact Lagrangian submanifolds such that $\pi_2(M, L) = 0$.

Using Gromov's theory of (almost) holomorphic curves the cohomological properties of a family of holomorphic disks are studied. By means of a stretching construction for those disks and a Lusternik-Schnirelman-Theory in compact topological spaces cuplength estimates for the intersection set $L \cap L_1$ are derived.

Key words : Symplectic geometry, Lagrangian intersection problem, holomorphic disks, Lusternik-Schnirelman theory.

RÉSUMÉ. — On examine une variété symplectique compacte (M, ω) , munie d'un couple (L_0, L_1) de sous-variétés lagrangiennes isotopes telles que $\pi_2(M, L) = 0$.

En utilisant la théorie des courbes presque holomorphes, développée par Gromov, on étudie la cohomologie de certaines familles de disques

(*) Research partially supported by N.S.F. Grant DMS-8603149, the Alfred P. Sloan Foundation and a Rutgers's Trustee's Research Fellowship Grant.

holomorphes. On en déduit, par la théorie de Lusternik-Schnirelman, des estimations du cuplength de l'intersection $L_0 \cap L_1$.

I. INTRODUCTION AND STATEMENT OF THE MAIN RESULTS

In recent years much progress has been made in the study of periodic solutions of Hamiltonian systems and symplectic geometry. Since Conley and Zehnder's astounding solution of one of the Arnold conjectures [10] (see [3] for more conjectures and [5], [8], [15]-[18], [20]-[22], [24], [33], [34], [37], [39], [45], [46] for the proofs of some of them) Gromov's idea of using (almost) holomorphic maps to study certain problems in global symplectic geometry had an important impact and led recently to Floer's Morse theory for Lagrangian Intersections in compact symplectic manifolds ([15]-[17]). Moreover the methods are also useful in the study of closed characteristics on compact hypersurfaces in symplectic manifolds (Weinstein-Conjecture), see [19], where results in [25], [26], [42] are proved in more general spaces.

In this paper we shall derive a multiplicity result for certain almost holomorphic discs satisfying some boundary conditions. In fact we shall describe the \mathbb{Z}_2 -cohomology of such a family of discs. This will extend some of Gromov's results [22]. Secondly and most importantly we show that the above multiplicity result together with an approximation result can be used to develop the Lusternik-Schnirelman-Theory for Lagrangian intersections, just complementing Floer's Morse-theory. The approach used here seems to be much simpler than Floer's method which is partially very technical. It has to be seen if it can be used to derive also the Morse-theory. After this work was completed the author received a preprint from A. Floer [50] in which he independently derives the Lusternik-Schnirelman Theory relying heavily on his papers ([15]-[17]). Our approach however, seems to have the advantage of "relative" simplicity.

In order to state our main results we have to fix some notation. Let (M, ω) be a compact symplectic manifold of dimension $2n$ and let L be a compact smooth Lagrangian submanifold of M , i. e. $\dim L = n$ and

$\omega|_L=0$. Given a smooth manifold N (without boundary, say) we say a map $x \rightarrow L_x$ which associates to point $x \in N$ a smooth compact Lagrangian submanifold of M is an exact smooth N -family of compact Lagrangian submanifolds if there exists a smooth map $H: N \times [0, 1] \times M \rightarrow \mathbb{R}$ and a smooth compact Lagrangian submanifold L of M such that

$$L_x = \Phi(x, 1, L) \quad (1)$$

where $\Phi: N \times [0, 1] \times M \rightarrow M$ is the smooth map satisfying

$$\begin{aligned} \omega\left(\frac{\partial}{\partial t}\Phi(x, t, m), \cdot\right) &= d_M H(x, t, \Phi(x, t, m)) \\ \Phi(x, 0, m) &= m \end{aligned} \quad (2)$$

Now let G be a compact convex region of \mathbb{C} with smooth boundary ∂G and let J be an almost complex structure on M such that $g = \omega \circ (\text{Id} \times J)$ is a Riemannian metric (such J 's always exist, see [22]). Let $x \rightarrow L_x$ be an exact smooth ∂G -family of compact Lagrangian submanifolds of M . We define

$$\begin{aligned} \Omega_{G, L, J} = \{u \in C^\infty(G, M) \mid u(x) \in L_x \text{ for } x \in \partial G \\ u_s + J(u)u_t = 0, x = s + it \in G\} \end{aligned} \quad (3)$$

For a point $x_0 \in \partial G$ we define a map

$$\pi_{x_0}: \Omega_{G, L, J} \rightarrow L_{x_0}: u \rightarrow u(x_0). \quad (4)$$

Our first result is the following, where \check{H} denotes Čech cohomology with coefficients in \mathbb{Z}_2 .

THEOREM 1. — *Given (M, ω) , J , G and $x \rightarrow L_x$ as above the set $\Omega_{G, L, J}$ is a compact subset of $C^\infty(G, M)$ equipped with the weak C^∞ -Whitney topology provided $\pi_2(M, L_{x_0}) = 0$ for some $x_0 \in \partial G$. Moreover in this case the map π_{x_0} induces for every $x_0 \in \partial G$ an injective map $\check{\pi}_{x_0}: \check{H}(L_{x_0}) \rightarrow \check{H}(\Omega_{G, L, J})$ in Čech-cohomology. \square*

Remark. — It seems to be not likely that Theorem 1 holds for other coefficients than \mathbb{Z}_2 due to certain orientability questions which arise during the proof (see Theorem 5 in VI). Moreover a refinement of the proof shows that the condition $\pi_2(M, L_{x_0}) = 0$ can be replaced by $[\omega]|_{\pi_2(M, L_{x_0})} = 0$.

Next let $Z = \mathbb{R} + i[0, 1]$ and let \hat{L}_0 and \hat{L}_1 be two compact Lagrangian submanifolds such that $\hat{L}_1 = \Phi(\hat{L}_0)$ for some exact symplectic diffeomor-

phism $\Phi: M \rightarrow M$ (exact means Φ is generated by a time dependent Hamiltonian vectorfield). Let J be as above and put $g = \omega \circ (\text{Id} \times J)$. Define $|\varphi| = g(\varphi, \varphi)^{1/2}$ for $\varphi \in \text{TM}$. We set

$$\Omega_J(\hat{L}_0, \hat{L}_1) = \left\{ u \in C^\infty(Z, M) \mid u_s + J(u) u_t = 0 \right. \\ \left. \int_Z (|u_s|^2 + |u_t|^2) < \infty, u(\mathbb{R}) \subset \hat{L}_0, u(i + \mathbb{R}) \subset \hat{L}_1 \right\} \quad (5)$$

Moreover we define $\pi: \Omega_J(\hat{L}_0, \hat{L}_1) \rightarrow \hat{L}_0: u \rightarrow u(0)$. Then $\Omega_J(\hat{L}_0, \hat{L}_1)$ is a subset of $\Omega(\hat{L}_0, \hat{L}_1) = \{ u \in C^\infty(Z, M) \mid u(\mathbb{R}) \subset \hat{L}_0, u(i + \mathbb{R}) \subset \hat{L}_1 \}$. We equip $\Omega(\hat{L}_0, \hat{L}_1)$ with the topology induced from the weak C^∞ -Whitney topology on $C^\infty(Z, M)$.

THEOREM 2. — *Let (M, ω) , J and \hat{L}_0, \hat{L}_1 be as described above and assume $\pi_2(M, \hat{L}_0) = 0$. Then $\Omega_J(\hat{L}_0, \hat{L}_1)$ is compact and $\tilde{\pi}: \check{H}(\hat{L}_0) \rightarrow \check{H}(\Omega_J(\hat{L}_0, \hat{L}_1))$ is injective.*

In the following we shall call two compact Lagrangian submanifolds equivalent if one is the image of the other by an exact symplectic diffeomorphism.

DEFINITION. — Given a paracompact topological space X we denote by $c(X)$ the \mathbb{Z}_2 -category of X , which is by definition the supremum of all natural numbers k such that there exist cohomology classes μ_1, \dots, μ_{k-1} in $\check{H}(X)$ with $\text{deg}(\mu_i) \geq 1$ and

$$\mu_1 \cup \dots \cup \mu_{k-1} \neq 0$$

where \cup denotes the cup product. We put $c(\emptyset) = 0$. Moreover it is clear that $c(\text{Point}) = 1$.

Our next result is

THEOREM 3. — *Let (M, ω) be a compact symplectic manifold and $\hat{L}_0 \sim \hat{L}_1$ a pair of equivalent compact Lagrangian submanifolds of M such that $\pi_2(M, \hat{L}_0) = 0$. Then $\hat{L}_0 \cap \hat{L}_1$ contains at least $c(\hat{L}_0)$ many points.*

Theorem 3 will be an easy consequence of Theorem 2. Finally we give a fixed point theorem which is a special case of Theorem 3 and which is one of the Arnold conjectures [3].

THEOREM 4. — *Let (M, ω) be a compact symplectic manifold with $\pi_2(M) = 0$. Assume $\Phi: M \rightarrow M$ is an exact symplectic diffeomorphism. Then Φ has at least $c(M)$ fixed points.*

This follows from Theorem 3 applied to $(M \times M, \omega \oplus (-\omega))$, $\hat{L}_0 = \text{diag}(M \times M)$ and $\hat{L}_1 = \text{graph}(\Phi)$.

Remark. — One can prove Theorem 4 directly by a modification of the method used here. In that case using some elementary K-theory to resolve certain orientability questions (which prevented one to use more general coefficients in Theorem 1) one is able to take arbitrary coefficients in the definition of $c(M)$ improving the fixed point estimates. In this direct approach one studies $\bar{\partial}u + g(u) = 0$ for maps $u: G \rightarrow M$, where G is a Riemannian surface diffeomorphic to S^2 (replacing Theorem 1) and $\bar{\partial}u + g(u) = 0$ on $\mathbb{R} \times S^1$ (replacing Theorem 2).

ACKNOWLEDGEMENTS

I wish to thank A. Floer for explaining to me his Morse-theory for Lagrangian intersections. Especially I would like to thank A. Weinstein for carefully reading a first version of the manuscript and many helpful comments.

II. ELLIPTIC ESTIMATES

In this chapter we derive certain *a priori* estimates for solutions of the equation $u_s + J(u)u_t = 0$. Here we follow basically [15], but we impose more general boundary conditions. Moreover we derive the estimates in such a way that they can be used in a crucial approximation result which is used in deriving Theorem 2 from Theorem 1. One could also use Gromov's "geometric" approach to find the estimates [22].

Denote by D either the manifold $\{z \in \mathbb{C} \mid |z| < 1, \text{im}(z) \geq 0\}$ which has boundary $\partial D = (-1, 1)$ or the open unit ball $\{z \in \mathbb{C} \mid |z| < 1\}$. We denote by $\|\cdot\|_l$ the norm defined by

$$\|u\|_l^2 = \int_D |u|^2 ds dt + \sum_{|\alpha|=l} \int_D |D^\alpha u|^2 ds dt \quad (1)$$

where $x = s + it$, $u: D \rightarrow \mathbb{C}^n$ and $\alpha = (\alpha_1, \alpha_2)$ denotes a multi-index. Note that the norm just defined is equivalent to the usual norm where one sums the terms with indices $|\alpha| \leq l$. By $\bar{\partial}_0$ we denote the elliptic differential

operator given by

$$\bar{\partial}_0 u = u_s + i u_t \tag{2}$$

The following is a standard elliptic estimate, see [2].

LEMMA 1. — *For given $j \geq 1$ there exists a constant $c > 0$ such that for every smooth $u: D \rightarrow \mathbb{C}^n$ with compact support in D and $u(\partial D) \subset \mathbb{R}^n$ the following estimate holds*

$$\|u\|_j \leq c \|\bar{\partial}_0 u\|_{j-1} \quad \square \tag{3}$$

Now let (M, ω) and J be as described in chapter I. We equip M with the Riemannian metric $g = \omega \circ (\text{Id} \times J)$. By a result of Nash there exists an isometric embedding of the Riemannian manifold (M, g) into $(\mathbb{R}^N, \langle \cdot, \cdot \rangle)$ for some sufficiently large N . Hence we may assume without loss of generality that M is a submanifold of some \mathbb{R}^N and $g = \langle \cdot, \cdot \rangle|_M$, and that M is equipped with a symplectic structure ω and an almost complex structure J such that $\omega \circ (\text{Id} \times J) = \langle \cdot, \cdot \rangle|_M$. Denote by Γ a smooth submanifold (not necessarily open or closed) of $C = \mathbb{R}^2$ with boundary $\partial\Gamma \subset \Gamma$. For a sufficiently regular map $u: \Gamma \rightarrow \mathbb{R}^N$ with $u(\Gamma) \subset M$ we define a differential operator $\bar{\partial}$ by

$$\bar{\partial}u = u_s + J(u) u_t \tag{4}$$

Given a subset K of Γ we denote by $\text{int}_\Gamma(K)$ the interior of K with respect to Γ . If K is a measurable subset of Γ and $u: \Gamma \rightarrow \mathbb{R}^N$ sufficiently regular we define for $j = 0, 1, \dots$ seminorms $\| \cdot \|_{j, K}$ by

$$\|u\|_{j, K}^2 = \int_K |u|^2 dt ds + \sum_{|\alpha|=j} \int_K |D^\alpha u|^2 ds dt. \tag{5}$$

Let (H_k) be a sequence in $C^\infty(\partial\Gamma \times [0, 1] \times M, \mathbb{R})$ converging to some H . Denote by $x \rightarrow L_x^k$ an associated smooth exact family of compact Lagrangian submanifolds defined by

$$x \rightarrow \Phi^k(x, 1, L) =: L_x^k$$

for some fixed compact Lagrangian L , where, $\Phi^k: \partial\Gamma \times [0, 1] \times M \rightarrow M$ is associated to the Hamiltonian H_k .

PROPOSITION 1. — *Let (u_k) be a sequence of maps from Γ to $M \subset \mathbb{R}^N$ which belongs to $H_{loc}^j(\Gamma, \mathbb{R}^N)$ for some $j \geq 2$ such that*

$$u_k(x) \in L_x^k \quad \text{for all } x \in \partial\Gamma \text{ and } k \in \mathbb{N} \tag{6}$$

where $x \rightarrow L_x^k$ is as described before. Let G be a compact submanifold of C with boundary ∂G such that $G \subset \Gamma$, and assume K is a compact measurable subset of Γ with $K \subset \text{int}_\Gamma(G)$. Assume there is a constant $C > 0$ such that

$$\|u_k\|_{j,G} \leq C \quad \text{for all } k \in \mathbb{N} \quad (7)$$

and moreover

$$\|\bar{\partial}u_k\|_{j-1,G} \rightarrow 0 \quad \text{as } k \rightarrow \infty \quad (8)$$

Then (u_k) is precompact for the seminorms $\|\cdot\|_{j,K}$, i. e. every subsequence of (u_k) has a subsequence which is Cauchy with respect to $\|\cdot\|_{j,K}$.

The following picture illustrates the situation.

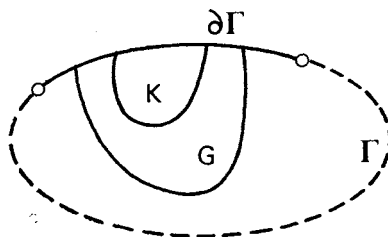

Proof. — Denote by $x \rightarrow L_x$ the family associated to H (recall $H_k \rightarrow H$). Arguing indirectly, using the compact embedding $H^j(G, \mathbb{R}^N) \rightarrow C(G, \mathbb{R}^N)$ for $j \geq 2$ and the compactness of K we find if our assertion is wrong a subsequence of (u_k) for simplicity still denoted by (u_k) and a point $x_0 \in K$ such that

$$\begin{aligned} u_k|_G &\rightarrow u \quad \text{weakly in } H^j(G, \mathbb{R}^N) \\ u_k|_G &\rightarrow u \quad \text{in } C(G, \mathbb{R}^N) \\ u(G) &\subset M, \quad u(x) \in L_x \quad \text{for } x \in G \cap \partial\Gamma \\ \limsup_{k \rightarrow \infty} \|u_k - u\|_{j, B_\varepsilon(x_0) \cap G} &> 0 \quad \text{for every } \varepsilon > 0 \end{aligned} \quad (9)$$

We have to distinguish between the cases $x_0 \in \partial\Gamma$ and $x_0 \notin \partial\Gamma$, where the first case is more difficult. We discuss in detail the first case and leave the second to the reader. It is not difficult to extend the maps $H_k, H: \partial\Gamma \times [0,1] \times M \rightarrow \mathbb{R}$ to maps defined on $\Gamma \times [0,1] \times M$ (which we again denote by the same symbols) such that $H_k \rightarrow H$ in $C^\infty(\Gamma \times [0,1] \times M, \mathbb{R})$ for the weak C^∞ -Whitney topology. Denote by $x \in \Gamma \rightarrow \Phi_x^k = \Phi^k(x, 1, \cdot)$ and $x \in \Gamma \rightarrow \Phi_x$ the associated families of exact symplectic maps and define

$v_k : G \rightarrow M$ by

$$v_k(x) = \Phi_x \circ (\Phi_x^k)^{-1}(u_k(x)), \quad x \in G \quad (10)$$

Clearly

$$v_k(x) \in \Phi_x(L) = L_x \quad \text{for all } x \in G \cap \partial\Gamma \quad (11)$$

Using the facts that $H_k \rightarrow H$, G is a compact subset of Γ , and (u_k) is bounded in $H^j(G, \mathbb{R}^N)$ it is easy to check that

$$\left. \begin{aligned} \|\bar{\partial}v_k\|_{j-1, G} &\rightarrow 0 \quad \text{as } k \rightarrow \infty \\ \|u_k - v_k\|_{j, G} &\rightarrow 0 \quad \text{as } k \rightarrow \infty \end{aligned} \right\} \quad (12)$$

Moreover as a consequence of (9)-(12) we infer

$$\begin{aligned} v_k(x) &\in L_x \quad \text{for all } x \in G \cap \partial\Gamma \\ v_k &\rightharpoonup u \quad \text{weakly in } H^j(G, \mathbb{R}^N) \\ v_k &\rightarrow u \quad \text{in } C(G, \mathbb{R}^N) \\ v_k(G) &\subset M \end{aligned} \quad (13)$$

$$\begin{aligned} \|\bar{\partial}v_k\|_{j-1, G} &\rightarrow 0 \quad \text{as } k \rightarrow \infty \\ \limsup_{k \rightarrow \infty} \|v_k - u\|_{j, B_\varepsilon(x_0) \cap G} &> 0 \quad \text{for every } \varepsilon > 0 \end{aligned}$$

Without loss of generality we may assume $x_0 = 0 \in K \cap \partial\Gamma$. Using the standard Riemann mapping theorem and a regularity result concerned with the boundary behavior, *see* for example [43], we can map D (the half ball) diffeomorphically onto an open neighborhood of 0 in Γ such that $\partial D = (-1, 1)$ is mapped into $\partial\Gamma$ and the diffeomorphism is holomorphic away from ∂D . If we compose (v_k) from the right with this diffeomorphism we may assume that the v_k are defined on D , that G belongs to D and that (13) holds. Then G is a compact neighborhood of o in D . Now we take a parameter depending chart $\varphi : V \times U \rightarrow \mathbb{C}^n$ where V is an open neighborhood of o in D and U is an open neighborhood of $u(o)$ in M such that

$$\begin{aligned} - \varphi(o, u(o)) &= 0; \\ - \varphi(x, U \cap L_x) &\subset \mathbb{R}^n \quad \text{for all } x \in V \cap \partial D; \\ - \varphi &\text{ is smooth and } \varphi_x := \varphi(x, \cdot) : U \rightarrow \mathbb{C}^n \end{aligned} \quad (14)$$

is a chart for every $x \in V$;

$$- T\varphi_o(0)J(u(o))T\varphi_o(o)^{-1} = \text{multiplication by } i.$$

Without loss of generality we may assume in the following that $V=D$. Define w_k by

$$w_k(x) = \varphi(x, v_k(x)) = \varphi_x(v_k(x)) \quad (15)$$

We may assume without loss of generality that all the (w_k) are defined for every $x \in D$. By construction we have

$$w_k(\partial D) \subset \mathbb{R}^n. \quad (16)$$

Now let $\beta: \mathbb{R} \rightarrow [0,1]$ be a smooth map such that $\beta(s) = 1$ for $s \leq \frac{1}{2}$

and $\beta(s) = 0$ for $s \geq \frac{3}{4}$. Put $\beta_\varepsilon(x) = \beta\left(\frac{|x|}{\varepsilon}\right)$ for $x \in \mathbb{C}$ and $\varepsilon > 0$ and define

$\tilde{J}(x, \varphi(x, m)) = T \varphi_x(m) J(m) T \varphi_x(m)^{-1}$. Using Lemma 1 we compute on D with $\delta := w_k - w_l$

$$\begin{aligned} \|\beta_\varepsilon \delta\|_j &\leq c \|\bar{\partial}_0(\beta_\varepsilon \delta)\|_{j-1} \\ &\leq c \|\beta_{\varepsilon, s} \delta + \beta_{\varepsilon, t} i \delta\|_{j-1} + c \|\beta_\varepsilon \bar{\partial}_0 \delta\|_{j-1} \\ &\leq c_1(\varepsilon) \|\delta\|_{j-1} + c \|\beta_\varepsilon(\delta_s + \tilde{J}(x, w_k) \delta_t)\|_{j-1} + c \|\beta_\varepsilon(\tilde{J}(x, w_k) - i) \delta_t\|_{j-1} \\ &\leq c_1(\varepsilon) \|\delta\|_{j-1} + c \|\beta_\varepsilon(\delta_s + \tilde{J}(x, w_k) \delta_t)\|_{j-1} \\ &\quad + c \|\tilde{J}(x, w_k) - i\|_{L^\infty(D_\varepsilon)} \|\beta_\varepsilon \delta_t\|_{j-1} \\ &\quad + c_2(\varepsilon) \|\tilde{J}(x, w_k) - i\|_{j-1} \|\delta\|_{j-1} \quad (17) \end{aligned}$$

Here $L^\infty(D_\varepsilon)$ is the L^∞ -space on the ε -Half ball with the usual essential supremum norm. From (17) we obtain

$$\begin{aligned} (1 - c \|\tilde{J}(x, w_k) - i\|_{L^\infty(D_\varepsilon)}) \|\beta_\varepsilon \delta\|_j \\ \leq c \|\beta_\varepsilon(\delta_s + \tilde{J}(x, w_k) \delta_t)\|_{j-1} + c_3(\varepsilon) \|\delta\|_{j-1} \quad (18) \end{aligned}$$

Here, in general $c_3(\varepsilon) \rightarrow \infty$ as $\varepsilon \rightarrow 0$ whereas c is independent of $\varepsilon > 0$. Since $w_k \rightarrow \varphi(x, u)$ uniformly we see that for $\varepsilon > 0$ small enough [using (14)]

$$\begin{aligned} \frac{1}{2} \|\beta_\varepsilon \delta\|_j &\leq c \|\beta_\varepsilon(\delta_s + \tilde{J}(x, w_k) \delta_t)\|_{j-1} \\ &\quad + c_3(\varepsilon) \|\delta\|_{j-1} + c \|\delta_s + \tilde{J}(x, w_k) \delta_t\|_{j-1} + c_4(\varepsilon) \|\delta\|_{j-1} \quad (19) \end{aligned}$$

Next we have to study the right hand side in (19). We have for suitable constants c_1, c_2, c_3 large enough, since (w_k) and (v_k) are bounded in H_j .

$$\begin{aligned}
 & \|\delta_s + \tilde{J}(x, w_k)\delta_t\|_{j-1} \\
 &= \|(\varphi_s(x, v_k) - \varphi_s(x, v_l)) + T_2 \varphi(x, v_k)v_{k,s} - T_2 \varphi(x, v_l)v_{l,s} \\
 &\quad + \tilde{J}(x, w_k)(T_2 \varphi(x, v_k)v_{k,t} - T_2 \varphi(x, v_l)v_{l,t}) \\
 &\quad + \tilde{J}(x, w_k)(\varphi_t(x, v_k) - \varphi_t(x, v_l))\|_{j-1} \\
 &\leq \|\varphi_s(x, v_k) - \varphi_s(x, v_l)\|_{j-1} + \|\tilde{J}(x, w_k)(\varphi_t(x, v_k) - \varphi_t(x, v_l))\|_{j-1} \\
 &\quad + \|T_2 \varphi(x, v_k)[v_{k,s} + J(v_k)v_{k,t}]\|_{j-1} \\
 &\quad + \|T_2 \varphi(x, v_l)[v_{l,s} + J(v_l)v_{l,t}]\|_{j-1} \\
 &\quad + \|\tilde{J}(x, w_k)T_2 \varphi(x, v_l)v_{l,t} - \tilde{J}(x, w_l)T_2 \varphi(x, v_l)v_{l,t}\|_{j-1} \\
 &\leq c_1 \|v_k - v_l\|_{j-1} + c_2 [\|\bar{\partial}v_k\|_{j-1} + \|\bar{\partial}v_l\|_{j-1}] + c_3 \|\delta\|_{j-1} \quad (20)
 \end{aligned}$$

Combining (19) and (20) gives

$$\|\beta_\epsilon(w_k - w_l)\|_j \rightarrow 0 \quad \text{as } k, l \rightarrow \infty$$

since $\|w_k - w_l\|_{j-1} \rightarrow 0$ and $\|\bar{\partial}v_k\|_{j-1} \rightarrow 0$ tend to zero if $k, l \rightarrow \infty$ as a consequence of (13) and the definition of the w_k . Hence $w_k|_{D_{\epsilon/2}} \rightarrow w|_{D_{\epsilon/2}}$ in H^j . Hence we have for some sufficiently small $\epsilon_0 > 0$

$$\limsup_{k \rightarrow \infty} \|v_k - u\|_{j, B_{\epsilon_0}(x_0) \cap G} = 0$$

contradicting (13). This proves Proposition 1. \square

III. "BLOW-UP ANALYSIS"

Let (M, ω) , J and $x \rightarrow L_x^k, k \in \mathbb{N}$, be as in Proposition 1. We shall show now that under the assumption $\pi_2(M, L) = 0$, where $L_x^k = \Phi_x^k(L)$, a H^1 -bound implies a H^j -bound for the holomorphic maps. The compactness argument uses the phenomenon of "Bubbling off of holomorphic spheres or discs", and which was detected by M. Gromov in his paper [22]. A phenomenon of this kind had been detected earlier for harmonic maps by Sacks and Uhlenbeck [38]. The arguments used here are similar to those used in [15], [48].

PROPOSITION 2. — Let all data be as in Proposition 1 and assume in addition $\pi_2(\mathbf{M}, \mathbf{L}) = 0$. Assume $u_k: \Gamma \rightarrow \mathbf{M}$, $k \in \mathbb{N}$ is a sequence such that for some constant $c > 0$

$$\|u_k\|_{1, \mathbf{G}} \leq c \quad \text{for all } k \in \mathbb{N} \quad (1)$$

and

$$\|\bar{\partial}u_k\|_{j-1, \mathbf{G}} \rightarrow 0 \quad \text{as } k \rightarrow \infty \quad (2)$$

for some $j \geq 2$. Then there exists a constant $c_1 > 0$ such that

$$\|u_k\|_{j, \mathbf{K}} \leq c_1 \quad \text{for all } k \in \mathbb{N} \quad (3)$$

[In particular in view of Proposition 1 (u_k) is precompact for the seminorms $\|\cdot\|_{j, \mathbf{K}}$.]

Proof. — Arguing indirectly we may assume eventually passing to a subsequence of (u_k) that

$$\|u_k\|_{j, \mathbf{K}} \rightarrow \infty \quad \text{as } k \rightarrow \infty. \quad (4)$$

Since \mathbf{M} is compact we have an *a priori* L^2 -bound on (u_k). Hence

$$\|u_k\|_{j, \mathbf{K}} := \left(\sum_{|\alpha|=j} \int_{\mathbf{K}} |D^\alpha u|^2 ds dt \right)^{1/2} \rightarrow \infty \quad (5)$$

Define a sequence (ε_k) , $\varepsilon_k > 0$, by

$$\varepsilon_k = \inf \{ \varepsilon > 0 \mid \exists x \in \mathbf{K} \text{ such that } \varepsilon^{j-1} \|u_k\|_{j, \mathbf{B}_\varepsilon(x) \cap \Gamma} = 1 \} \quad (6)$$

Since (5) holds we must have $\varepsilon_k \rightarrow 0$ as $k \rightarrow \infty$. We pick $x_k \in \mathbf{K}$ with

$$\varepsilon_k^{j-1} \|u_k\|_{j, \mathbf{B}_{\varepsilon_k}(x_k) \cap \Gamma} = 1 \quad (7)$$

Define $r_k = \frac{1}{\varepsilon_k} \text{dist}(x_k, \partial\Gamma)$. Either (r_k) is bounded or unbounded. The second case is easier and left to the reader. Eventually taking a subsequence we may assume that $r_k \rightarrow r \in \mathbb{R}$ as $k \rightarrow \infty$. Eventually taking a subsequence we may assume $x_k \rightarrow x_0 \in \mathbf{K}$ and without loss of generality $x_0 = 0$. As in Proposition 1 composing u_k from the right with a fixed suitable holomorphic map $D \setminus \partial D \rightarrow \Gamma \setminus \partial\Gamma$ extending smoothly to ∂D and mapping ∂D into $\partial\Gamma$ and D diffeomorphically into Γ we may assume that $D \subset \Gamma$ and $\partial D \subset \partial\Gamma$. Denote by D_R the open half ball of radius R around o in the closed upper half plane. We find a sequence $(\Delta_k) \subset \mathbb{R}$ such that the

maps

$$x \rightarrow x_k + (\varepsilon_k + \Delta_k)(x - x_k - r)$$

map D_R into $D = D_1$ for k large enough (and ∂D_R into ∂D). In fact let Δ_k satisfy

$$(r + \text{im}(x_k)) \Delta_k = \text{im}(x_k) - \varepsilon_k(r + \text{im}(x_k)).$$

If $r = 0 = \text{im}(x_k)$ we take $\Delta_k = 0$. Clearly, noting that $\text{dist}(x_k, \Gamma) = \text{im}(x_k)$ at least if k is large enough, by our assumption $x_k \rightarrow 0 \in D \subset \Gamma$, we must have $\Delta_k/\varepsilon_k \rightarrow 0$ as $k \rightarrow \infty$. Define $v_k: D_R \rightarrow M$ by

$$v_k(x) = u_k(x_k + (\varepsilon_k + \Delta_k)(x - x_k - r))$$

for k sufficiently large. Obviously

$$v_k(x) \in L^k_{(x_k + (\varepsilon_k + \Delta_k)(x - x_k - r))} \quad \text{for } x \in \partial D_R$$

Put $\delta_k = \varepsilon_k/(\Delta_k + \varepsilon_k)$, then we have

$$\begin{aligned} \int_{D_R} (|v_{k,s}|^2 + |v_{k,t}|^2) ds dt &\leq c \\ \delta_k^{-(j-1)} |v_k|_{j, B_{\delta_k}(x_k+r) \cap D_R} &= 1 \\ \delta_k^{-(j-1)} |v_k|_{j, B_{\delta_k}(x) \cap D_R} &\leq 1 \quad \text{for all } x \in D_{R-1} \\ \|\bar{\partial} v_k\|_{j-1, D_R} &\rightarrow 0 \quad \text{as } k \rightarrow \infty \end{aligned}$$

Consider the family of maps $\tilde{H}_k: \partial D_R \times [0, 1] \times M \rightarrow \mathbb{R}$ defined by

$$\tilde{H}_k(x, t, m) = H_k(x_k + (\varepsilon_k + \Delta_k)(x - x_k - r), t, m)$$

Since $H_k \rightarrow H$ in the weak C^∞ -Whitney topology and $x_k \rightarrow 0$, $\Delta_k + \varepsilon_k \rightarrow 0$ we see that $\tilde{H}_k \rightarrow \tilde{H}$, where \tilde{H} is defined by

$$\tilde{H}(x, t, m) = H(0, t, m)$$

Now applying Proposition 1 with $\Gamma = D_R$, some suitable G containing in its interior D_{R-1} we see that (v_k) is precompact for $\|\cdot\|_{j, D_{R-1}}$. We can carry out the same construction for every $R > 0$. Hence we can construct a smooth map $v: \mathbb{C}^+ := \{z \in \mathbb{C} \mid \text{im}(z) \geq 0\} \rightarrow M$ such that

$$(i) \int_{\mathbb{C}^+} (|v_s|^2 + |v_t|^2) \leq c;$$

- (ii) $|v|_{j, B_1(r) \cap \mathbb{C}^+} = 1$;
- (iii) $|v|_{j, B_1(x) \cap \mathbb{C}^+} \leq 1$ for all $x \in \mathbb{C}^+$; (8)
- (iv) $\bar{\partial}v = 0$;
- (v) $v(\mathbb{R}) \subset L_{x_0} = L_0$

(That v is smooth follows from standard elliptic regularity theory or just use Lemma 1 and a chart.) We shall construct now using (8) a smooth map $(B, \partial B) \rightarrow (M, L_0)$ such that

$$0 < \int_B w^* \omega \quad (9)$$

where B is the closed unit ball in \mathbb{C} . By our assumption that $\omega|_{L_0} = 0$ and $\pi_2(M, L) = 0$ ($\Rightarrow \pi_2(M, L_0) = 0$) we must have

$$0 = \int_B w^* \omega \quad (10)$$

contradicting (9). This contradicting will imply the assertions of Proposition 2 for the case that $x_0 \in (\partial\Gamma) \cap K$. Now in order to construct w observe that for every $\delta > 0$ there exists $R > \frac{1}{\delta}$ such that the path $t \rightarrow v(\operatorname{Re}^{it})$ starting and ending at a point in L_0 has length less than δ . This follows immediately from (8) (i) using Polar coordinates. Moreover using (iv) we have

$$\int_{D_R} (|v_s|^2 + |v_t|^2) ds dt = 2 \int_{D_R} v^* \omega$$

Since by (ii) v is non-constant this implies that $\int_{D_R} v^* \omega > 0$ for R large enough and that this integral is increasing in R . Now it is obvious that v can be used to construct a map $w: (B, \partial B) \rightarrow (M, L_0)$ satisfying $\int_B w^* \omega > 0$.

If $r_k \rightarrow \infty$ as $k \rightarrow \infty$ one obtains by the same procedure a map $v: \mathbb{C} \rightarrow M$ satisfying 8(i)-(iv) with \mathbb{C}^+ being replaced by \mathbb{C} . This can be used to

construct a map $w: S^2 \rightarrow M$ such that $\int w^* \omega > 0$ which contradicts $\pi_2(M, L) = 0$ again.

In order to construct the map w one can also, starting with (8), employ a removable singularity theorem ([22], [37]).

IV. AN APPROXIMATION RESULT AND PROOF OF THEOREM 2 ASSUMING THEOREM 1

In the following we work under the assumptions of Theorem 2. Define as before $Z = \mathbb{R} + i[0, 1]$ and put for $\xi > 0$, $Z_\xi = (-\xi, \xi) + i[0, 1]$ with boundary $\partial Z_\xi = (-\xi, \xi) \cup (i + (-\xi, \xi))$. Let $\beta: \mathbb{R} \rightarrow \mathbb{R}$ be a smooth map such that $\beta(s) = 1$ for $s \leq \frac{1}{2}$ and $\beta(s) = 0$ for $s \geq \frac{3}{2}$. For $\varepsilon > 0$ define

$$\beta_\varepsilon(s) = \beta\left(\frac{|s|}{\varepsilon}\right)$$

Define for $\xi > 0$ and $a \geq 0$ a subset $\Omega_{\xi, a}$ of $C^\infty(Z_\xi, M)$ equipped with the weak C^∞ -Whitney topology by

$$\Omega_{\xi, a} = \left\{ u \in C^\infty(Z_\xi, M) \mid \bar{\partial}u = 0, u((-\xi, \xi)) \subset \hat{L}_0, \right. \\ \left. u(i + (-\xi, \xi)) \subset \hat{L}_1, \int_{Z_\xi} (|u_s|^2 + |u_t|^2) ds dt \leq a \right\}$$

where $\hat{L}_0 - \hat{L}_1$ are given in Theorem 2. We define a continuous map $r_\xi: \Omega_{\xi, a} \rightarrow \Omega(\hat{L}_0, \hat{L}_1)$ by

$$r_\xi(u)(s + it) = u(\beta_\xi(s)s + it)$$

PROPOSITION 3. — *Given any open neighborhood U of $\Omega_1(\hat{L}_0, \hat{L}_1)$ and a number $a \geq 0$ there exists $\xi_0 > 0$ such that*

$$r_\xi(\Omega_{\xi, a}) \subset U \quad \text{for every } \xi \geq \xi_0$$

Proof. — We can consider $C^\infty(Z, M)$ and $C^\infty(Z_\xi, M)$ as (nonlinear) subspaces of the Frechet spaces $C^\infty(Z, \mathbb{R}^N)$ and $C^\infty(Z_\xi, \mathbb{R}^N)$, respectively.

The latter are assumed to be equipped with their usual seminorms. Arguing indirectly, i.e. assuming the result to be false, we find now sequences $\xi_k \rightarrow \infty$ and (u_k) , $u_k \in \Omega_{\xi_k, a}$ such that

$$r_{\xi_k}(u_k) \notin U$$

Fix any $\tilde{\xi} > 0$. Then we have for k large enough

$$\begin{aligned} r_{\xi_k}(u_k) &= u_k \quad \text{on } cl(Z_{\tilde{\xi}}) \\ u_k((-\tilde{\xi}, \tilde{\xi})) &\subset \hat{L}_0, \quad u_k(i + (-\tilde{\xi}, \tilde{\xi})) \subset L_1 \\ \int_{Z_{\tilde{\xi}}} (|u_{k,s}|^2 + |u_{k,t}|^2) ds dt &\leq a \\ \bar{\partial}u_k &= 0 \quad \text{on } Z_{\tilde{\xi}} \end{aligned} \quad (1)$$

Employing Proposition 2 we have for every $j \geq 2$ a H^j -bound on $Z_{\tilde{\xi}/2}$. Since $\tilde{\xi}$ is arbitrary we find for every $N \in \mathbb{N}$ and $j \in \mathbb{N}$, $j \geq 2$, a number $c(N, j) > 0$ such that

$$\|r_{\xi_k}(u_k)\|_{j, Z_N} \leq c(N, j)$$

Since on a bounded sufficiently regular domain $\cap H^j = C^\infty$ by the Sobolev embedding theorem we infer that $(r_{\xi_k}(u_k))$ is precompact in $\Omega(\hat{L}_0, \hat{L}_1)$. Taking a suitable subsequence and using (1) we see that the limit $v \in \Omega(\hat{L}_0, \hat{L}_1)$ of this subsequence must satisfy

$$\begin{aligned} v(\mathbb{R}) &\subset \hat{L}_0, \quad v(i + \mathbb{R}) \subset \hat{L}_1 \\ \bar{\partial}v &= 0 \\ \int (|v_s|^2 + |v_t|^2) ds dt &\leq a \end{aligned} \quad (2)$$

Hence $v \in \Omega_j(\hat{L}_0, \hat{L}_1)$ which contradicts the fact that $r_{\xi_k}(u_k) \notin U$.

Now let G be a convex compact submanifold of \mathbb{C} with smooth boundary ∂G such that $\partial G \cap \partial Z = [-1, 1] \cup (i + [-1, 1])$. Put

$$G_- = G \cap ((-\infty, 0] + i[0, 1]) \quad \text{and} \quad G_+ = G \cap ([0, +\infty) + i[0, 1]).$$

For $\xi > 0$ we define a smooth compact domain with boundary by

$$G_\xi = (-\xi + G_-) \cup ([-\xi, \xi] + i[0, 1]) \cup (\xi + G_+)$$

Observe that $G_\xi \subset Z$ and $G_\xi \cap Z_\xi = Z_\xi$ where Z_ξ has been previously defined. Now we fix an exact smooth ∂G -family of compact Lagrangian submanifolds of M , say $x \rightarrow L_x$ such that $L_x \simeq \hat{L}_0$ and

$$\begin{aligned}
 [x \rightarrow L_x] | [-1, 1] &= \hat{L}_0 \\
 [x \rightarrow L_x] | i + [-1, 1] &= \hat{L}_1
 \end{aligned}$$

and such that the parameter dependent Hamiltonian

$$H: \partial G_\xi \times [0, 1] \times M \rightarrow \mathbb{R} \text{ generating } x \rightarrow L_x$$

satisfies

$x \rightarrow H(x, \cdot, \cdot)$ is constant, i. e. independent of x ,
 on $[-1, 1]$ and on $i + [-1, 1]$.

Since $\hat{L}_0 \sim \hat{L}_1$ this can be done. The above family $x \rightarrow L_x$ induces also a family L^ξ on every G_ξ by defining

$$\begin{aligned}
 L^\xi(-\xi + x) &= L_x & \text{for } x \in G_- \cap \partial G \\
 L^\xi(\xi + x) &= L_x & \text{for } x \in G_+ \cap \partial G \\
 L_x^\xi &= L_0 & \text{on } (-\xi, \xi) \\
 L_x^\xi &= \hat{L}_1 & \text{on } i + (-\xi, \xi)
 \end{aligned}$$

Note that the family $x \rightarrow L_x^\xi$ is defined by an obvious Hamiltonian H^ξ obtained from H so that $x \rightarrow H^\xi(x, \cdot, \cdot)$ is constant on the boundary portions $[-\xi, \xi]$ and $i + [-\xi, \xi]$. The following picture shows the stretching construction.

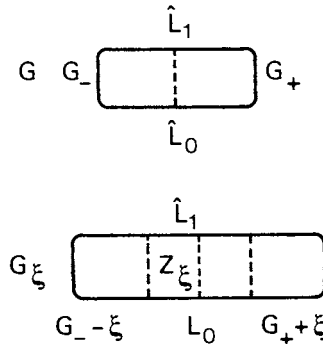

We need the following

LEMMA 2. — *There exists a constant $a \geq 0$ such that for every $\xi > 0$ the following holds: If $u \in \Omega_{G_\xi, L^\xi, J}$ then*

$$\int_{G_\xi} (|u_s|^2 + |u_t|^2) ds dt \leq a$$

Proof. — Observe that for $u \in \Omega_{G_\xi}$ we have

$$\int_{G_\xi} (|u_s|^2 + |u_t|^2) ds dt = 2 \int_{G_\xi} u^* \omega.$$

By the definition of $x \rightarrow L_x^\xi$ there exists a smooth map

$$\Phi^\xi: \partial G_\xi \times [0, 1] \times M \rightarrow M$$

generated by the smooth map

$$H^\xi: \partial G_\xi \times [0, 1] \times M \rightarrow \mathbb{R}$$

such that

$$L_x^\xi = \Phi^\xi(x, 1, L) \tag{3}$$

and

$$\begin{aligned} \omega \left(\frac{\partial}{\partial t} \Phi^\xi(x, t, m), \cdot \right) &= d_M H^\xi(x, t, \Phi^\xi(x, t, m)) \\ \Phi^\xi(x, 0, m) &= m \end{aligned} \tag{4}$$

for $(x, t, m) \in \partial G_\xi \times [0, 1] \times M$. By our assumption $\pi_2(M, L) = 0$. By the construction of the family $x \rightarrow L_x^\xi$ it follows immediately that any two maps $u: G_\xi \rightarrow M$ with $u(x) \in L_x^\xi$ for $x \in \partial G_\xi$ are homotopic. Now let $\Theta: [0, 1] \times G_\xi \rightarrow M$ be a smooth map satisfying $\Theta(\sigma, x) \in L_x^\xi$ for $(\sigma, x) \in [0, 1] \times \partial G_\xi$. Using that $d\omega = 0$ we find by Stokes' Theorem

$$\int_{G_\xi} \Theta(1, \cdot)^* \omega - \int_{G_\xi} \Theta(0, \cdot)^* \omega = \int_{[0, 1] \times \partial G_\xi} \Theta^* \omega. \tag{5}$$

We pick a smooth map $v: [0, 1] \times \partial G_\xi \rightarrow M$ satisfying

$$\Theta(\sigma, x) = \Phi^\xi(x, 1, v(\sigma, x)) \tag{6}$$

Define $\tilde{\Theta}: [0, 1] \times [0, 1] \times \partial G_\xi \rightarrow M$ by

$$\tilde{\Theta}(t, \sigma, x) = \Phi^\xi(x, t, v(\sigma, x)) \tag{7}$$

Again by Stokes' Theorem using that $d\omega=0$ and $\tilde{\Theta}(o, \sigma, x)=v(\sigma, x)$ with image $(v) \subset L$ and $\omega|_L=0$ we compute

$$\int_{[0, 1] \times \partial G_\xi} \tilde{\Theta}(1, ., .)^* \omega = \int_{[0, 1] \times \{1\} \times \partial G_\xi} \tilde{\Theta}^* \omega - \int_{[0, 1] \times \{0\} \times \partial G_\xi} \tilde{\Theta}^* \omega \quad (8)$$

Here combining (5) and (8) gives

$$\begin{aligned} \int_{G_\xi} \Theta(1, .)^* \omega - \int_{G_\xi} \Theta(0, .)^* \omega \\ = \int_{[0, 1] \times \{1\} \times \partial G_\xi} \tilde{\Theta}^* \omega - \int_{[0, 1] \times \{0\} \times \partial G_\xi} \tilde{\Theta}^* \omega \quad (9) \end{aligned}$$

We have to compute the right hand side. For $i=0, 1$ we have

$$\begin{aligned} (\tilde{\Theta}(\cdot, i, \cdot)^* \omega)(t, x) &= dt \wedge \left[\omega \left(\frac{\partial \Phi^\xi}{\partial t}(x, t, v(i, x)), D_3 \Phi^\xi(t, i, x) \right) \right] \\ &= dt \wedge [D_3 H^\xi(x, t, \Phi^\xi(x, t, v(i, x))) (D_3 \Phi^\xi(t, i, x)).] \\ &= dt \wedge \left[\frac{\partial}{\partial x} (H^\xi(x, t, \Phi^\xi(x, t, v(i, x)))) dx \right] \\ &\quad - dt \wedge [(D_1 H^\xi)(x, t, \Phi^\xi(x, t, v(i, x))).] \quad (10) \end{aligned}$$

Hence

$$\begin{aligned} \int_{[0, 1] \times \partial G_\xi} \tilde{\Theta}(\cdot, i, \cdot)^* \omega \\ = - \int_{[0, 1] \times \partial G_\xi} dt \wedge [(D_1 H^\xi)(x, t, \Phi^\xi(x, t, v(i, x))).] \quad (11) \end{aligned}$$

Now observe that $x \rightarrow H^\xi(x, ., .)$ is constant on $[-\xi, \xi]$ and $i+[-\xi, \xi]$. So it follows immediately that there are constants $c_i > 0, i=0, 1$ such that

$$\left| \int_{[0, 1] \times \partial G_\xi} \tilde{\Theta}(\cdot, i, \cdot)^* \omega \right| \leq c_i \quad (12)$$

where the constant is independent of $\xi > 0$. Hence we infer from (9)

$$\left| \int_{G_\xi} \Theta(1, .)^* \omega - \int_{G_\xi} \Theta(0, .)^* \omega \right| \leq c_0 + c_1 = : c_2 \quad (13)$$

Where the constant $c_2 > 0$ is independent of $\xi > 0$. In order to complete the proof we have to give a constant $c_3 > 0$ and for every $\xi > 0$ a map $u^\xi: G_\xi \rightarrow M$ such that $u^\xi(x) \in L_x^\xi$ for $x \in \partial G_\xi$ and

$$\left| \int_{G_\xi} (u^\xi)^* \omega \right| \leq c_3 \quad (14)$$

Combining (13) and (14) will give us

$$\left| \int_{G_\xi} u^* \omega \right| \leq c_2 + c_3 =: \frac{1}{2} a \quad (15)$$

If now $u \in \Omega_{G_\xi, L^\xi, J}$ we have

$$\int_{G_\xi} (|u_s|^2 + |u_t|^2) ds dt = 2 \int_{G_\xi} u^* \omega \leq 2 \frac{1}{2} a = a$$

which will complete the proof. Fix a map $\hat{u}: G \rightarrow M$ such that $\hat{u}(x) \in L_x$ for $x \in \partial G$ and $\hat{u}(s+it) = \hat{u}(it)$ for $s \in [-1, 1]$. We obtain induced maps u^ξ by defining

$$\begin{aligned} u^\xi(-\xi+x) &= \hat{u}(x) & \text{for } x \in G \\ u^\xi(\xi+x) &= u(x) & \text{for } x \in G_+ \\ u^\xi(s+it) &= \hat{u}(it) & \text{for } s \in [-\xi, \xi], t \in [0, 1] \end{aligned} \quad (16)$$

We compute

$$\begin{aligned} \int_{G_\xi} (u^\xi)^* \omega &= \int_{-\xi+G_-} (u^\xi)^* \omega + \int_{\xi+G_+} (u^\xi)^* \omega + \int_{[-\xi, \xi]+i[0, 1]} (u^\xi)^* \omega \\ &= \int_{G_-} \hat{u}^* \omega + \int_{G_+} \hat{u}^* \omega = \int_G \hat{u}^* \omega \end{aligned}$$

This completes the proof of Lemma 2. \square

It is worthwhile to note the following corollary to the proof of Lemma 2 and the Propositions 1 and 2.

PROPOSITION 4. — *Let (M, ω) , J and G be as in Theorem 1. Let (H_k) be a sequence of smooth maps $\partial G \times [0, 1] \times M \rightarrow \mathbb{R}$ converging to some H in the weak C^∞ -Whitney topology. Denote a corresponding exact ∂G -families of compact Lagrangian submanifolds by $x \rightarrow L_x^k$ and $x \rightarrow L_x$, respectively.*

Let $u_k: G \rightarrow M$, be a sequence of maps in $H^j(G^k, \mathbb{R}^N)$, $j \geq 2$, such that $u_k(x) \in L_x^k$ for $x \in \partial G$ and $\|\bar{\partial}u_k\|_{j-1, G} \rightarrow 0$ as $k \rightarrow \infty$. If $\pi_2(M, L) = 0$ then (u_k) is precompact in $H^j(G, \mathbb{R}^N)$.

Proof. — By the proof of Lemma 2 (11) we find a constant $a_1 > 0$ such that

$$\left| \int_G u_k^* \omega \right| \leq a_1$$

Since $\|\bar{\partial}u_k\|_{j-1, G} \rightarrow 0$ we infer that

$$\int_G [|u_{k,s}|^2 + |u_{k,t}|^2] ds dt \leq a_2$$

for some constant $a_2 > 0$ independent of k . Now applying Proposition 1 and Proposition 2 with $\Gamma = G = K$ we find that (u_k) is precompact in $H^j(G, \mathbb{R}^N)$. \square

Now we complete this chapter by proving Theorem 2 assuming Theorem 1.

Proof Theorem 2: injectivity of π . — Let G_ξ for $\xi > 0$ be as previously constructed. Let the constant $a > 0$ be as in Lemma 2. Given an open neighborhood U of $\Omega_j(\hat{L}_0, \hat{L}_1)$ in $\Omega(\hat{L}_0, \hat{L}_1)$ we find by Proposition 3 a number $\xi_0 > 0$ such that for every $\xi \geq \xi_0$

$$r_\xi(\Omega_\xi, a) \subset U$$

For $u \in \Omega_{G_\xi, L^\xi, J}$ where $\xi \geq \xi_0$ the restrictions $u|_{Z_\xi}$ belongs to $\Omega_{\xi, a}$ by Lemma 2. Hence we have for $\xi \geq 0$ the commutative diagram

$$\begin{array}{ccccc} \Omega_{G_\xi, L^\xi, J} & \xrightarrow{|Z} & \Omega_{\xi, a} & \xrightarrow{r_\xi} & U \\ & \searrow \pi_0 & & & \downarrow \pi_U \\ & & & & \hat{L}_0 \end{array}$$

where π_0 and π_u are the maps “evaluation at 0”. By Theorem 1 $\tilde{\pi}_0: \check{H}(\hat{L}_0) \rightarrow \check{H}(\Omega_{G_\xi, L^\xi, J})$ is injective, hence π_U is injective for every open neighborhood U of $\Omega_j(\hat{L}_0, \hat{L}_1)$ in $\Omega(\hat{L}_0, \hat{L}_1)$. By the continuity property of Cech cohomology $\tilde{\pi}: \check{H}(\hat{L}_0) \rightarrow \check{H}(\Omega_j(\hat{L}_0, \hat{L}_1))$ is injective since $\Omega_j(\hat{L}_0, \hat{L}_1)$ is a metrisable space. \square

In view of Proposition 1 and Proposition 2 we have only to show the existence of a constant $a > 0$ such that

$$\int_Z u^* \omega \leq a \quad (17)$$

for every $u \in \Omega_J(\hat{L}_0, \hat{L}_1)$ in order to conclude the compactness of $\Omega_J(\hat{L}_0, \hat{L}_1)$.

Denote by $\Sigma(\hat{L}_0, \hat{L}_1)$ the space of all smooth maps $\gamma: [0, 1] \rightarrow M$ with $\gamma(i) \in L_i$ for $i=0, 1$ equipped with the topology induced from $C^\infty([0, 1], M)$. We call a curve γ in $\Sigma(\hat{L}_0, \hat{L}_1)$ contractible if there is a smooth map $\Theta: [0, 1] \times [0, 1] \rightarrow M$ such that

$$\begin{aligned} \Theta(\tau, 0) \in \hat{L}_0, \quad \Theta(\tau, 1) \in \hat{L}_1 \quad \text{for all } t \in [0, 1] \\ \Theta(0, t) = \text{const.}, \quad \Theta(1, t) = \gamma(t) \end{aligned}$$

Denote by $\Sigma_0(\hat{L}_0, \hat{L}_1)$ the subset of $\Sigma(\hat{L}_0, \hat{L}_1)$ consisting of contractible curves. Clearly $\Sigma_0(\hat{L}_0, \hat{L}_1)$ could be *a priori* empty.

LEMMA 3. — Let (M, ω) , J , $\hat{L}_0 \sim \hat{L}_1$ be as in Theorem 2 and assume $\pi_2(M, \hat{L}_0) = 0$. Then there exists a continuous map $\alpha: \Sigma_0(\hat{L}_0, \hat{L}_1) \rightarrow \mathbb{R}$ such that for every smooth map $v: [0, 1] \times [0, 1] \rightarrow \mathbb{R}$ with $v(\tau, 0) \in \hat{L}_0$ and $v(\tau, 1) \in \hat{L}_1$ for every $\tau \in [0, 1]$ the following holds

$$\alpha(v(1, \cdot)) - \alpha(v(0, \cdot)) = \int_{[0, 1] \times [0, 1]} v^* \omega$$

provided the induced maps $t \rightarrow v(i, t)$, $i=0, 1$ belong to $\Sigma_0(\hat{L}_0, \hat{L}_1)$.

Proof. — We can define α on every component of $\Sigma_0 = \Sigma_0(\hat{L}_0, \hat{L}_1)$ separately. Fix, if $\Sigma_0 \neq \emptyset$ a point $x_0 \in \hat{L}_0 \cap \hat{L}_1$ representing a component of Σ_0 . Let $t \rightarrow \Phi_t$ be an exact isotopy of the identity in $D_\omega(M)$ such that $\Phi_1(\hat{L}_0) = \hat{L}_1$. Note also that $\Phi_1(x_0) = x_0$. Given a smooth map $\gamma \in \Sigma_0$ in the component associated to x_0 let $\tilde{\gamma}: [0, 1] \times [0, 1] \rightarrow M$ be a smooth map such that

$$\begin{aligned} \tilde{\gamma}(0, t) = \Phi_t(x_0), \quad \tilde{\gamma}(1, t) = \gamma(t) \\ \tilde{\gamma}(\tau, 0) \in \hat{L}_0, \quad \tilde{\gamma}(\tau, 1) \in \hat{L}_1 \end{aligned}$$

for every $\tau, t \in [0, 1]$. Define

$$\alpha(\gamma) := \int \tilde{\gamma}^* \omega \quad (18)$$

Clearly we have to show that the definition (18) does not depend on the choice of $\tilde{\gamma}$. For this let $S' = [0, 1] / \{0, 1\}$ and let $\tilde{\gamma}: S' \times [0, 1] \rightarrow M$ be a smooth map such that

$$\left. \begin{aligned} \tilde{\gamma}(\tau, t) \in \hat{L}_i & \quad \text{for } i=0, 1 \text{ and } \tau \in S' \\ \tilde{\gamma}(0, t) = \Phi_t(x_0) & \quad \text{for } t \in [0, 1]. \end{aligned} \right\} \quad (19)$$

α will be well defined if we can show that $\int \tilde{\gamma}^* \omega = 0$. Define $\delta: S' \times [0, 1] \rightarrow M$ by

$$\Phi_t \circ \delta(\tau, t) = \tilde{\gamma}(\tau, t) \quad (20)$$

Define a homotopy $\tilde{\delta}: [0, 1] \times S' \times [0, 1] \rightarrow M$ by

$$\tilde{\delta}(s, \tau, t) = \Phi_{st} \circ \delta(\tau, t) \quad (21)$$

The following picture describes the homotopy $\tilde{\delta}$

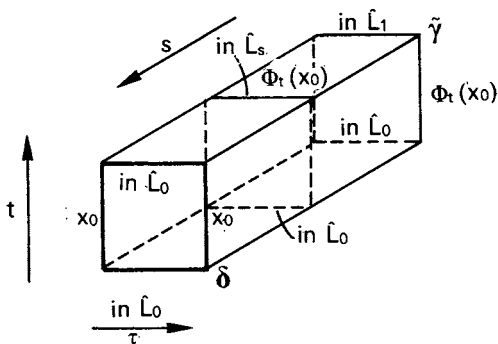

Bottom is in \hat{L}_0 and right and left side cancel since τ is circular.

Using Stokes' Theorem and $d\omega = 0$ we compute

$$\int_{S' \times [0, 1]} \tilde{\gamma}^* \omega - \int_{S' \times [0, 1]} \delta^* \omega = \int_{[0, 1] \times S' \times \{1\}} \tilde{\delta}^* \omega - \int_{[0, 1] \times S' \times \{0\}} \tilde{\delta}^* \omega$$

Since $\tilde{\delta}(s, \tau, 0) = \delta(\tau, 0) \in \hat{L}_0$ for all $(s, \tau) \in [0, 1] \times S'$ and $\omega|_{\hat{L}_0} = 0$ we must have

$$\int_{S' \times [0, 1]} \tilde{\gamma}^* \omega - \int_{S' \times [0, 1]} \delta^* \omega = \int_{[0, 1] \times S' \times \{1\}} \tilde{\delta}^* \omega \quad (22)$$

Now $\tilde{\delta}(s, \tau, 1) = \Phi_s \circ \delta(\tau, 1)$. Let $H: [0, 1] \times M \rightarrow \mathbb{R}$ be a Hamiltonian generating $t \rightarrow \Phi_t$. Then with $F(s, \tau) = H(s, \Phi_s \circ \delta(\tau, 1))$ we have

$$\tilde{\delta}(\cdot, \cdot, 1)^* \omega = ds \wedge dF$$

which implies that the right hand side in (22) is zero. Consequently

$$\int_{S' \times [0, 1]} \tilde{\gamma}^* \omega = \int_{S' \times [0, 1]} \delta^* \omega \quad (23)$$

Now $\delta: S' \times [0, 1] \rightarrow M$ satisfies $\delta(\tau, 0), \delta(\tau, 1) \in \hat{L}_0$ for every $\tau \in S'$ and $\delta(o, t) = x_0$ for every $t \in [0, 1]$. Hence we can consider δ as a map from the closed unit disc B into M mapping ∂B into \hat{L}_0 . By the assumption $\pi_2(M, \hat{L}_0) = 0$ δ is homotopic to a constant map $(B, \partial B) \rightarrow (M, \hat{L}_0)$. Since $\omega|_{\hat{L}_0} = 0$ this implies that the right hand side of (23) is zero. This shows that $\alpha(\gamma)$ is well defined. The continuity of α is trivial. Now let $v: [0, 1] \times [0, 1] \rightarrow M$ be a map as on the statement of Lemma 3. Extend it to a map $\tilde{v}: [-1, 2] \times [0, 1] \rightarrow M$ such that

$$\begin{aligned} \tilde{v}(\tau, i) &\in \hat{L}_i, & i=0, 1 & \text{ and } \tau \in [-1, 2] \\ \tilde{\gamma}(-1, t) &= \Phi_t(x_0), & \tilde{\gamma}(2, t) &= \Phi_t(x_0) \end{aligned}$$

Then \tilde{v} induces a map $S' \times [0, 1] \rightarrow M$ satisfying (19). Consequently, taking orientations into consideration

$$0 = \int_{[-1, 2] \times [0, 1]} \tilde{v}^* \omega = \alpha(v(0, \cdot)) - \alpha(v(1, \cdot)) + \int_{[0, 1] \times [0, 1]} v^* \omega$$

which is the desired result. \square

Proof of Theorem 2: compactness. — Given $u \in \Omega_j(\hat{L}_0, \hat{L}_1)$ and $\delta > 0$ we find since $2 \int_Z u^* \omega = \int_Z (|u_s|^2 + |u_t|^2) ds dt < \infty$ numbers $R_1, R_2 \in \mathbb{R}$ such that

$$-R_1 > \frac{1}{\delta}, \quad R_2 > \frac{1}{\delta}$$

and

$$\left| \int_Z u^* \omega - \int_{[R_1, R_2] + i[0, 1]} u^* \omega \right| \leq \delta; \quad (24)$$

length of $t \rightarrow u(R_j + it), j = 1, 2$ is less than δ .

If δ is small enough the end points of the pathes $t \rightarrow u(\mathbb{R}_j + it)$ must be close to intersection points in $\hat{L}_0 \cap \hat{L}_1$. This shows that all the curves $t \rightarrow u(\tau + it)$ belong to $\Sigma_0(\hat{L}_0, \hat{L}_1)$. Using these observations it is trivial to construct for a given $1 > \varepsilon > 0$ a map $v: [-1, 1] + i[0, 1] \rightarrow M$ such that

$$\left| \int_Z u^* \omega - \int_{[-1, 1] + i[0, 1]} v^* \omega \right| \leq \varepsilon \tag{25}$$

and

$$\begin{aligned} v(\tau) \in \hat{L}_0, \quad v(\tau + i) \in \hat{L}_1 \quad \text{for all } \tau \in [-1, 1] \\ v(-1 + it) = c_{-1} \in \hat{L}_0 \cap \hat{L}_1, \\ v(1 + it) = c_1 \in L_0 \cap \hat{L}_1 \quad \text{for all } t \in [0, 1]. \end{aligned} \tag{26}$$

By Lemma 3 we conclude

$$\int u^* \omega \leq \varepsilon + \alpha(c_1) - \alpha(c_{-1}) \tag{27}$$

Since the set of intersection points in $\hat{L}_0 \cap \hat{L}_1$ is compact and α is continuous we can bound the right hand side of (27) by some constant α independent of $u \in \Omega_j(\hat{L}_0, \hat{L}_1)$. Using now Proposition 1 and Proposition 2 we are done. \square

We also note again that for every $u \in \Omega_j(\hat{L}_0, \hat{L}_1)$ the restriction $t \rightarrow u(\tau + it)$ belongs to $\Sigma_0(\hat{L}_1, \hat{L}_2)$.

V. PROOF OF THEOREM 3 ASSUMING THEOREM 2

By Theorem 2 the space $\Omega_j := \Omega_j(\hat{L}_0, \hat{L}_1)$ is compact in $\Omega := \Omega(\hat{L}_0, \hat{L}_1)$. Moreover Ω_j is invariant under the continuous \mathbb{R} -action

$$\mathbb{R} \times \Omega_j \rightarrow \Omega_j: (\tau, u) \rightarrow u * \tau, \quad (u * \tau)(x) = u(x - \tau)$$

LEMMA 4. — *There exists a continuous map $\sigma: \Omega_j \rightarrow \mathbb{R}$ such that $\tau \rightarrow \sigma(u * \tau)$ is strictly decreasing if u is not a fixed point for the \mathbb{R} -action. Moreover the fixed points for the action are precisely the constant curves in $\hat{L}_0 \cap \hat{L}_1$.*

Proof. — We introduce a restriction map $r: \Omega_j \rightarrow \Sigma_0$ where Σ_0 has been defined in IV before Lemma 3 by

$$r(u)(t) = u(it)$$

Now define $\sigma: \Omega_j \rightarrow \mathbb{R}$ by

$$\sigma(u) = \alpha \circ r(u)$$

where α has been introduced in Lemma 3. By Lemma 3 we have (taking orientation into account)

$$\begin{aligned} & \sigma(u * \tau) - \sigma(u) \\ &= \alpha(u(-\tau + i.)) - \alpha(u(i.)) \quad (1) \\ &= - \int_{[-\tau, 0] + i[0, 1]} u^* \omega = - \int_{[-\tau, 0] + i[0, 1]} (|u_s|^2 + |u_t|^2) ds dt \end{aligned}$$

Now, in order to show that $\tau \rightarrow \alpha(u * \tau)$ is strictly decreasing if u is not a fixed point for the \mathbb{R} -action we have to show that

$$\int_U (|u_s|^2 + |u_t|^2) ds dt > 0$$

for every open subset U of Z . For this we shall use a unique continuation result. So let U be given and $s_0 + it_0$ an interior point. Taking a chart $\varphi: V \rightarrow \mathbb{C}^n$ around $u(s_0 + it_0)$ we see that with $\tilde{J}(x) = T\varphi(u(x))J(u(x))T\varphi(u(x))^{-1}$ and $w = \varphi \circ u$ we have

$$w_s + \tilde{J}(x)w_t = 0 \quad (2)$$

Differentiating this with respect to s and t and using $J(x)^2 = -\text{Id}$ we obtain

$$w_{ss} + w_{tt} + A w_s + B w_t = 0 \quad (3)$$

for some matrix valued smooth mappings A, B . We may assume that $w(x_0) = 0$ where $x_0 = s_0 + it_0$. By Aronszajn's unique continuation result, see [4] and also [28], w vanishes if it vanishes near x_0 . Hence

$$\int_U (|u_s|^2 + |u_t|^2) ds dt > 0$$

as required.

Clearly the constants in $\hat{L}_0 \cap \hat{L}_1$ are fixed points for the \mathbb{R} -action on Ω_j . Now assume $u * \mathbb{R} = \{u\}$ for some $u \in \Omega_j$. Then

$$0 = \sigma(u * \tau) - \sigma(u * (-\tau)) = - \int_{[-\tau, \tau] + i[0, 1]} u^* \omega$$

$$= \frac{1}{2} \int_{[-\tau, \tau] + i[0, 1]} (|u_s|^2 + |u_t|^2) ds dt$$

for every $\tau > 0$. This implies $u = \text{const}$. Since $u(o) \in \hat{L}_0$, $u(i) \in \hat{L}_1$ we see that $u \in \hat{L}_0 \cap \hat{L}_1$ as required. \square

Proof of Theorem 3. — The proof follows along the line of standard Luisternik-Schnirelman-Theory, however carried out for a gradient like \mathbb{R} -action in a compact topological space, as for example done in [10]. The proof will be completed if we can show that the \mathbb{R} -action $*$ on Ω_j has at least $c(\hat{L}_0)$ rest points.

Given any subset K of Ω_j denote by $\varepsilon_K: K \rightarrow (\hat{L}_0, x_0)$ the map $\varepsilon_K(u) = u(o)$ where x_0 is an arbitrarily fixed point in \hat{L}_0 . We obtain an induced map $\tilde{\varepsilon}_K: \check{H}(\hat{L}_0, x_0) \rightarrow \check{H}(K)$. We define a map $\text{ind}: 2^{\Omega_j} \rightarrow \mathbb{N}$ by $\text{ind}(K) = k$ where k is the least integer such that there exist open subset U_1, \dots, U_k of Ω_j covering K such that $\varepsilon_{U_i} = 0$. Since \hat{L}_0 is a compact manifold it is clear that $\text{ind}(\Omega_j) < \infty$. The following properties follow trivially from the definition of ind .

(continuity) every subset K has an open neighborhood U
such that $\text{ind}(U) = \text{ind}(K)$

(monotonicity) if $K_1 \supset K_2$ then $\text{ind}(K_1) \geq \text{ind}(K_2)$

(subadditivity) $\text{ind}(K_1 \cup K_2) \leq \text{ind}(K_1) + \text{ind}(K_2)$ (4)

(invariance) $\text{ind}(K * \tau) = \text{ind}(K)$ for all $\tau \in \mathbb{R}$

(normalisation) $\text{ind}(\text{point}) = 1$

Using the standard properties of cup products and the fact that $\tilde{\tau}: \check{H}(\hat{L}_0) \rightarrow \check{H}(\Omega_j)$ is injective one easily verifies that

$$\text{ind}(\Omega_j) \geq c(\hat{L}_0)$$

Next we define for $i = 1, \dots, \text{ind}(\Omega_j)$

$$d_i = \inf_{K \subset \Omega_j, \text{ind}(K) \geq i} \sup \sigma(K) \tag{5}$$

Clearly

$$-\infty < d_1 \leq d_2 \leq \dots \leq d_{\text{ind}(\Omega_j)} < +\infty \quad (6)$$

Since Ω_j is compact and $\tau \rightarrow \sigma(u * \tau)$ is strictly decreasing if u is not a fixed point for $*$ we see that for given open neighborhood U of $\text{Cr}(d) = \{u \in \Omega_j \mid \sigma(u) = d, u * \mathbb{R} = \{u\}\}$ there exists an $\varepsilon > 0$ such that

$$(\sigma^{-1}((-\infty, d + \varepsilon]) \setminus U) * 1 \subset \sigma^{-1}((-\infty, d - \varepsilon]) \quad (7)$$

Now using (4) and (7) one easily shows that $\text{Cr}(d_j) \neq \emptyset$ if $j \in \{1, \dots, \text{ind}(\Omega_j)\}$ and that if $d_j = d_{j+1}$ the set $\text{Cr}(d_j)$ contains infinitely many points by showing that $\text{ind}(\text{Cr}(d_j)) \geq 2$. In any case this implies the existence of at least $\text{ind}(\Omega_j)$ many rest points for $*$ or equivalently the existence of $\text{ind}(\Omega_j)$ many intersection points in $\hat{L}_0 \cap \hat{L}_1$. Since $\text{ind}(\Omega_j) \geq c(\hat{L}_0)$ the proof of Theorem 3 is complete.

IV. FREDHOLM THEORY AND THE PROOF OF THEOREM 1

Let (M, ω) , J , $g = \omega \circ (\text{Id} \times J)$ and $x \rightarrow L_x$ as described in Theorem 1. Denote by $H: \partial G \times [0, 1] \times M \rightarrow \mathbb{R}$ a Hamiltonian generating the family $x \rightarrow \Phi_x$ of exact symplectic diffeomorphism such that $L_x = \Phi(x, 1, L)$ for some fixed L with $\pi_2(M, L) = 0$. We can extend H to a smooth map $G \times [0, 1] \times M \rightarrow \mathbb{R}$ which we denote again by H . By $\Phi: G \times [0, 1] \times M \rightarrow M$ we denote the associated family of symplectic diffeomorphism. For $j \geq 2$ denote by $\tilde{\Lambda}^j = H^j(G, M)$ the Hilbert manifold of H^j -maps of G into M . Since we assume $(M, g) \subset (\mathbb{R}^N, \langle \cdot, \cdot \rangle)$ one can consider $\tilde{\Lambda}^j = H^j(G, M)$ as a split submanifold of $H^j(G, \mathbb{R}^N)$ (see [13], [35]-[36] for the theory of Hilbert manifolds). For $l = 0, \dots, j$ we denote by $\tilde{E}^l \rightarrow \tilde{\Lambda}^j$ the Hilbert space bundle of H^l -section along H^j -maps, see [13]. By Λ^j we denote the submanifold of $\tilde{\Lambda}^j$ consisting of all $u: G \rightarrow M$ such that $u(\partial G) \subset L$. Observe that for $j \geq 2$ a map $u \in H^j(G, \mathbb{R}^N)$ has a continuous trace on ∂G . We denote by $E^l \rightarrow \Lambda^j$ the pull back of $\tilde{E}^l \rightarrow \tilde{\Lambda}^j$ via the inclusion $\Lambda^j \rightarrow \tilde{\Lambda}^j$. The Sobolev norm $\|\cdot\|_m$ on $H^m(G, \mathbb{R}^N)$ given by the inner product

$$(\xi, \eta)_m = \int_G \langle \xi, \eta \rangle ds dt + \int_G \left(\sum_{|\alpha|=m} \langle D^\alpha \xi, D^\alpha \eta \rangle \right) ds dt$$

induces smooth fibre metrics for the bundles $\tilde{E}^l \rightarrow \tilde{\Lambda}^j$ and $E^l \rightarrow \Lambda^j$ for $l=0, \dots, j$. By a result of Kuiper, see [6] and [32] the group of invertible operators in an infinite dimensional Hilbertspace is contractible. Hence every infinite dimensional Hilbertspace bundle with fibre metric over a Banach manifold admitting a smooth partition of unity is (smoothly) isometric isomorph to a trivial Hilbertspace bundle over the same Banach manifold, where the latter bundle is equipped with the obvious constant fibre metric.

We define a smooth 1-parameter family of diffeomorphisms $(\tau_a)_{a \in [0, 1]}: \tilde{\Lambda}^j \rightarrow \tilde{\Lambda}^j$ by

$$(\tau_a(u))(x) = \Phi(x, a, u(x)) \tag{1}$$

Then $\tau_0(u) = u$, and $\tau_a(u)(x) \in L_x^a = \Phi(x, a, L)$ for $x \in \partial G$ if $u \in \Lambda^j$. Now consider the smooth composite map

$$f: [0, 1] \times \Lambda^j \rightarrow H \tag{2}$$

defined by

$$f(a, u) = \text{pr}_2 \circ \Theta \circ \tilde{\partial} \circ \tau_a(u) \tag{3}$$

where $\Theta: \tilde{E}^{j-1} \simeq \tilde{\Lambda}^j \times H$ is an isometric trivialisaton (Kuiper) and pr_2 is the projection onto the second factor.

PROPOSITION 5. — *If $((a_k, u_k)) \subset [0, 1] \times \Lambda^j$ and $f(a_k, u_k) \rightarrow 0$ in H then $((a_k, u_k))$ is precompact.*

Proof. — If $f(a_k, u_k) \rightarrow 0$ in H then

$$\|\tilde{\partial} \tau_{a_k}(u_k)\|_{j-1, G} \rightarrow 0 \text{ as } k \rightarrow \infty$$

We have to show that every subsequence of (a_k, u_k) has a convergent subsequence. Arguing indirectly we may assume without loss of generality that the given sequence $((a_k, u_k))$ has no convergent subsequence but $a_k \rightarrow a$ for some a . Since $\tau_{a_k}(u_k) \in L_x^{a_k} = \Phi(x, a_k, L)$ for $x \in \partial G$ we can now employ Proposition 4 as follows: Define $H_k: \partial G \times [0, 1] \times M \rightarrow \mathbb{R}$ by $H_k(x, t, m) = a_k H(x, a_k t, m)$. Then $L_x^{a_k} = \Phi_k(x, 1, L)$ where Φ_k is associated to H_k . Clearly $H_k \rightarrow H_0$, defined by $H_0(x, t, m) = a H(x, at, m)$. Hence $\tau_{a_k}(u_k)$ is precompact in $H^j(G, \mathbb{R}^N)$. Hence $(u_k = \tau_{a_k}^{-1}(\tau_{a_k}(u_k)))$ has a convergent subsequence giving a contradiction. \square

Now let ∇ be a Hermitian connection on M , i. e. $\nabla \omega = 0, \nabla g = 0$ and $\nabla J = 0$. Following [13] ∇ induces a connection denoted by the same symbol

in the obvious way for the bundles $E^l \rightarrow \Lambda^j$ and $\tilde{E}^l \rightarrow \tilde{\Lambda}^j$. The covariant derivative $\nabla \partial$ of the section $\bar{\partial}$ of $\tilde{E}^{j-1} \rightarrow \tilde{\Lambda}^j$ satisfies for $\xi \in T_u \tilde{\Lambda}^j$

$$\nabla_{\xi} \bar{\partial}(u) = \nabla_s \xi + J(u) \nabla_t \xi + Z_u(\xi) \quad (4)$$

where Z_u is coming from the torsion of ∇ .

PROPOSITION 6. — *There exist an open neighborhood \tilde{U} in $[0, 1] \times \Lambda^j$ of the set $f^{-1}(0)$ such that $f|_U: U \rightarrow H$ is a nonlinear Fredholm operator of index $n+1$, where U is the component of \tilde{U} containing the set of all (o, u) satisfying $f(o, u) = 0$. Moreover U can be chosen in such a way that f is proper with respect to a small open neighborhood of $0 \in H$.*

Proof. — Let $(a, u) \in [0, 1] \times \Lambda^j$ such that $f(a, u) = 0$. One easily computes that $T_u f(a, u): T_u \Lambda^j \rightarrow H$ is given by

$$T_u f(a, u) \xi = \text{pr}_2 \circ \Theta \circ [\nabla_s (T \tau_a(u) \xi) + J(\tau_a(u)) \nabla_t (T \tau_a(u) \xi)] + K_a(u) \xi \quad (5)$$

where $K_a(u)$ is relatively compact.

Let us show that this is a Fredholm operator of index n . Since $\text{pr}_2 \circ \Theta$ gives an isomorphism $\tilde{E}_u^{j-1} \rightarrow H$ we have to show that the map $\xi \rightarrow \nabla_s (T \tau_a(u) \xi) + J(\tau_a(u)) \nabla_t (T \tau_a(u) \xi)$ is a Fredholm operator. First observe that $T_u \Lambda^j$ consists of all H^j sections of $u^* TM \rightarrow G$ such that $\xi(x) \in T_{u(x)} L$ for $x \in \partial G$. $T \tau_a(u)$ maps this space isomorphically onto the space of all H^j sections such that $\xi(x) \in T_{\tau_a(u)(x)} L_x^a$ for $x \in \partial G$. Now using Lemma 1 similarly as in the proof of Proposition 1 (but much easier) we find for given $u \in \Lambda^j$ numbers $c_1, c_2 > 0$ such that

$$\begin{aligned} \|\nabla_s \xi + J(\tau_a(u)) \nabla_t \xi\|_{j-1, G} &\geq c_1 \|\xi\|_{j, G} - c_2 \|\xi\|_{j-1, G} \\ &\text{for all } \xi \in H^j(G, \mathbb{R}^N) \text{ with } \xi(x) \in T_{\tau_a(u)(x)} L_x^a \text{ for all } x \in \partial G. \end{aligned} \quad (6)$$

This shows that the operator in (6) is semi-Fredholm.

In order to show that the operator in (6) is Fredholm we shall use Kato's perturbation theorem for semi-Fredholm operators [29]. Let $a=0$ and $u \in \Lambda^j$ such that $f(a, u) = 0$. Then $u = \text{const.} \in L$

$$\left[\text{since } \pi_2(M, L) = 0 \Rightarrow 0 = \int_G u^* \omega = \frac{1}{2} \int_G (|u_s|^2 + |u_t|^2) ds dt \right].$$

For such a u we have

$$\nabla_s \xi + J(u) \nabla_t \xi = \frac{\partial}{\partial s} \xi + J(u) \frac{\partial}{\partial t} \xi \quad (7)$$

where $\xi(x) \in T_c M$ for $x \in G$ and $\xi(x) \in T_c L$ for $x \in \partial G$, where $c = u(x)$. By a result in [47] this is a Fredholm operator of index n in the Hölder space setting. In the Sobolev space setting we will have by regularity consideration of course the same index. If now u belongs to the component of the constant maps in Λ^j and $a \in [0, 1]$ then we can connect u and a constant map by a continuous path. By Kato's perturbation result (6) defines a Fredholm operator of index n if u is homotopic to a constant map. (Kato: If in a continuous family of semi-Fredholm maps at least one is Fredholm than all the others are Fredholm.) Since the set of linear Fredholm operators is open we can find the set U with the required properties. We have to show that perhaps replacing U by a smaller set having the same properties than U the preimage of any compact set K in a sufficiently small ε -ball around $o \in H$ is compact in U . This follows however immediately from Proposition 5 and the local normal forms for nonlinear Fredholm operators as for example given in [7]. \square

LEMMA 5. — *Let $f: U \rightarrow H$ be as in Proposition 5. Then $f_a: U_a = \{u \in \Lambda^j \mid (a, u) \in U\} \rightarrow H$ is a proper Fredholm operator of index n and if $\pi: U \rightarrow L$ is the map defined by $\pi(u) = u(x_0)$ for some $x_0 \in \partial G$, then the map $\tilde{f}_a: U_a \rightarrow L \times H: \tilde{f}_a(u) = (\pi(u), f_a(u))$ is a proper Fredholm operator of index 0 and the \mathbb{Z}_2 -degree of \tilde{f}_a with respect to $l_0 \times \{o\}$ for some $l_0 \in L$ is given by*

$$\deg_{\mathbb{Z}_2}(\tilde{f}_a, U_a, l_0 \times \{o\}) = 1 \tag{8}$$

Proof. — By Proposition 6 and the homotopy invariance of the \mathbb{Z}_2 -degree we have

$$\deg_{\mathbb{Z}_2}(\tilde{f}_a, U_a, l_0 \times \{o\}) = \deg(\tilde{f}_0, U_0, l_0 \times \{o\}) \tag{9}$$

Now, if $f_0(u) = l_0 \times \{o\}$ we have

$$\left. \begin{aligned} u(x_0) &= l_0 \\ \bar{\partial}u &= o \text{ on } G \setminus \partial G \text{ and } u(x) \in L \text{ for } x \in \partial G \end{aligned} \right\} \tag{10}$$

Since $\pi_2(M, L) = 0$ (10) implies that $u(x) = l_0$ for all $x \in G$. If we can show that $T_u \tilde{f}_0: T_u \Lambda^j \rightarrow T_{\tilde{f}_0(u)}(L \times H)$ is an isomorphism we are done. We have

$$(T_u \tilde{f}_0) \xi = \xi(x_0), (T_u f_0) \xi \tag{11}$$

Since $T_u f_0$ has index n and the kernel are precisely the constant sections ξ we see that $T_u \tilde{f}_0$ is onto. Since the map $\xi \rightarrow \xi(x_0)$ maps the constant

section (a n -dimensional space) onto $T_{l_0}L$ we see that $T_u\tilde{f}_0$ is an isomorphism. Hence

$$\deg_{Z_2}(\tilde{f}_0, U_0, l_0 \times \{o\}) = 1 \quad (12)$$

Combining (9) and (12) gives the desired result (8). \square

Assume now that we can show that π induces an injection $\tilde{\pi}: \check{H}(L) \rightarrow \check{H}(f(1, \cdot)^{-1}(0))$. From the commutative diagram

$$\begin{array}{ccc} f(1, \cdot)^{-1}(0) & \xrightarrow{\pi} & L \\ \tau_1(\cdot) \downarrow \int & & \uparrow \int \tau_1(\cdot)^{-1} \\ \Omega_{G, [x \rightarrow L_x], J} & \xrightarrow{\pi_{x_0}} & L_{x_0} \end{array}$$

we infer that that $\tilde{\pi}_{x_0}$ is injective which will complete the proof of Theorem 1. [Note that for fixed $j \geq 2f(1, \cdot)^{-1}(0) \simeq \Omega_{G, [x \rightarrow L_x], J}$ via $\tau_1(\cdot)$ and that by elliptic regularity theory the solution of $f(1, u) = 0$ i.e. the solution of $\bar{\partial}(\tau_1(u)) = 0$ are smooth.]

That $\tilde{\pi}$ is injective will follow from a completely abstract result which we shall prove now. Before we do so let us sum up what we know.

We have a smooth Fredholm operator $\psi := f_1$ defined on a separable Hilbert manifold $V := U_1$ with image in a separable Hilbert space H such that $\psi: V \rightarrow H$ is proper with respect to a neighborhood of o in H . Moreover ψ has index n . We have a compact smooth manifold L and a smooth map $\pi: V \rightarrow L$ such that

$$\deg_{Z_2}(\tilde{\psi}, V, l_0 \times \{o\}) = 1$$

for some $l_0 \in L$ where $\tilde{\psi}: V \rightarrow L \times H$ is defined by $\tilde{\psi}(u) = (\pi(u), \psi(u))$. We wish to conclude that $\tilde{\pi}: \check{H}(L) \rightarrow \check{H}(\tilde{\psi}^{-1}(o))$ is injective. That this is in fact true is the statement of the following Theorem, whose proof uses some duality theory and implicitly the cohomology transfer (see [12]).

THEOREM 5. — *Let $\psi: V \rightarrow H$ be a smooth Fredholm operator of index n defined on a separable Hilbert manifold V with image in a separable Hilbert space H . Assume ψ is proper with respect to a zero neighborhood in H . Suppose there exists a smooth map $\pi: V \rightarrow L$ into a compact smooth manifold L such that*

$$\deg_{Z_2}(\tilde{\psi}, V, l_0 \times \{o\}) = 1$$

for some $l_0 \in L$ where $\tilde{\Psi}(u) = (\pi(u), \psi(u))$. Then $\tilde{\pi}: \check{H}(L) \rightarrow \check{H}(\psi^{-1}(o))$ is injective.

Proof. — We find an open neighborhood W of $K := \psi^{-1}(o)$ in V and an orthogonal projection $P: H \rightarrow H$ with $\text{codim } R(P) < \infty$ such that

$$PT\psi(u): T_u V \rightarrow PH$$

is surjective for every $u \in W$. (Here of course we use that K is compact.) Define

$$A := \{u \in W \mid P\psi(u) = 0\}$$

Then A is a submanifold of V of dimension

$$d = \text{ind}(\psi) + \text{codim } R(P) = n + \text{codim } R(P)$$

By the very definition of the \mathbb{Z}_2 -degree we have for the induced map

$$\tilde{\Psi}: M \rightarrow L \times (I - P)H = L \times \mathbb{R}^m$$

the equality

$$1 = \text{deg}(\tilde{\Psi}, V, l_0 \times \{o\}) = \text{deg}(\tilde{\Psi}, M, l_0 \times \{o\})$$

Now using the homological definition of the \mathbb{Z}_2 -degree we see that (coefficients of H_* are in \mathbb{Z}_2).

$$\tilde{\Psi}_*: H_d(M, M \setminus \tilde{\Psi}^{-1}(l_0 \times \{o\})) \rightarrow H_d(L \times \mathbb{R}^m, (L \times \mathbb{R}^m) \setminus \{(l_0, 0)\})$$

maps the fundamental class $0_{\tilde{\Psi}^{-1}(l_0, o)}$ to the fundamental class $o_{(l_0, o)}$. Hence the map

$$\tilde{\Psi}: (M, M \setminus \tilde{\Psi}^{-1}(L \times \{0\})) \rightarrow (L \times \mathbb{R}^m, L \times (\mathbb{R}^m \setminus \{o\}))$$

induces in d -dimensional \mathbb{Z}_2 -homology a map which maps the fundamental class $o_{\tilde{\Psi}^{-1}(L \times \{o\})}$ to the fundamental class $o_{L \times \{o\}}$. To simplify notation we shall write \tilde{o} for $o_{\tilde{\Psi}^{-1}(L \times \{o\})}$ and o for $o_{L \times \{o\}}$. We have the sequence

$$\begin{array}{ccccccc}
 \check{H}^i(L \times \{o\}) & \xrightarrow{\tilde{\Psi}} & \check{H}^i(K) & \xrightarrow[\text{duality}]{\cap \tilde{o}} & H_{d-i}(M, M \setminus K) & \xrightarrow{\tilde{\Psi}_*} & H_{d-i}(L \times \mathbb{R}^m, L \times \mathbb{R}^m \setminus \{o\}) \\
 & & & & \circ & & \downarrow \int (\cap o)^{-1} \\
 & & & & & & \check{H}^i(L \times \{o\})
 \end{array} \tag{13}$$

The composite map Θ defines a group homomorphism. We compute Θ as follows: Let $\varepsilon \in \check{H}^i(L \times \{o\})$, then

$$\begin{aligned}\Theta(\varepsilon) &= (\cap o)^{-1} \check{\Psi}_*(\check{\Psi}(\varepsilon) \cap \check{o}) \\ &= (\cap o)^{-1} (\varepsilon \cap \check{\Psi}_*(\check{o})) \\ &\text{(naturality of } \cap\text{-products)} \\ &= (\cap o)^{-1} (\varepsilon \cap o) \\ &= \varepsilon\end{aligned}$$

So $\Theta = \text{Id}$. Denote the map $\check{H}^i(K) \rightarrow \check{H}^i(L \times \{o\})$ defined by diagram (13) by α . Then

$$\alpha \circ \check{\Psi} = \Theta = \text{Id} \quad (14)$$

We have the commutative diagram

$$\begin{array}{ccccc}\check{H}(L \times \{o\}) & \xrightarrow{\check{\Psi}} & \check{H}(K) & \xrightarrow{\alpha} & \check{H}(L \times \{o\}) \\ \uparrow \text{pr}_1 & & \nearrow (\pi|K) & & \\ \check{H}(L) & & & & \end{array}$$

Hence $(\pi|K)$ must be injective as required. \square

REFERENCES

- [1] R. ABRAHAM and J. MARSDEN, *Foundations of Mechanics*, Benjamin, Cummings Reading, Mass., 1978.
- [2] S. AGMON, A. DOUGLIS and L. NIRENBERG, Estimates Near the Boundary for Solutions of Elliptic Partial Differential Equations Satisfying General Boundary Conditions I, II, *Comm. Pure Appl. Math.*, Vol. 12, 1959, pp. 623-727 and Vol. 17, 1964, pp. 35-92.
- [3] V. I. ARNOLD, Sur une propriété topologique des applications canoniques de la mécanique classique, *C.R. Acad. Sci. Paris*, T. 261, 1965, pp. 3719-249.
- [4] N. ARONSZAJN, A Unique Continuation Theorem for Solutions of Elliptic Partial Differential Equations or Inequalities of the Second Order, *J. Math. Pures Appl.*, (9), Vol. 36, 1957, pp. 235-249.
- [5] D. BENNEQUIN, Problèmes elliptiques, surfaces de Riemann et structures symplectiques, *Séminaire Bourbaki*, 38^e année, 1985-1986, No 657.

- [6] B. BOOS and D. D. BLEEKER, *Topology and Analysis*, Universitext, Springer, 1985.
- [7] Y. BORISOVICH, V. ZVYAGIN and V. SAPRONOV, Nonlinear Fredholm maps and Leray Schauder Theory, *Russian Math. Survey's*, Vol. **32**, No. 4, 1977, pp. 1-54.
- [8] M. CHAPERON, Quelques questions de géométrie symplectique, *Séminaire Bourbaki* 1982/1983, *Asterisque*, No. **105-106**, pp. 231-249.
- [9] D. C. CLARK, A Variant of Lusternik-Schnirelman-Theory, *Indiana University Math. J.*, Vol. **22**, No. 1, 1972, pp. 65-74.
- [10] C. CONLEY and E. ZEHNDER, The Birkhoff-Lewis Fixed Point Theorem and a Conjecture of V. I. Arnold, *Inv. Math.*, T. **73**, 1983, pp. 33-49.
- [11] C. CONLEY and E. ZEHNDER, Morse Type Index Theory for Flows and Periodic Solutions for Hamiltonian Equations, *Comm. Pure and Appl. Math.*, Vol. **27**, 1984, pp. 211-253.
- [12] A. DOLD, Lectures on Algebraic Topology, *Grundlehren der Math. Wissenschaften*, Vol. 200, Springer, 2nd edition.
- [13] H. ELIASSON, Geometry of Manifold of Maps, *J. Diff. Geometry*, **1**, 1967, pp. 165-194.
- [14] D. FREED and V. UHLENBECK, *Instantons and Four-Manifolds*, Springer, 1984.
- [15] A. FLOER, *The Unregularized Gradient Flow of the Symplectic Action* (preprint).
- [16] A. FLOER, *A Morse Theory for Lagrangian Intersections* (preprint).
- [17] A. FLOER, *A Relative Morse Index for the Symplectic Action* (preprint).
- [18] A. FLOER, Proof of the Arnold Conjecture for Surfaces and Generalisations for Certain Kahler Manifolds, *Duke Math. J.*, Vol. **51**, 1986, pp. 1-32.
- [19] A. FLOER, H. HOFER and C. VITERBO, *The Weinstein Conjecture in $P \times C^1$* (to appear).
- [20] B. FORTUNE and A. WEINSTEIN, A Symplectic Fixed Point Theorem for Complex Projective Spaces, *Bull. A.M.S.*, Vol. **12**, 1985.
- [21] B. FORTUNE, A Symplectic Fixed Point Theorem for CP^n , *Inv. Math.*, Vol. **81** (Fax 1), 1985, pp. 29-46.
- [22] M. GROMOV, Pseudo-Holomorphic Curves in Symplectic Manifolds, *Inv. Math.*, Vol. **82**, 1985, pp. 307-347.
- [23] M. GROMOV and V. A. ROHLIN, Imbeddings and Immersions in Riemannian Geometry, *Russ. Math. Surveys*, Vol. **25**, 1970, p. 1-57.
- [24] H. HOFER, Lagrangian Embeddings and Critical Point Theory, *Ann. I.H.P.*, *Analyse non linéaire*, Vol. **2**, 1985, pp. 407-462.
- [25] H. HOFER and C. VITERBO, *The Weinstein Conjecture in Cotangent Bundles and Related Results* (to appear).
- [26] H. HOFER and E. ZEHNDER, Periodic Solutions on Hypersurfaces and a Result by C. Viterbo, *Inv. Math.*, Vol. **90**, 1987, pp. 1-9.
- [27] I. EKELAND and H. HOFER, *Two Symplectic Fixed Point Theorems* (submitted).
- [28] L. HORMANDER, *The Analysis of Linear Differential Operators III*, Springer, 1985.
- [29] T. KATO, *Perturbation Theory for Linear Operators*, Springer, 1976.
- [30] W. KLINGENBERG, Riemannian geometry, *de Gruyter studies in Math.*, Vol. **1**, Walter de Gruyter, 1982.
- [31] W. KLINGENBERG, *Lectures on Closed Geodesics*, Springer, 1978.
- [32] N. KUIPER, The Homotopy Type of the Unitary Groups of Hilbert Spaces, *Topology*, Vol. **3**, 1965, pp. 19-30.
- [33] F. LAUDENBACH and J. C. SIKORAV, Persistence d'intersections avec la section nulle., *Inv. Math.*, Vol. **82**, 1985, pp. 349-357.
- [34] D. MCDUFF, Examples of Symplectic Structures, *Inv. Math.*, Vol. **89**, 1987, pp. 13-36.
- [35] R. PALAIS, Morse Theory on Hilbert Manifolds, *Topology*, Vol. **2**, 1963, pp. 299-340.
- [36] R. PALAIS, *Foundations of Global Non-Linear Analysis*, Benjamin, 1968.
- [37] B. PANSU, Notes sur les pages 316 à 323 de l'article de M. Gromov *Pseudoholomorphic Curves in Symplectic Manifolds* (preprint).
- [38] J. SACKS and V. UHLENBECK, The Existence of Minimal Immersions of Two Spheres, *Ann. Math.*, Vol. **113**, 1981, pp. 1-24.

- [39] J. C. SIKORAV, Points fixes d'une application symplectique homologue à l'identité, *J. Diff. Geom.*, Vol. **22**, 1985, pp. 49-79.
- [40] S. SMALE, An Infinite-Dimensional Version of Sard's Theorem, *Amer. J. Math.*, Vol. **87**, 1965, pp. 861-866.
- [41] I. N. VEKUA, *Generalized Analytic Functions*, Pergamon, 1962.
- [42] C. VITERBO, A Proof of the Weinstein Conjecture in \mathbb{R}^{2n} , *Ann. I.H.P., Analyse non linéaire*, 1987 (à paraître).
- [43] W. WARSCHAWSKI, On Differentiability at the Boundary in Conformal Mapping, *Proc. A.M.S.*, Vol. **12**, 1961, pp. 614-620.
- [44] A. WEINSTEIN, Lagrangian Submanifolds and Hamiltonian Systems, *Ann. Math.*, Vol. **98**, 1973, pp. 337-410.
- [45] A. WEINSTEIN, C^0 -Perturbation Theorems for Symplectic Fixed Points and Lagrangian Intersections, *Séminaire sud-rhodanien de géométrie III*, Travaux en cours, Hermann, Paris, 1984, pp. 140-144.
- [46] A. WEINSTEIN, Symplectic Geometry and the Calculus of Variations, *Marston Morse Memorial Lectures*, I.A.S., Princeton, 1985 (to appear).
- [47] W. L. WENDLAND, *Elliptic Systems in the Plane*, Pitman, 1979.
- [48] J. G. WOLFSON, *A PDE Proof of Gromov's Compactness of Pseudo Holomorphic Curves*, preprint, 1986.
- [49] E. ZEHNDER, *Some Perspectives in Hamiltonian Systems*, preprint.
- [50] A. FLOER, *Cuplength-Estimates on Lagrangian Intersections*, preprint.

(Manuscrit reçu le 15 novembre 1987.)