

Minimal models for actions of amenable groups

Bartosz Frej and Dawid Huczek¹

Abstract. We prove that on a metrizable, compact, zero-dimensional space every free action of an amenable group is measurably isomorphic to a minimal G -action with the same, i.e. affinely homeomorphic, simplex of measures.

Mathematics Subject Classification (2010). 28D15, 37A15, 37B05.

Keywords. Topological model, dynamical system, group action, amenable group, invariant measure, Choquet simplex, Borel isomorphism.

1. Introduction

1.1. Background. The study has origins in the famous Jewett–Krieger theorem: to any ergodic and invertible measure-preserving map there exists an isomorphic strictly ergodic (i.e. uniquely ergodic and minimal) homeomorphism. Natural further investigation concerns more precise modelling, in which given a topological dynamical system one searches for the minimal system with the same measure dynamics, i.e. having identical simplex of invariant measures with corresponding measure preserving actions being isomorphic. The adequate theorem, valid on zero-dimensional spaces even for a non-invertible map, was proved by Downarowicz in [1]. It is worth mentioning that there is a paper by Kornfeld and Ormes [5], which overlaps with Downarowicz’s results (in particular, the model is found in the same class of orbit equivalence relation for the price of restricting to simplices with countably many extreme points). The next step was made by Frej and Kwaśnicka in [3], where the analogous result for free \mathbb{Z}^d actions was proved. At the present paper we generalize the latter to free actions of arbitrary amenable groups on zero-dimensional spaces.

We should also mention a related earlier result of Furstenberg and Weiss (see [4]), who show (for actions of \mathbb{Z}) that any topologically transitive compact extension of a non-periodic minimal dynamical system has a minimal model with the same measure-theoretic structure.

¹ Research of both authors is supported from resources for science in years 2013-2018 as research project (NCN grant 2013/08/A/ST1/00275, Poland).

1.2. Basic notions. Let G be a countable *amenable group*, i.e. a group in which there exists a sequence of finite sets $F_n \subset G$ (called a *Følner sequence*, or the sequence of Følner sets), such that for any $g \in G$ we have

$$\lim_{n \rightarrow \infty} \frac{|gF_n \Delta F_n|}{|F_n|} = 0,$$

where $gF = \{gf : f \in F\}$, $|\cdot|$ denotes the cardinality of a set, and Δ is the symmetric difference.

Throughout the paper we assume that X is a zero-dimensional, compact metrizable space. The action of G on X is determined by a homomorphism from G to the group all of homeomorphisms of X , but we will avoid introducing unnecessary notation writing gx for the image of x by an appropriate homeomorphism. The action of G is *free* if $gx = x$ for any $g \in G$ and $x \in X$ implies that g is the neutral element of G . The action is *minimal* if for any $x \in X$ the closure of the orbit $\{gx : g \in G\}$ is equal to the whole X , which is equivalent to non-existence of non-trivial closed G -invariant subsets.

A measure μ on X is G -invariant if $\mu(gA) = \mu(A)$ for all $g \in G$. By $\mathcal{P}_G(X)$ we denote the set of all G -invariant Borel probability measures on X . It is well known that in our case $\mathcal{P}_G(X)$ endowed with the weak* topology is a compact, metrizable and convex subset of the space of all Borel probability measures on X . Every point of $\mathcal{P}_G(X)$ has a unique representation as a barycenter of a certain Borel measure concentrated on the Borel set of all ergodic measures. These properties are usually abbreviated by saying that $\mathcal{P}_G(X)$ is a Choquet simplex. A set $E \subset X$ is called *full* if $\mu(E) = 1$ for every $\mu \in \mathcal{P}_G(X)$.

Definition 1.1. We say that two dynamical systems (X, G) and (Y, G) with the same acting group G are *Borel* isomorphic* if there exists an equivariant (i.e. commuting with the action) Borel-measurable bijection $\Phi: \tilde{X} \rightarrow \tilde{Y}$ between full invariant subsets $\tilde{X} \subset X$ and $\tilde{Y} \subset Y$, such that the conjugate map $\Phi^*: \mathcal{P}_G(X) \rightarrow \mathcal{P}_G(Y)$ given by the formula $\Phi^*(\mu) = \mu \circ \Phi^{-1}$ is a (affine) homeomorphism with respect to weak* topologies.

Our main result is the following theorem.

Theorem 1.2. *If X is a metrizable, compact, zero-dimensional space and an amenable group G acts freely on X then (X, G) is Borel* isomorphic to a minimal dynamical system (Y, G) (with Y being also metrizable, compact and zero-dimensional).*

1.3. Positive Banach density vs. syndeticity

Definition 1.3. The set $S \subset G$ is *right-syndetic* (we will briefly write *syndetic*) if there exists a finite set $F \subset G$ such that $SF = G$.

Definition 1.4. For $S \subset G$ and a finite $F \subset G$ denote

$$D_F(S) = \inf_{g \in G} \frac{|S \cap Fg|}{|F|}$$

and

$$D(S) = \sup\{D_F(S) : F \subset G, |F| < \infty\}.$$

We call $D(S)$ the *lower Banach density* of S .

The following properties of the above notions are quite easy to prove.

Proposition 1.5. (1) If (F_n) is a Følner sequence then $D(S) = \lim_{n \rightarrow \infty} D_{F_n}(S)$.

(2) S is syndetic if and only if $D(S) > 0$.

1.4. The array representation of (X, G) . Let d_X denote a metric on X . Let $\Lambda = (X \cup \{0, 1, *\})^{\mathbb{Z}}$, where 0, 1 and * are additional elements which do not initially occur in X . We will regard elements of Λ as bilateral sequences which will have elements of X or 0 on non-negative coordinates and elements $\{0, 1, *\}$ on negative coordinates. We define a compact metric d on $X \cup \{0, 1, *\}$ by

$$d(x, y) = \begin{cases} d_X(x, y) & \text{for } x, y \in X, \\ \text{diam}(X) & \text{if } x \notin X \text{ or } y \notin X \end{cases} \quad (\text{for } x \neq y).$$

We can now define a distance d_Λ between $\mathbf{x} = (\dots, x^{-1}, x^0, x^1, \dots)$ and $\mathbf{y} = (\dots, y^{-1}, y^0, y^1, \dots)$ in Λ by

$$d_\Lambda(\mathbf{x}, \mathbf{y}) = \sum_{i=-\infty}^{\infty} 2^{-|i|} d(x^i, y^i).$$

Note that (Λ, d_Λ) is a compact metric space. The space Λ^G is an analogue of a multidimensional shift space. The action of G on Λ^G is defined by

$$(gy)(h) = y(hg) \quad \text{for every } y \in \Lambda^G.$$

We define an array representation \widehat{X} of X as a range of a map $X \ni x \mapsto \hat{x} \in \Lambda^G$ defined by

$$\hat{x}(g)_n = \begin{cases} gx & \text{if } n = 0, \\ 0 & \text{otherwise.} \end{cases}$$

Levels $n \neq 0$ will be used in the construction of a Borel* isomorphism aforementioned in Theorem 1.2. It is not very hard to verify that \widehat{X} is compact and G -invariant and that $x \mapsto \hat{x}$ is in fact a topological conjugacy between (X, G) and (\widehat{X}, G) .

By a block in Λ^G we mean a map $B: F \rightarrow \Lambda$, where F is a finite subset of G . We define a distance between blocks B_1, B_2 on a common domain F by

$$D(B_1, B_2) = \sup_{g \in F} d_\Lambda(B_1(g), B_2(g))$$

and we set $D(B_1, B_2) = \text{diam}(X)$ if the domains of B_1 and B_2 are two different subsets of G . We say that B' is a *subblock* of B if the domain F of B contains the domain F' of B' and both blocks agree on F' . A block B with the domain F *occurs* in $Z \subset \Lambda^G$ if there is $z \in Z$ and $g \in G$ such that $z(fg) = B(f)$ for every $f \in F$.

Remark 1.6. By Tikhonov’s theorem, the set of all blocks on a fixed domain is a compact space. Moreover, compactness of \widehat{X} implies that the set of all blocks, which occur in \widehat{X} and whose domain is fixed, is compact. It follows that for every $\varepsilon > 0$ it contains a finite ε -dense subset.

1.5. A few useful properties of the Følner sequence. First of all note that in any amenable group there exists a Følner sequence with the following additional properties (see [2]):

- (1) $F_n \subset F_{n+1}$ for all n ,
- (2) $e \in F_n$ for all n (e denotes the neutral element of G),
- (3) $\bigcup_n F_n = G$,
- (4) $F_n = F_n^{-1}$.

Throughout this paper, we will assume that the Følner sequence which we use has these properties.

If F and A are finite subsets of G and $0 < \delta < 1$, we say that F is (A, δ) -invariant if

$$\frac{|F \Delta AF|}{|F|} < \delta,$$

where $AF = \{af : a \in A, f \in F\}$. Observe that if A contains the neutral element of G , then (A, δ) -invariance is equivalent to the simpler condition

$$|AF| < (1 + \delta)|F|.$$

If (F_n) is a Følner sequence, then for every finite $A \subset G$ and every $\delta > 0$ there exists an N such that for $n > N$ the sets F_n are (A, δ) -invariant. This type of invariance has the following consequence:

Lemma 1.7. *Let $F \subset G$ be a finite set. For any ε there exists a δ such that if $H \subset G$ is (F, δ) -invariant then the set $H_F = \{h \in H : Fh \subset H\}$ has cardinality greater than $(1 - \varepsilon)|H|$.*

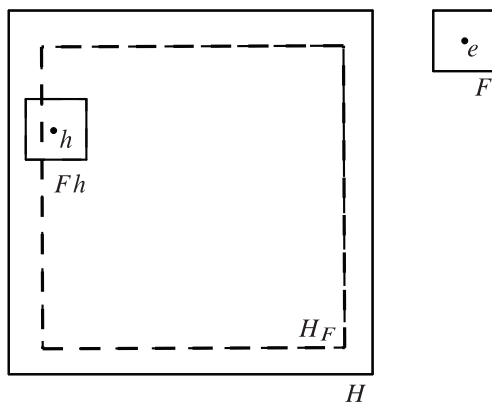

Figure 1. A picture illustrating Lemma 1.7. The set H_F marked with a broken line has cardinality greater than $(1 - \varepsilon)|H|$, where H is a big square marked with a solid line.

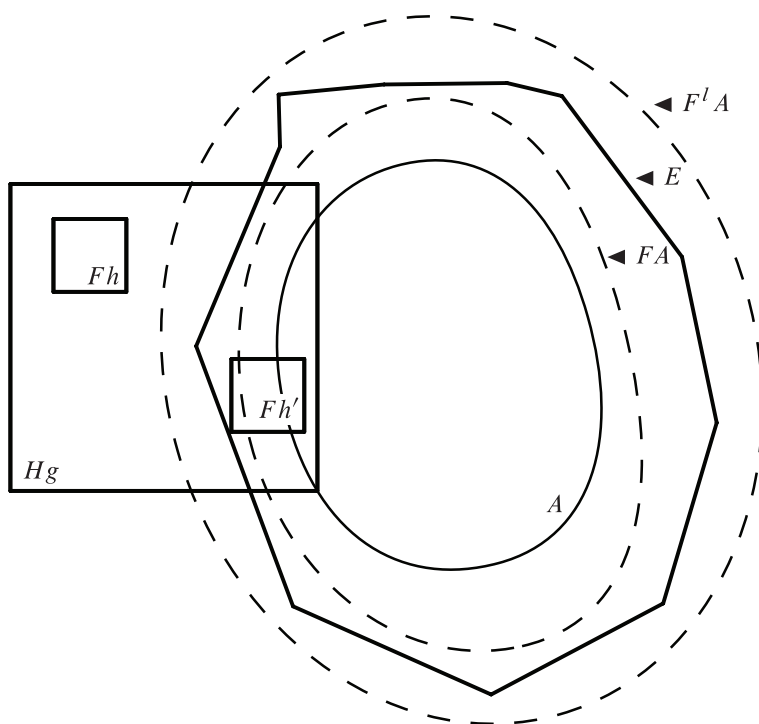

Figure 2. A picture illustrating Lemma 1.8. The smallest elliptic set is A . It is surrounded by FA and $F^l A$ marked by broken lines, between which there is a closed solid line bounding E . The big square is Hg . The two small squares show different positions of a translate of F : $Fh \subset Hg \setminus E$ and $Fh' \subset Hg \cap E$.

Proof. Set $\delta = \frac{\varepsilon}{|F|}$. Observe that if $h \notin H_F$ then for some $f \in F$ we have $fh \in FH \setminus H$. Obviously, for every $g \in FH \setminus H$ the number of elements $h \in H$ such that $fh = g$ for some $f \in F$ is at most $|F|$. Therefore the number of elements $h \in H$ such that $fh \in FH \setminus H$ for some $f \in F$ is at most $|F||FH \setminus H| \leq |F||FH \Delta H| < |F|\delta|H| = \varepsilon|H|$. \square

Lemma 1.8. *Let $F \subset G$ contain the neutral element e . For any l , there exists a set $H \supset F$ such that for every $A \subset G$ and $g \in G$ if $FA \subset E \subset F^l A$ then either $Fh \subset Hg \cap E$ or $Fh \subset Hg \setminus E$ for some $h \in Hg$.*

Intuitively, this can be interpreted as follows: if we divide H in two parts such that the boundary is sufficiently “regular” (which is expressed by the fact that the dividing set E is between FA and $F^l A$), then at least one of the resulting parts is regular enough to contain a translated copy of F .

Proof. Let $H \subset G$ be a Følner set such that its subset

$$D = \{h \in H: F^{-1}Fh \subset H\}$$

has cardinality equal to at least $(1 - \frac{1}{3|F|^{l+1}})|H|$ (Lemma 1.7 is used with $\varepsilon = \frac{1}{3|F|^{l+1}}$). Suppose that the cardinality of $A \cap Hg$ is at least $\frac{1}{3|F|^{l+1}}|H|$. Then $A \cap Dg$ is nonempty, and for $h \in A \cap Dg$ we have $Fh \subset E$ and $Fh \subset Hg$. Otherwise, if the cardinality of $A \cap Hg$ is less than $\frac{1}{3|F|^{l+1}}|H|$, then we will show that $Hg \setminus F^{-1}F^l A$ (and thus also $Hg \setminus E$) has nonempty intersection with Dg . Indeed, observe that if h is in $Hg \cap F^{-1}F^l A$, then $h \in F^{-1}F^l a$ for some $a \in A$. Either $a \in Hg$ (and then $h \in F^{-1}F^l(Hg \cap A)$) or $a \notin Hg$. In the latter case $F^{-1}Fh$ is not contained in Hg , and therefore h cannot be in Dg . Combining these two cases, we see that

$$Hg \cap F^{-1}F^l A \subset (F^{-1}F^l(Hg \cap A)) \cup (Hg \setminus Dg).$$

Both sets on the right have cardinality smaller than $\frac{1}{3}|H|$, therefore

$$|Hg \cap F^{-1}F^l A| < \frac{2}{3}|H|,$$

hence $Hg \setminus F^{-1}F^l A$ is large enough to have nonempty intersection with Dg . If h is in such an intersection, then $Fh \subset Hg$ (since $h \in Dg$) and $Fh \cap F^l A = \emptyset$, since otherwise we would have $h \in F^{-1}F^l A$. \square

Remark 1.9. Note that the set H chosen in the above lemma also satisfies the hypothesis for any subset of F containing the neutral element, since the reasoning above (in particular the choice of the set D) can be repeated unchanged for such subsets.

1.6. Marker lemma

Lemma 1.10 (Marker lemma). *Let X be a compact, metrizable, zero-dimensional space. Let G be a group acting continuously and freely on X . For every finite $H \subset G$ there exists a clopen set V such that*

- (1) $g(V)$ are disjoint for each $g \in H$,
- (2) $\bigcup_{g \in F} g(V) = X$ for some Følner set F .

Proof. Since the action of G is free, for any $x \in X$ the points gx are all different. Therefore there exists a clopen neighborhood $U_x \ni x$ such that the sets $h^{-1}g(U_x)$ are pairwise disjoint for distinct $h^{-1}g$, where $g, h \in H$. The sets $(U_x)_{x \in X}$ cover the compact set X , so we can select from them a finite subcover U_1, \dots, U_M .

Now define the following sets V_1, \dots, V_M :

$$V_1 = U_1 \tag{1}$$

$$V_j = V_{j-1} \cup \left(U_j \setminus \left(\bigcup_{g, h \in H} g^{-1}h(V_{j-1}) \right) \right). \tag{2}$$

Let $V = V_M$. Observe that the sets $g(V), g \in H$ are pairwise disjoint. Indeed, suppose that for some $g, h \in H$ we have $g(V) \cap h(V) \neq \emptyset$. Equivalently, $V \cap h^{-1}g(V) \neq \emptyset$. Therefore there exists an $x \in V$ such that $x \in h^{-1}g(V)$, and thus $g^{-1}hx \in V$. Denote $y = g^{-1}hx$. Let j and j' be the smallest indices for which $x \in V_j$ and $y \in V_{j'}$. Since $x = h^{-1}gy$ (therefore the points x and y are interchangeable), we can assume without loss of generality that $j' \leq j$. As $x \in V_j \setminus V_{j-1}$, x must belong to U_j . The point y is also in V_j , and since it belongs to $g^{-1}h(U_j)$, it cannot belong to U_j . It follows that $y \in V_{j-1}$. In this case $x = h^{-1}gy \in h^{-1}g(V_{j-1})$, and therefore x belongs to the union that was discarded from U_j when defining V_j , which is a contradiction.

Now let F be a Følner set large enough that $F \supset H^{-1}H$ (such an F exists, since every element of G belongs to every Følner set from some point onwards). Let $x \in X$. There exists a smallest j such that $x \in U_j$. If $x \notin V_j$, then x must belong to the union $\bigcup_{g, h \in H} g^{-1}h(V_{j-1}) \subset \bigcup_{g \in F} g(V_{j-1}) \subset \bigcup_{g \in F} g(V)$. On the other hand, if $x \in V_j$, then obviously $x \in V$, and thus the set $\bigcup_{g \in F} g(V)$ contains all of X .

□

Corollary 1.11. *Let X and G be as above. For every $x \in X$ and every finite $T \subset G$ there is a set $C(x) \subset G$ such that*

- (1) $Tg \cap Tg' = \emptyset$ for each pair $g, g' \in C(x), g \neq g'$,
- (2) lower Banach density of $C(x)$ is bounded away from zero. Even more, there is a set F such that for every $x \in X$ and every $g \in G$ it holds that $C(x) \cap Fg \neq \emptyset$.

Moreover,

$$C(gx)g = C(x) \tag{3}$$

for all $g \in G$ and the map $x \mapsto C(x)$ is continuous in this sense that for any Følner set F the sets $C(x)$ and $C(x')$ agree on F if x and x' are close enough.

Proof. Let V be a clopen set obtained by applying Marker lemma to the set $H = T^{-1}T$. Define $C(x) = \{g \in G: gx \in V\}$. Note that this immediately implies that $C(hx)h = C(x)$ for each $h \in G$. Suppose $g \in C(x)$. If $Tg \cap Tg' \neq \emptyset$, $g \neq g'$, then $g' \in T^{-1}Tg = Hg$, so $g'g^{-1} \in H$. But $g'x = g'g^{-1}gx \in g'g^{-1}(V)$. Since both the neutral element e and $g'g^{-1}$ are in H , the sets V and $g'g^{-1}V$ are disjoint, so $g'x \notin V$, meaning $g' \notin C(x)$. This proves (1).

To prove the assertion about lower Banach density, notice that for every g it holds that $\bigcup_{f \in F} gf(V) = X$ provided that $\bigcup_{f \in F} f(V) = X$. Hence, for every $x \in X$ and every $g \in G$ there is $f \in F$ such that $x \in g^{-1}f(V)$, i.e. $f^{-1}gx \in V$ or, in other words, $f^{-1}g \in C(x)$. We obtain $D_{F^{-1}}(C(x)) = \inf_g \frac{|C(x) \cap F^{-1}g|}{|F^{-1}|} \geq \frac{1}{|F|}$. Hence $D(C(x)) \geq \frac{1}{|F|}$.

Continuity of $x \mapsto C(x)$ stems from the fact that V obtained in Marker lemma is clopen, hence for g from a finite set F images gx simultaneously fall into V or stay outside V for x, x' close enough. \square

2. The model

Let (F_n) be a Følner sequence in G . Let (ε_k) be a summable sequence of positive numbers. For the sake of convenience, we fix a selection function π which assigns to a pair (D, N) , where D is a subset of G containing at least N elements, a sequence $\pi(D; N)$ of N different elements of D . We will define a sequence of block codes Φ_k defined on the array representation \widehat{X} of X using an inductive procedure. Certain aspects of the construction cause the first two steps to be slightly different (simpler) than subsequent ones, which is why we will begin by describing Steps 1 and 2 of the construction, and then proceed to describe the procedure of Step $k + 1$ based on Step k .

Step 1. Let $T_0 = \{e\}$ and let $\mathcal{B}_1 = (B_1^1, B_2^1, \dots, B_{N_1}^1)$ be an ε_1 -dense family of blocks with domain T_0 occurring in \widehat{X} , which in this step is just an ε_1 -dense set of symbols from the alphabet Λ , occurring in \widehat{X} . Apply Corollary 1.11 to T_0 , obtaining for every $x \in X$ a set $C_1'(x)$ such that the sets T_0c are pairwise disjoint for $c \in C_1'(x)$ and the set $T_0C_1'(x)$ has positive lower Banach density. Choose m_1 so that for every $g \in G$, $x \in X$, the set $F_{m_1}g$ contains at least N_1 elements $c \in C_1'(x)$ and its cardinality satisfies $\varepsilon_1 |F_{m_1}| > N_1$. (To obtain F_{m_1} choose F whose existence is granted by (2) of Corollary 1.11, find a Følner set

which contains N_1 disjoint copies Fg_1, \dots, Fg_{N_1} of F , then choose m_1 so that F_{m_1} contains $\bigcup_{i=1}^{N_1} Fg_i$; increase m_1 if necessary to fulfil the size conditions).

Now apply Corollary 1.11 to F_{m_1} (playing a role of T), obtaining a set $C_1(x)$ for every $x \in X$. For every $x \in X$ and every $c \in C_1(x)$ the set $D = F_{m_1} \cap C'_1(x)c^{-1}$ contains an N_1 -element sequence $\pi(D; N_1)$. Let

$$(d_1^c, \dots, d_{N_1}^c) = \pi(D; N_1)c \subset F_{m_1}c \cap C'_1(x).$$

The point $\Phi_1(\hat{x})$ will be created by replacing the content of $\hat{x}(T_0d_j^c)$ (i.e. a symbol at $\hat{x}(d_j^c)$) by B_j^1 for $j = 1, \dots, N_1$, rewriting the erased part of a trajectory of x (which originally was in row 0) to row 1, adding the symbol $*$ in row -1 at coordinates d_j^c and making no other changes. Namely, for $1 \leq j \leq N_1$, let

$$D_j(x) = \{d_j^c : c \in C_1(x)\},$$

and define for $g \in D_j(x)$, where $j = 1, \dots, N_1$,

$$\Phi_1(\hat{x})_{n,g} = \begin{cases} * & \text{if } n = -1, \\ B_j^1(0) & \text{if } n = 0, \\ \hat{x}_{0,g} & \text{if } n = 1, \end{cases}$$

and $\Phi_1(\hat{x})_{n,g} = \hat{x}_{n,g}$ otherwise (by $B_j^1(0)$ we mean a symbol which lies on zero level of the block). Continuity of the maps $C_1(x)$ and $C'_1(x)$, and their behaviour under the action of G , mean that the map Φ_1 is continuous and commutes with the action of G . In fact, it may be considered a block code. Furthermore, as $\Phi_1(\hat{x})$ retains the original non-zero symbols of \hat{x} (they were moved to row 1 at the coordinates that were changed), it is invertible, i.e. the systems \hat{X} and $\Phi_1(\hat{X})$ are conjugate. We will now show that for any $x \in X$ every element of \mathcal{B}_1 occurs in $\Phi_1(\hat{x})$ syndetically. Indeed, by Corollary 1.11 there exists a set $E \subset G$ such that $Eg \cap C_1(x)$ is nonempty for every $g \in G$ (note that E does not depend on x). Therefore, for every $g \in G$ the set T_1g , where $T_1 = F_{m_1}E$, contains $F_{m_1}c$ for some $c \in C_1(x)$, which implies that every block from \mathcal{B}_1 occurs in $\Phi_1(\hat{x})$ inside T_1g , which is the definition of syndeticity. Moreover, we may assume that T_1 is symmetric, i.e. $T_1^{-1} = T_1$ (if not then replace it with $T_1^{-1}T_1$).

Finally, we choose H_1 using Lemma 1.8 for $F = T_1$ and $l = 5$ (in fact, the choice of l is insignificant in this step, because we will deal with the set of the form T_1A). The set H_1 will replace T_1 in the role of being a ‘‘syndeticity constant’’ for occurrence of elements of \mathcal{B}_1 in subsequent systems we will create (T_1 itself would be too small). For convenience, we denote $X_1 = \Phi_1(\hat{X})$.

Step 2. Now let $\mathcal{B}_2 = (B_1^2, B_2^2, \dots, B_{N_2}^2)$ be an ε_2 -dense family of blocks with domain T_1 occurring in X_1 , $N_2 = |\mathcal{B}_2|$. Apply Corollary 1.11 to the set $H_1^{-1}T_1$

obtaining for every $x \in X_1$ some set $C'_2(x)$. Note that for distinct $c, c' \in C'_2(x)$ each set H_1g ($g \in G$) intersects at most one of T_1c, T_1c' . Indeed, if it intersected both of them then we would have $g \in H_1^{-1}T_1c \cap H_1^{-1}T_1c'$, contradicting (1) of Corollary 1.11. Similarly as before, choose m_2 so that for every $g \in G, x \in X_1$, the set $F_{m_2}g$ contains at least N_2 elements $c \in C'_2(x)$ such that $T_1c \subset F_{m_2}g$; we can also request that $N_2|T_1|^2 < \varepsilon_2|F_{m_2}|$. (The set F_{m_2} is obtained using the same procedure as in Step 1: choose F by (2) of Corollary 1.11, find a Følner set which contains N_2 disjoint copies Fg_1, \dots, Fg_{N_2} of F , then choose m_2 so that F_{m_2} contains $\bigcup_{i=1}^{N_2} T_1Fg_i$; increase m_2 if necessary to fulfil the size conditions).

As in Step 1, apply Corollary 1.11 to F_{m_2} , obtaining a set $C_2(x)$ for every $x \in X_1$. For every $x \in X_1$ and every $c \in C_2(x)$ the set $D = F_{m_2} \cap C'_2(x)c^{-1}$ contains a N_2 -element sequence $\pi(D; N_2)$. Let

$$(d_1^c, \dots, d_{N_2}^c) = \pi(D; N_2)c \subset F_{m_2}c \cap C'_2(x).$$

We will construct an auxiliary map $\Psi_2: X_1 \rightarrow \Lambda^G$ (we enumerate Ψ_k s starting from $k = 2$, because each Ψ_k is constructed in k th step). The point $\Psi_2(x)$ will be created by replacing the content of $x(T_1d_j^c)$ by B_j^2 for $j = 1, \dots, N_2$, rewriting the erased part of a trajectory of x (which at the moment was in rows 0 or 1) to row 2, adding the symbol $*$ in row -2 at coordinates d_j^c and 1 at other modified coordinates, and making no other changes. Namely, for $1 \leq j \leq N_2$, let

$$D_j(x) = \{d_j^c : c \in C_2(x)\},$$

and define

$$\Psi_2(x)_{n,g} = \begin{cases} * & \text{if } n = -2 \text{ and } g \in D_j(x), \\ 1 & \text{for } n = -2, g \in T_1d \text{ for some } d \in D_j(x), \\ & \text{but } g \notin D_j(x), \\ x_{N,g} & \text{for } n = 2, g \in T_1d \text{ for some } d \in D_j(x), \\ & \text{where } N = \max\{i : x_{i,g} \neq 0\}, \\ B_j^2(gd^{-1})(n) & \text{for } n = -1, 0, 1 \text{ and } g \text{ as above,} \end{cases}$$

and $\Psi_2(x)_{n,g} = x_{n,g}$ otherwise. Let $\Phi_2 = \Psi_2 \circ \Phi_1$. Same as before, the map Ψ_2 is a conjugacy between X_1 and its image, therefore Φ_2 is a conjugacy, too. Let $X_2 = \Psi_2(X_1) = \Phi_2(\hat{X})$. It follows from Corollary 1.11(2) that each element of \mathcal{B}_2 occurs in X_2 syndetically. More precisely, there is a set $E \subset G$ such that $Eg \cap C_2(x)$ is nonempty for every $g \in G$ and therefore, putting $T_2 = F_{m_2}E$, we obtain that T_2g contains some $F_{m_2}c, c \in C_2(x)$, for every $g \in G$. We can enlarge E to obtain $T_1^4 \subset E$ and assume that $T_2 = T_2^{-1}$, replacing T_2 with $T_2^{-1}T_2$ if necessary (required for further steps).

Moreover, elements of \mathcal{B}_1 also occur syndetically in X_2 . Indeed, let $\hat{x} \in X_2$ and let $g \in G$. By the construction of $C'_2(x)$, the set H_1g ($g \in G$) intersects at

most one T_1c for $c \in C'_2(x)$. By the choice of H_1 (see Step 1 and Lemma 1.8) there exists some h such that T_1h is a subset of H_1g that is either disjoint from all T_1c or is a subset of $T_1C'_2(x)$, in which case it must be exactly one of T_1c , $c \in C'_2(x)$. In either case, the block $\hat{x}(T_1h)$ is a block occurring in X_1 , since it was either in an area unchanged by Ψ_2 , or was entirely replaced by content of one of the blocks in \mathcal{B}_2 (all of which occur in X_1). By the construction of Φ_1 , this means that $\hat{x}(T_1h)$ contains all the blocks from \mathcal{B}_1 , which ultimately means that every block from \mathcal{B}_1 occurs syndetically in \hat{x} .

Finally, choose H_2 using Lemma 1.8 for $F = H_1^4T_2$ and $l = 5$. Note that each H_2g contains some T_2h , thus it contains all blocks from \mathcal{B}_2 .

Step $k + 1$. Suppose we have constructed:

- maps Φ_1, \dots, Φ_k , which are conjugacies mapping \hat{X} to X_k , where $X_k = \Phi_k(\hat{X}) \subset \Lambda^G$,
- $H_1, \dots, H_k, T_0, T_1, \dots, T_k$, which are subsets of G , where $T_i = T_i^{-1}$ for all i ,
- F_{m_1}, \dots, F_{m_k} , which are selected Følner sets,
- $\mathcal{B}_1, \dots, \mathcal{B}_k$, which are collections of blocks such that
 - (1) \mathcal{B}_j is a collection of blocks on the domain T_{j-1} , ε_j -dense in the collection of all such blocks occurring in X_{j-1} ,
 - (2) $T_j \subset H_j \subset T_{j+1} \subset H_k$ and $T_1^4 \dots T_j^4 \subset T_{j+1}$ for $j = 1, \dots, k - 1$,
 - (3) for any $j = 1, \dots, k$, every block with domain T_j in X_j has every block from \mathcal{B}_j as a subblock,
 - (4) for any $j = 1, \dots, k$ and any $i \geq j$, every block with domain H_j in X_i has every block from \mathcal{B}_j as a subblock,
 - (5) for every $A \subset G$ and $g \in G$ if $T_jA \subset E \subset T_j^5A$ then either $H_jg \setminus E$ contains T_jh or $H_jg \cap E$ contains T_jh for some $h \in H_jg$, $j = 1, \dots, k$,
 - (6) $|\mathcal{B}_j||T_{j-1}|^2 < \varepsilon_j|F_{m_j}|$ for $j = 1, \dots, k$.

We will make use of the following:

Enlarging algorithm

Let T be a set in G . Fix $x \in X$ and $k \in \mathbb{N}$. Let T' be the union of T and all sets of the form $T_k g$ (where g is any point such that $x(-k, g) = *$) that intersect $T_k T$. We put

$$E^1(T, x, k) = T_k T'$$

(see Figure 3). Then inductively we define

$$E^{j+1}(T, x, k) = E^1(E^j(T, x, k), x, k - j)$$

for $1 \leq j < k$ and

$$E(T, x, k) = E^k(T, x, k).$$

Note that $T_k T \subset E(T, x, k) \subset T_1^4 T_2^4 \dots T_k^4 T$. More precisely,

$$T_j E^{k-j}(T, x, k) \subset E(T, x, k) \subset T_1^4 \dots T_j^4 E^{k-j}(T, x, k)$$

for $1 \leq j < k$. Indeed, by the inductive assumption (2), we can even say that

$$T_j E^{k-j}(T, x, k) \subset E(T, x, k) \subset T_j^5 E^{k-j}(T, x, k).$$

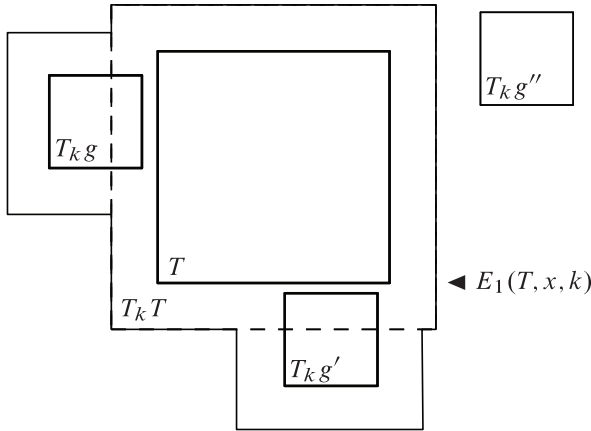

Figure 3. One step in the enlarging algorithm – formation of $E_1(T, x, k)$.

We proceed with the construction. Let $\mathcal{B}_{k+1} = (B_1^{k+1}, B_2^{k+1}, \dots, B_{N_{k+1}}^{k+1})$ be an ε_{k+1} -dense family of blocks with domain T_k , occurring in X_k . Let N_{k+1} be the cardinality of \mathcal{B}_{k+1} . Let $\bar{T} = T_1^4 T_2^4 \dots T_{k-1}^4 T_k$ (note that by our inductive assumptions, $T_k \subset \bar{T} \subset T_k^2$). Apply Corollary 1.11 to the set $H_k^{-1} \bar{T}$ obtaining for every $x \in X_k$ some set $C'_{k+1}(x)$. Note that for distinct $c, c' \in C'_{k+1}(x)$ each set $H_k g$ ($g \in G$) intersects at most one of $\bar{T}c, \bar{T}c'$. Moreover, $C'_{k+1}(x)$ has positive Banach density, therefore so do $\bar{T}C'_{k+1}(x)$ and $T_k C'_{k+1}(x)$. Similarly as before, choose m_{k+1} so big that for every $g \in G, x \in X$, the set $F_{m_{k+1}} g$ contains at least N_{k+1} elements $c \in C'_{k+1}(x)$ such that $T_k c \subset F_{m_{k+1}} g$; we assume that $N_{k+1} |T_k|^2 < \varepsilon_{k+1} |F_{m_{k+1}}|$.

Apply again Corollary 1.11 to $F_{m_{k+1}}$, obtaining for every $x \in X_k$ a set $C_{k+1}(x)$.

Similarly as in previous steps, for every $x \in X_k$ and every $c \in C_{k+1}(x)$ the set $D = F_{m_{k+1}} \cap C'_{k+1}(x)c^{-1}$ contains a N_{k+1} -element sequence $\pi(D; N_{k+1})$. Let

$$(d_1^c, \dots, d_{N_{k+1}}^c) = \pi(D; N_{k+1})c \subset F_{m_{k+1}} c \cap C'_{k+1}(x).$$

For rows from $-k$ to k we replace the current content of x within the domain $E := E(T_k d_j^c, x, k - 1)$ by the content of any block with domain E occurring in X_k and containing B_j^{k+1} as a subblock on coordinates from $T_k d_j^c$. We also rewrite the original trajectory of x to the $(k + 1)$ st row. To be precise, for $1 \leq j \leq N_{k+1}$ let

$$D_j(x) = \{d_j^c : c \in C_{k+1}(x)\}.$$

Denote $N(x, g) = \max\{j : x_{j,g} \neq 0\}$ and define

$$\Psi_{k+1}(\hat{x})_{n,g} = \begin{cases} * & \text{for } n = -(k + 1) \text{ and } g \in D_j(x), \\ 1 & \text{for } n = -(k + 1), g \in T_k d \\ & \text{for some } d \in D_j(x), \text{ but } g \notin D_j(x), \\ x_{N(x,g),g} & \text{for } n = k + 1 \\ & \text{and } g \in T_k d \text{ for some } d \in D_j(x), \\ B_j^{k+1}(gd^{-1})(n) & \text{for } n = -k, \dots, k \text{ and } g \text{ as above,} \\ & \text{with the rest of } E(T_k d_j, x, k - 1) \\ & \text{completed to a block} \\ & \text{occurring in } \Psi_k(\hat{X}), \end{cases}$$

and $\Psi_{k+1}(\hat{x})_{n,g} = x_{n,g}$ otherwise.

Let $\Phi_{k+1} = \Psi_{k+1} \circ \Phi_k$, $X_{k+1} = \Phi_{k+1}(\hat{X})$. Again it follows from the construction that Ψ_{k+1} and hence also Φ_{k+1} are conjugacies.

Since $C_{k+1}(x)$ was chosen with use of Corollary 1.11, there is a set E such that for every $x \in X_k$ and every $g \in G$ it holds that $C_{k+1}(x) \cap Eg \neq \emptyset$. Enlarging E we may assume that $T_1^4 \dots T_k^4 \subset E$. Let $T_{k+1} = F_{m_{k+1}} E$. Replace T_{k+1} with $T_{k+1}^{-1} T_{k+1}$ if it was not symmetric. Then $T_{k+1}g$ contains some $F_{m_{k+1}} c$, where $c \in C_{k+1}(x)$, for every $g \in G$. Consequently, any block with domain T_{k+1} in $X_{k+1} = \Psi_{k+1}(X_k)$ has every block from \mathcal{B}_{k+1} as a subblock.

Choose H_{k+1} using Lemma 1.8 for $F = T_{k+1}$ and $l = 5$. Note that each $H_{k+1}g$ contains $T_{k+1}g$, so all blocks from \mathcal{B}_{k+1} occur in each $H_{k+1}g$. Also, all changes in Step $k + 1$ were made on coordinates covered by sets of the form $T_k^2 g$, where g are such that $x(-(k + 1), g) = *$.

Now we will show that also for each $j = 1, \dots, k$ all blocks from \mathcal{B}_j occur in any block with domain $H_j g$ ($g \in G$) in X_{k+1} . Fix $g \in G$, $x \in X_k$ and $c \in C_{k+1}(x)$. For any set E of the form $E(T_k d, x, k - 1)$ (where $d \in D_j(x)$ for some j), there are three possibilities (indeed there is at most one such set for which one of the latter two is true). The set $H_j g \cap E$ can be empty, can be the whole of $H_j g$ or it can be something else. In the first two cases, the construction of Ψ_{k+1} implies that the block with domain $H_j g$ is a block occurring in X_k , and thus contains all blocks from \mathcal{B}_j by the inductive assumption (4). Thus we need only concern ourselves with the case when $H_j g \cap E$ is not empty, but $H_j g$ is not a subset

of E (let us reiterate that this can happen for at most one E among the sets we consider). The construction of E and our inductive assumptions imply that there is some h for which either $T_j h \subset H_j g \setminus E$ or $T_j h \subset H_j g \cap E$. Observe that $T_j h$ intersects no coordinates that were modified after Step j : if it did, then it would intersect a set of the form $T_{k'} g'$ (for $j < k' \leq k$ and g' such that $x(-k', g') = *$), but the enlarging algorithm would then cause $H_j g$ to be a subset of E . It follows that the block with domain $T_j h$ is a block occurring in X_j , thus it (as well as the larger block with domain $H_j g$) contains all blocks from \mathcal{B}_j .

3. The isomorphism

Let \tilde{X}_k^e be a subset of all $x \in X$ such that $\Phi_{k+1}(x)_e \neq \Phi_k(x)_e$. It is exactly the set of points whose Φ_k -image was modified on coordinate e by Ψ_{k+1} . By the ergodic theorem (see e.g. [6]), for each G -invariant ergodic measure μ on X it holds that

$$\mu(\tilde{X}_k^e) = \lim_{n \rightarrow \infty} \frac{1}{|F_n|} \sum_{g \in F_n} \mathbf{1}_{\tilde{X}_k^e}(g x) \quad \text{in } L^1(\mu).$$

Let F_{m_k} denote the Følner sets selected during the construction. The code Ψ_{k+1} introduces changes only on at most $|\mathcal{B}_{k+1}| |T_k|^2 < \varepsilon_{k+1} |F_{m_{k+1}}|$ coordinates of each block $x(F_{m_{k+1}} c)$, where $c \in C_{k+1}(x)$. We will estimate the number of changes in a block $x(F_n)$ for sufficiently large n . We choose n so big that F_n is $(F_{m_{k+1}}, \varepsilon_{k+1})$ -invariant. For each $c \in C_{k+1}(x) \cap F_n$ the set $F_{m_{k+1}} c$ is a subset of $F_{m_{k+1}} F_n$, the latter having less than $(1 + \varepsilon_{k+1}) F_n$ elements. Since $F_{m_k} c \cap F_{m_k} c' = \emptyset$ for $c \neq c', c, c' \in C_{k+1}(x)$, the set F_n may contain at most $\frac{(1 + \varepsilon_{k+1}) |F_n|}{|F_{m_{k+1}}|}$ elements of $C_{k+1}(x)$. Moreover, F_n may intersect $F_{m_{k+1}} c$ for some $c \in C(x) \setminus F_n$, but then $c \in F_{m_{k+1}}^{-1} F_n = F_{m_{k+1}} F_n$. Total number of changes made by Ψ_{k+1} is thus less than

$$\left(\frac{(1 + \varepsilon_{k+1}) |F_n|}{|F_{m_{k+1}}|} + \varepsilon_{k+1} |F_n| \right) \cdot |\mathcal{B}_{k+1}| |T_k|^2 < \varepsilon_{k+1} (1 + 2\varepsilon_{k+1}) |F_n|.$$

Therefore, $\mu(\tilde{X}_k^e) \leq \varepsilon_{k+1} (1 + 2\varepsilon_{k+1}) < 2\varepsilon_{k+1}$.

Let $\tilde{X} \subset X$ be the set of such $x \in X$ that for each $g \in G$ the sequence $\Phi_k(x)_g$ is eventually constant, i.e.

$$\tilde{X} = \bigcap_{g \in G} \bigcup_{k=1}^{\infty} \bigcap_{j=k}^{\infty} X \setminus g(\tilde{X}_j^e) = X \setminus \bigcup_{g \in G} \bigcap_{k=1}^{\infty} \bigcup_{j=k}^{\infty} g(\tilde{X}_j^e)$$

Since ε_k is summable, $\mu(\bigcup_{j=k}^{\infty} g(\tilde{X}_j^e))$ converges to zero when k goes to infinity and therefore \tilde{X} has full measure. Consequently,

$$\Phi(x) = \lim_{k \rightarrow \infty} \Phi_k(x)$$

is defined on a full subset of X (almost everywhere for each G -invariant measure). Let Y be the closure of $\Phi(\tilde{X})$ in Λ^G . Clearly, it is G -invariant. By essentially the same argument as in [1] and [3] one can prove the following proposition.

Proposition 3.1. (1) $\Phi(\tilde{X})$ is a full subset of Y .

(2) Φ is an equivariant Borel-measurable bijection onto a full set.

(3) Φ^* is an affine homeomorphism between simplices of invariant measures on X and Y .

Proof. For $y \in Y$ take $(y_n) \subset \Phi(\tilde{X})$, $y_n = \Phi(x_n)$, converging to y . Let Y_k^e be the set of all this $y \in Y$ for which $y_{-k,e} \neq 0$. For sufficiently large n on the set F_m the positions of symbols in y from $-k$ up to level k coincide with those in y_n . Non-zero symbols appear on the $-k$ th level of y_n only at coordinates on which x_n was modified by Ψ_k . Hence, for any G -invariant measure ν on Y the number $\nu(Y_k^e)$ is estimated similarly to the case of \tilde{X}_k^e : the frequency of non-zero symbols on $-k$ th level of $x(F_{m_k})$ is bounded by ε_k , and again by the ergodic theorem

$$\nu(Y_k^e) = \lim_{m \rightarrow \infty} \frac{1}{|F_m|} \sum_{g \in F_m} \mathbf{1}_{Y_k^e}(gx) < \varepsilon_k.$$

Hence the set

$$\tilde{Y} = \bigcap_{g \in G} \bigcup_{k=1}^{\infty} \bigcap_{j=k}^{\infty} Y \setminus g(Y_k^e) = Y \setminus \bigcup_{g \in G} \bigcap_{k=1}^{\infty} \bigcup_{j=k}^{\infty} g(Y_k^e),$$

is a full set. Notice that for each $y \in \tilde{Y}$ and every $g \in G$ the elements $y_{n,g}$ are eventually zero (both when $n \rightarrow \infty$ and $n \rightarrow -\infty$).

We need to show that Φ maps \tilde{X} onto \tilde{Y} . Choose $y \in \tilde{Y}$. Let $x \in X$ be the element lying on the last non-zero level of $y_{\cdot,e}$. Let $y = \lim_{n \rightarrow \infty} y_n$, $y_n \in \Phi(\tilde{X})$, $\Phi(x_n) = y_n$. Consider some Følner set F_k . On F_k the point y has zeros on levels higher than some N . For n sufficiently large, all y_n have zeros on levels higher than N . Hence all coordinates of x_n belonging to F_k were changed at most N times. It means that $\Phi(x_n)_{l,g} = \Phi_N(x_n)_{l,g} = \Phi_{N+i}(x_n)_{l,g}$ for $g \in F_k$ and $i \geq 1$. Since Φ_n is a block code, it is continuous, thus $\Phi_N(x) = \lim_{n \rightarrow \infty} \Phi_N(x_n) = \lim_{n \rightarrow \infty} \Phi_{N+i}(x_n) = \Phi_{N+i}(x)$. Consequently, in x coordinates $g \in F_k$ are modified at most N times by codes Φ_N . Since F_k is an arbitrarily big Følner set, $x \in \tilde{X}$. At the same time, the content of x at these coordinates coincides with the content of $y = \lim_n y_n$, so $y = \Phi(x)$.

Injectivity follows easily from the fact that the last non-zero levels of $\Phi(x)$ contain the orbit of x under the action of G .

The map Φ is measurable, because it is a limit of (continuous) block codes. Both spaces are compact, hence standard Borel, so the inverse is automatically measurable. This ends the proof of (1) and (2).

The map Φ^* is obviously affine, its bijectivity follows from the fact that Φ is a bijection between full sets, so it suffices to show that it is continuous (note that sets of invariant measures are compact). We skip this argument, because it is almost identical to the one for the \mathbb{Z}^d case presented in [3]. \square

4. Minimality

Minimality of the system (Y, G) follows from the following lemma.

Lemma 4.1. *Let (Y, G) be an array system, $Y \subset \Lambda^G$. Let \mathcal{B}_Y be the collection of all blocks occurring in Y and let $\mathcal{B}'_Y \subset \mathcal{B}_Y$ be a countable collection of blocks such that for every $\varepsilon > 0$ and every $B \in \mathcal{B}_Y$ there exists $B' \in \mathcal{B}'_Y$ such that $D(B, B'') < \varepsilon$ for some subblock B'' of B' .*

If there exist a dense subset Y' of Y consisting of elements y in which every $B \in \mathcal{B}'_Y$ occurs syndetically then the symbolic system (Y, σ) is minimal.

Proof. Let us metrize the topology in Λ^G , $G = \{g_1, g_2, \dots\}$, by

$$\rho(x, y) = \max_{n \in \mathbb{N}} \frac{d_\Lambda(x(g_n), y(g_n))}{n}.$$

We fix $x \in Y$ and aim to prove that the orbit $\{gx : g \in G\}$ is dense in Y . Let $\varepsilon > 0$ and let $y \in Y$. We will show that $\rho(gx, y) < \varepsilon$ for some $g \in G$. Let $y' \in Y'$ satisfy $\rho(y, y') < \frac{\varepsilon}{3}$. Choose $N \in \mathbb{N}$ such that $\frac{1}{N} \text{diam } \Lambda < \frac{\varepsilon}{3}$ and let F be a Følner set containing $\{g_1, \dots, g_N\}$. Denote by $y'(F')$ a block being the restriction of y' to the domain F . It follows from the assumption that we can find a block $B' \in \mathcal{B}'_Y$ such that $D(y'(F), B'') < \frac{\varepsilon}{3}$ for some subblock B'' of B' . Note that B'' occurs in each element z of Y' syndetically, i.e. there is a finite set $H \subset G$ such that B'' (possibly translated) is a subblock of $z(Hg)$ for each $g \in G$. In particular, it is so for g being the neutral element, i.e. there is h such that $Fh \subset H$ and $B'' = z(Fh) = hz(F)$. It follows that $h \in H$, because Følner sets contain the neutral element.

Since H is finite, we can approximate a point x (fixed at the beginning) by $x' \in Y'$ so that $\rho(x, x') < \delta$, where delta is small enough to ensure that $\rho(hx, hx') < \frac{\varepsilon}{3}$ for all $h \in H$. For some $h_0 \in H$ we have $h_0x'(F) = B''$, hence for each $f \in F$ it holds that

$$d_\Lambda((h_0x')(f), y'(f)) \leq D(h_0x'(F), y'(F)) = D(B'', y'(F)) < \frac{\varepsilon}{3}.$$

Since $F \supset \{g_1, \dots, g_N\}$, for $f \notin F$ we have $\frac{1}{N}d_\Lambda((h_0x')(f), y'(f)) < \frac{\varepsilon}{3}$, so $\rho(h_0x', y') \leq \frac{\varepsilon}{3}$ and

$$\rho(h_0x, y) \leq \rho(h_0x, h_0x') + \rho(h_0x', y') + \rho(y', y) < \varepsilon. \quad \square$$

Note that in our case the union $\bigcup_{k=1}^{\infty} \mathcal{B}(X_k)$ is a collection of blocks with the desired property. Indeed, each block occurring in $\Phi(\tilde{X})$ occurs already in one of X_k , because each coordinate of \tilde{X} was modified only finitely many times. Note that the distance between blocks majorizes the distance between their subblocks sharing the same domain. Since $\Phi(\tilde{X})$ is dense in Y , the main Theorem 1.2 is proved.

References

- [1] T. Downarowicz, Minimal models for noninvertible and not uniquely ergodic systems. *Israel J. Math.* **156** (2006), 93–110. [Zbl 1131.37012](#) [MR 2282370](#)
- [2] W. R. Emerson, Large symmetric sets in amenable groups and the individual ergodic theorem. *Amer. J. Math.* **96** (1974), 242–247. [Zbl 0296.22008](#) [MR 0354925](#)
- [3] B. Frej and A. Kwaśnicka Minimal models for \mathbb{Z}^d -actions. *Colloq. Math.* **110** (2008), no. 2, 461–476. [Zbl 1144.28007](#) [MR 2353916](#)
- [4] H. Furstenberg and B. Weiss, On almost 1–1 extensions. *Israel J. Math.* **65** (1989), no. 3, 311–322. [Zbl 0676.28010](#) [MR 1005015](#)
- [5] I. Kornfeld and N. Ormes, Topological realizations of families of ergodic automorphisms, multitowers and orbit equivalence. *Israel J. Math.* **155** (2006), 335–357. [Zbl 1131.37008](#) [MR 2269434](#)
- [6] E. Lindenstrauss, Pointwise theorems for amenable groups. *Electron. Res. Announc. Amer. Math. Soc.* **5** (1999), 82–90. [Zbl 0944.28014](#) [MR 1696824](#)

Received October 23, 2014

Bartosz Frej, Faculty of Pure and Applied Mathematics,
Wrocław University of Science and Technology, Wybrzeże Wyspiańskiego 27,
50-370 Wrocław, Poland

e-mail: Bartosz.Frej@pwr.edu.pl

Dawid Huczek, Faculty of Pure and Applied Mathematics,
Wrocław University of Science and Technology, Wybrzeże Wyspiańskiego 27,
50-370 Wrocław, Poland

e-mail: Dawid.Huczek@pwr.wroc.pl