

Monadic second-order logic and the domino problem on self-similar graphs

Laurent Bartholdi

Abstract. We consider the domino problem on Schreier graphs of self-similar groups, and more generally their monadic second-order logic. On the one hand, we prove that if the group is bounded, then the domino problem on the graph is decidable; furthermore, under an ultimate periodicity condition, all its monadic second-order logic is decidable. This covers, for example, the Sierpiński gasket graphs and the Schreier graphs of the Basilica group. On the other hand, we prove undecidability of the domino problem for a class of self-similar groups, answering a question by Barbieri and Sablik, and study some examples including one of linear growth.

1. Introduction

The *domino problem* is (in spite of its connection to monadic second-order logic, see Section 1.3) a mockingly elementary question to ask of an edge-labelled graph: “given a collection of labelled dominoes (with colours from a finite set on their ends), can one put a domino on each edge of the graph in such a manner that edge labels and vertex colours match?”

This problem is clearly solvable by brute force if the graph is finite, and it is easy to see that it is solvable if the graph is a line. Remarkably, if the graph is the square grid (with edges labelled vertical/horizontal), then this problem is unsolvable, as was shown by Berger [5].

This result should not be considered negative; it rather points to the universal computing power present in the square grid. It is a fundamental and natural problem to delineate the frontier between decidability and undecidability, in terms of the structure of the underlying graph.

A large source of labelled graphs worth studying arises from group theory: given a group G with finite generating set A and acting on a space X , consider the graph with vertex set X , having for all $s \in A$, $x \in X$ an edge labelled s from x to sx . Such graphs are known as *Schreier graphs* since their appearance in [19]. In this setting, an instance of the domino problem is a subset $\Theta \subseteq B \times A \times B$ for some finite set B , and the question is whether there exists a colouring $\tau: X \rightarrow B$ with $(\tau(x), s, \tau(sx)) \in \Theta$ for all $s \in A$, $x \in X$.

1.1. Decidability results

Our first “positive” result concerns graphs with an abundance of local cut points. These graphs are intimately connected to *finitely ramified fractals*, and Schreier graphs of *bounded self-similar groups*, see just below for definitions. This result will be extended, in Section 1.3, to decidability of the graph’s monadic second-order theory.

Theorem A (= Proposition 4.1). *The domino problem is decidable on post-critically finite self-similar graphs.*

The model of such graphs is a discrete avatar of the Sierpiński gasket; it is the subgraph of the square grid \mathbb{N}^2 induced by $\{(m, n) \in \mathbb{N}^2 : \binom{n}{m} \text{ is odd}\}$.

A *transducer* is a finite rooted graph Φ with input and output labels in a finite set S on every edge, and such that at every vertex and for every $s \in S$ there is a single outgoing edge with input label s . The transducer produces a transformation ϕ of the space $S^{\mathbb{N}}$ of right-infinite strings over S , as follows: given $\xi \in S^{\mathbb{N}}$, there is a unique right-infinite path, starting at the root, and with input labels ξ ; then $\phi(\xi) \in S^{\mathbb{N}}$ are the output labels along this path. Fixing one transducer Φ and varying its root produces a finite collection of transformations, and if all of them are invertible, then the group of permutations of $S^{\mathbb{N}}$ that they generate is called a *self-similar group*; its generating set is naturally in bijection with the vertex set of Φ . Some very small transducers produce rich and interesting groups, see Section 4.1 for an example called the “Hanoi tower group” in connection with the Sierpiński gasket, see Figure 1 (left). The graphs that we are interested in are Schreier graphs of self-similar groups on the orbit of a ray $\xi \in S^{\mathbb{N}}$, henceforth called *self-similar graphs*.

The self-similar group associated with a transducer Φ is *bounded*, a.k.a. *post-critically finite* (see Section 3.1), if the exiting arrows along every oriented cycle in Φ all eventually lead to a vertex representing the identity transformation. The corresponding Schreier graphs are closely related to a self-similar compactum known under various names in the literature: “hierarchical fractal”, “nested fractal”, or “finitely ramified fractal”. Kigami considers in [14] a compact space K and a family of self-maps $(F_s)_{s \in S}$ of K , such that there exists a “coding map” $\pi: S^{-\mathbb{N}} \rightarrow K$ with $\pi(ws) = F_s(\pi(w))$ for all left-infinite words $w \in S^{-\mathbb{N}}$ and all $s \in S$. *Tiles* of level n are images of cylinders, namely $\pi(S^{-\mathbb{N}}v)$ for a word $v \in S^n$. A graph is then associated with every such compactum: consider the graph whose vertices are all depth- n tiles, with an edge between two tiles if they intersect; and take a limit of such graphs as $n \rightarrow \infty$. For example, the Sierpiński gasket admits three contractions F_1, F_2, F_3 onto its level-1 tiles, and the associated graph is essentially the graph mentioned above.

General constructions by Nekrashevych [18] establish a duality between certain (“contracting”) self-similar groups and expanding self-covering maps on a compact set called *limit space*. We take in Section 3 the opportunity to clarify the connection between Kigami’s and Nekrashevych’s definitions: Nekrashevych’s limit space L is a quotient of Kigami’s space K , and the F_s are branches of the self-covering of L . Kigami’s “ancestor

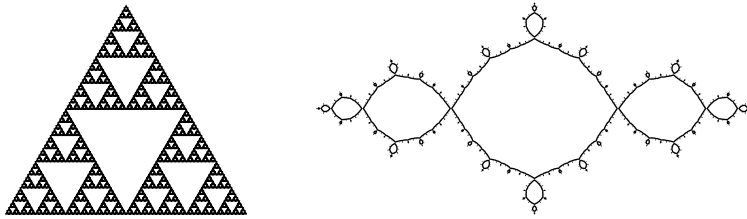

Figure 1. The Sierpiński and Basilica finitely ramified fractals.

structure”, a combinatorial gizmo extracted from (K, S) and powerful enough to allow reconstruction of (K, S) , may be directly produced from a transducer defining the bounded self-similar group.

A large family of self-similar groups and associated Schreier graphs arise from “iterated monodromy groups” of complex polynomials whose critical points are all ultimately periodic. We shall not need the definition of “iterated monodromy groups”; it suffices to say that they are the algebraic counterpart to the dynamical system afforded by the polynomial acting on its Julia set. The associated graphs are thus limits of simplicial approximations of the Julia set of the polynomial. One prominent example, whose Schreier graphs have been extensively studied (see e.g. [9]), is the “Basilica group” associated with the polynomial $z^2 - 1$, see Figure 1 (right).

1.2. Undecidability results

Our next results are in the “negative” direction. Two examples of Schreier graphs of self-similar groups appeared to have good chances of being close to the frontier of (un)decidability of the domino problem: the “long range graph” and the “Barbieri–Sablik H -graph”. I am grateful to Ville Salo for discussions on translating the Barbieri–Sablik self-similar structure into a particularly simple automatic graph. I show that, for each of them, the domino problem is undecidable. This last graph serves to answer a question by Barbieri and Sablik, which will be reviewed later.

The “long range graph”, see Section 5.1, is a deterministic model of long range percolation on the integers: nearest neighbours are connected, and for all $s > 0$ points at distance 2^s apart are connected “with probability 2^{-s} ”, but in a deterministic manner: precisely if they belong to $2^s\mathbb{Z} + 2^{s-1}$.

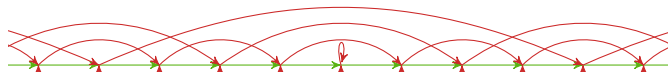

The transducer producing the long range graph looks as follows:

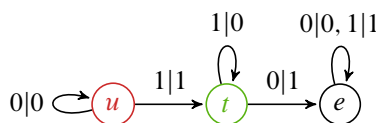

This transducer does not generate a bounded group, but rather a “linear growth group”: the number of paths of length n in the transducer not ending at the identity is not bounded, but grows linearly in n ; see [1, 22].

Theorem B (see Section 5.1). *The domino problem is undecidable on the long range graph.*

The second graph, the Barbieri–Sablik H -graph, is a subgraph of the half-plane, in which some edges are replaced by loops:

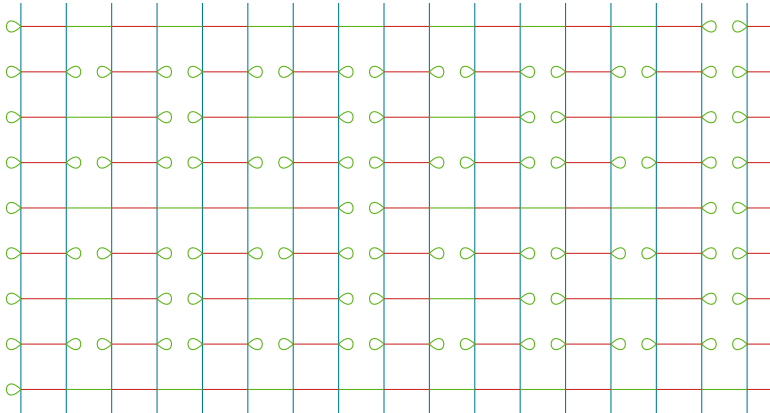

The transducer has the following form:

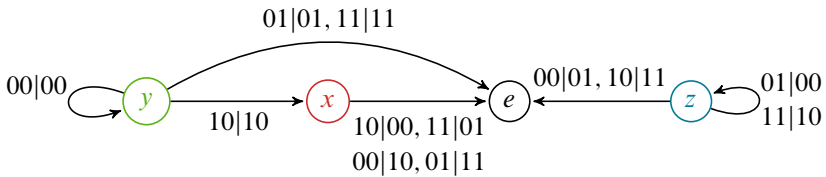

Theorem C (see Section 5.2). *The domino problem is undecidable on the Barbieri–Sablik H -graph.*

1.3. Monadic second-order logic

Consider an A -labelled graph Γ with root x_0 . Monadic second-order logic is concerned with formulas built from variables X, Y, \dots representing sets of vertices in Γ , the constant $\{x_0\}$, for all $a \in A$ an operation $a \cdot X$ representing all vertices reachable from X by following an a -labelled edge, the relation \subseteq , and usual boolean connectives \vee, \wedge, \neg and quantifiers \forall, \exists . The *monadic second-order theory* $\text{Mon}(\Gamma)$ consists of all formulas without free variables that hold in Γ .

Note that many usual graph-theoretic notions are readily definable in second-order logic; for example,

- the empty set is characterized by the formula $\phi(X) \equiv \forall Y[X \subseteq Y]$;
- ‘ $X = Y$ ’ is shorthand for ‘ $X \subseteq Y \wedge Y \subseteq X$ ’;
- ‘ $X \cap Y$ ’ is expressed as

$$\phi(Z) \equiv Z \subseteq X \wedge Z \subseteq Y \wedge \forall W[W \subseteq X \wedge W \subseteq Y \Rightarrow W \subseteq Z];$$

- singletons are characterized by $\phi(X) \equiv X \neq \emptyset \wedge \forall Y[Y \subset X \Rightarrow Y = \emptyset \vee Y = X]$. Vertices of Γ can be represented by singletons, and we write ‘ $x \in X$ ’ to mean ‘ $\{x\} \subseteq X$ ’.

As an example of the power of this logic, the graph Γ is connected if and only if

$$\forall X \left[X = \emptyset \vee X = \Gamma \vee \bigvee_{a \in A} a \cdot X \neq X \right].$$

We refer to [17, §3] for details.

More fundamentally, an instance $\Theta \subseteq B \times A \times B$ of the domino problem is easily translated to the sentence

$$\exists X_b (b \in B) \left[\bigsqcup_{b \in B} X_b = \Gamma \wedge \bigwedge_{(b,a,b') \notin \Theta} X_{b'} \cap a \cdot X_b = \emptyset \right].$$

For a “seeded” domino problem (Θ, b_0) , which we will consider in more detail in Section 2.1, one adds the clause ‘ $x_0 \in X_{b_0}$ ’.

The rooted graph Γ has *decidable monadic second-order theory* if there is an algorithm that, given a sentence ϕ in the logic of A -labelled graphs, decides whether ϕ holds in Γ . Thus if Γ has decidable monadic second-order theory, then the domino problem is decidable for Γ , and the domino problem is contained in the existential fragment of monadic second-order logic. We extend Theorem A as follows.

Theorem D (= Theorem 4.2). *The monadic second-order theory of a post-critically finite self-similar graph with ultimately periodic root is decidable.*

Note that in most cases of a self-similar group G acting on $S^{\mathbb{N}}$ all Schreier graphs $(G\xi, \xi)$ are non-isomorphic. Since there are continuously many $\xi \in S^{\mathbb{N}}$ but only countably many algorithms, most $(G\xi, \xi)$ have undecidable monadic second-order theory. This explains the restriction to graphs with ultimately periodic ξ .

1.4. Barbieri and Sablik’s self-similar structures

Barbieri and Sablik, in [2], consider the domino problem on self-similar structures. Their definition is tightly connected to the Euclidean grid: they consider a black/white colouring of the grid defined by iterating a substitution. They then consider domino problems on the grid, but for which the adjacency of tiles is only enforced on black cubes. For example, in dimension 2, consider the following substitution:

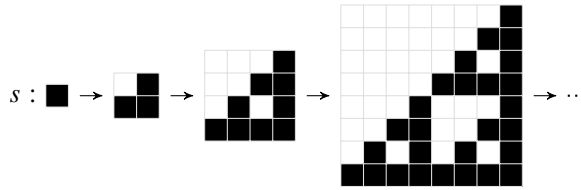

It produces essentially the same graph as the one associated with the Sierpiński gasket, by colouring the plane via a limit of s^n and considering the graph with one vertex per black square and an edge between touching squares.

More formally, fixing a substitution s as above, Barbieri and Sablik consider the following variant of the domino problem on \mathbb{Z}^d : “Given a set of colours $B = \{\circ\} \sqcup B_\bullet$ and tileset $\Theta \subseteq B \times \{-1, 0, 1\}^d \times B$, is it possible for all $n \in \mathbb{N}$ to tile $s^n(\blacksquare)$ using Θ in such a manner that white boxes are coloured \circ and black boxes B_\bullet ?” (This definition is a slight variant of theirs, and is equivalent if the black boxes are connected.)

Barbieri and Sablik classify substitutions into “bounded connectivity”, “isthmus”, and “grid” type, according to the number of black paths crossing $s(\blacksquare)$, and show that in the “bounded connectivity” case the domino problem is decidable, while in the “grid” case the domino problem is undecidable. They leave open the “isthmus case”, for which a prototypical substitution is

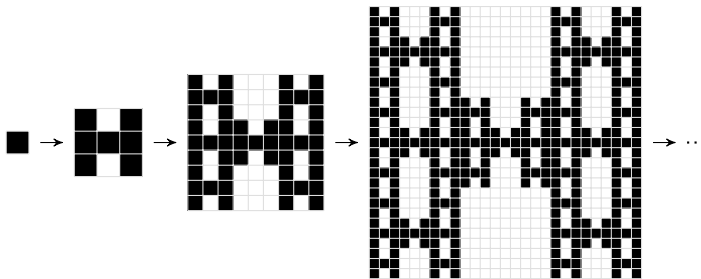

The right half of the corresponding graph is essentially the H -graph mentioned in Theorem C. Using this, we prove the following.

Theorem 1.1 (see Section 6.3). *The domino problem associated with a substitution s is undecidable if s contains an isthmus: a certain configuration of blocks forming at least two strips in one direction and one in another.*

1.5. Some conjectures and remarks

In fine, all proofs of undecidability of the domino problem, or more generally of the monadic second-order logic of a graph, seem to rely on “space-time diagrams”: there are subsets C_0, C_1, \dots of the graph on which the stateset of a machine (be it a Turing machine, or one of Kari’s piecewise-affine machines [12]) can be represented; and there are enough connections in the graph between C_t and C_{t+1} so that the one-step evolution of the machine can be logically enforced. If the C_t are actually subgraphs and the

machine’s state is represented by a bi-infinite tape, then each C_t is a copy of \mathbb{Z} and the space-time diagram is a copy of $\mathbb{Z} \times \mathbb{N}$. (Note that there are undecidable problems that do not reduce to undecidability of the halting problem – one speaks of Turing degrees strictly between $\mathbf{0}$ and $\mathbf{0}'$, see [16] – but I am not aware of any natural such example, a fortiori as a tiling problem.)

In terms of Schreier graphs, this means that if a subgroup $\mathbb{Z}^2 \leq G$ acts freely on an orbit $G \cdot \xi$, then the domino problem on the corresponding Schreier graph is undecidable; and much more general statements are true. Following [11], if G contains a direct product $H_1 \times H_2$ of two infinite, finitely generated groups, and each H_i with $i = 1, 2$ has all orbits infinite in its action on the space $H_{3-i} \setminus (G \cdot \xi)$ of orbits of the other factor, then the domino problem on the Schreier graph of $G \cdot \xi$ is also undecidable.

In [3], together with Ville Salo, I consider the domino problem on a Cayley graph Γ which does not contain any grid, the “lamplighter group” $\mathbb{Z}/2 \wr \mathbb{Z}$, and show that nevertheless its “seeded” domino problem (see Section 2.1) is undecidable. The main, general idea is that an auxiliary domino problem may be used to mark some vertices and some sequences of edges to simulate a grid within Γ . (In fact, it would be equally good to simulate any graph with unsolvable domino problem, but somehow we always fall back on the grid.) This is the argument used in Section 5 to prove Theorems B and C; though we do not make use of the general results of [3], and rather repeat the argument in each specific case.

It follows from Seese’s theorem [21] that the monadic second-order theory of a graph Γ is undecidable if it has unbounded *treewidth* (see Section 4.4); equivalently, if Γ contains arbitrarily large grids as minors. On the other hand, Ville Salo pointed out to me that, if Γ contains sufficiently sparse grids, then the domino problem may be decidable. For concreteness, consider a mutilated grid $\mathbb{Z} \times \mathbb{N}$ in which, at height $(j - 1)! + 1, \dots, j!$, the horizontal edges wrap in cycles of length 2^j ; then a tileset tiles this graph if and only if it tiles the plane periodically. This kind of phenomenon does not seem to be possible for Schreier graphs of self-similar groups:

Conjecture 1.2. *For G a contracting self-similar group, the following are equivalent:*

- (1) *the domino problem is decidable on all Schreier graphs of G ;*
- (2) *the monadic second-order theory is decidable on all Schreier graphs of G with a computable sequence as the root;*
- (3) *the limit space of G is finitely ramified.*

(We may take “finitely ramified” to mean that there is a discrete set of local cut points. For example, if G is conjugate to a bounded transducer group, then this will be the case. Conversely, I suspect that, if a digit tile is a post-critically finite fractal, then there exists a bounded group realizing it.)

2. The domino problem on graphs

A graph $\Gamma = (V, E)$ is a pair of sets called *vertices* and *edges*, with a *head* $e^+ \in V$ and a *tail* $e^- \in V$ for every $e \in E$. An *unoriented graph* has, furthermore, an involution $e \mapsto e'$ on E such that $(e')^\pm = e^\mp$. For a finite set A of labels, an *A-labelled graph* is a graph endowed with a labelling $\lambda: E \rightarrow A$ of its edges. A labelling is *proper* if no two edges have the same label and tail. By contrast, for a finite set B of colours, a *B-colouring* of Γ is a map $V \rightarrow B$, namely a colouring of the vertices of Γ .

The basic example of a labelled graph we have in mind is a *Schreier graph*: for a finitely generated group $G = \langle A \rangle$ acting on a set X , consider the graph with vertex set X and edge set $A \times X$, with $(a, x)^- = x$ and $(a, x)^+ = a \cdot x$ and $\lambda(a, x) = a$. Note that this defines a properly labelled graph. By extension, if Γ is a properly A -labelled graph, we write $a \cdot x$ for the head of the edge labelled a with tail x , if it exists. The *Cayley graph* is the Schreier graph of a group acting on itself by left-translation.

If furthermore $A = A^{-1}$ is symmetric, then the Schreier graph is unoriented, with $(a, x)' = (a^{-1}, a \cdot x)$. Consider for example the group $G = \mathbb{Z}^2$ acting on itself and generated by $\{(0, \pm 1), (\pm 1, 0)\}$; then the corresponding Schreier graph is the usual square grid.

The *domino problem* for an A -labelled graph $\Gamma = (V, E, \lambda)$ is the following decision problem: *given a finite A-labelled graph Δ , does there exist a graph morphism $\Gamma \rightarrow \Delta$?*

Thus an instance of the domino problem is a finite set B (the vertex set of Δ) and a subset Θ of $B \times A \times B$ (the edges of Δ , identified by their initial vertex, label and final vertex). The output should be “yes” if there exists a B -colouring $\tau: V \rightarrow B$ of Γ such that for every edge e of Γ one has $(\tau(e^-), \lambda(e), \tau(e^+)) \in \Theta$. We refer to Θ as a *tileset*, and to the valid colouring $\tau: V \rightarrow B$ as a *tiling*.

The reader may already be familiar with “Wang tiles”; these are squares with colours written on their four sides, and the classical domino problem in the plane is to determine, for a given set of Wang tiles, whether they can be used to cover the plane with matching colours. Let us connect this formalism with the above definition.

Formally, a set of Wang tiles, for a given set of colours C , is a subset $W \subseteq C^{\{S,E,N,W\}}$ $= C^4$. We say that W *tiles* if there exists a map $\tau: \mathbb{Z}^2 \rightarrow W$ with

$$\tau(m, n)_N = \tau(m, n + 1)_S \quad \text{and} \quad \tau(m, n)_E = \tau(m + 1, n)_W$$

for all $(m, n) \in \mathbb{Z}^2$. Consider the Cayley graph Γ of \mathbb{Z}^2 generated by $\{(0, \pm 1), (\pm 1, 0)\}$, and construct the graph Δ with vertex set W , an edge labelled $(1, 0)$ from w to w' (and one labelled $(-1, 0)$ from w' to w) whenever $w_E = (w')_W$, and an edge labelled $(0, 1)$ from w to w' (and one labelled $(0, -1)$ from w' to w) whenever $w_N = (w')_S$. Then W tiles precisely when there exists a graph morphism $\Gamma \rightarrow \Delta$.

By a classical argument, an instance of the domino problem may specify legal colourings of larger subgraphs than those given by the Θ above. Let us, for simplicity, restrict ourselves to the setting of Schreier graphs: let $G = \langle A \rangle$ be a group acting on a set X .

If B is a given set of colours, a *pattern* is an element of B^F for some finite subset F of G ; or, more precisely, for some finite subset F of the free group on A , since this is the only way in which elements of a general finitely generated group G may be specified. An instance of the domino problem is then a collection \mathcal{F} of “forbidden” patterns for some set B of colours, and the required output is whether there exists a colouring $\tau: X \rightarrow B$ that avoids all patterns in \mathcal{F} : for every $x \in X$ and every pattern $\pi: F \rightarrow B$ in \mathcal{F} , the assignment $F \ni f \mapsto \tau(fx) \in B$ is not equal to π .

Lemma 2.1. *The pattern formulation of the domino problem is equivalent to the original one.*

Proof. Consider first an instance of the domino problem given by $\Theta \subseteq B \times A \times B$. Then Θ is a set of patterns: the element (b, a, b') is the pattern supported on $\{1, a\}$ with values b, b' at $1, a$ respectively. Let \mathcal{F} be the set of patterns associated with $(B \times A \times B) \setminus \Theta$; then a vertex colouring avoids \mathcal{F} if and only if the graph’s edges are coloured by Θ .

Conversely, let \mathcal{F} be a finite collection of forbidden patterns. There exists $R \in \mathbb{N}$ such that all patterns in \mathcal{F} are supported on $\bar{A} := \{1\} \cup A \cup \dots \cup A^R$, the ball of radius R in G ; set then

$$\bar{B} := \{\beta \in B^{\bar{A}} : \text{for all } (\pi: F \rightarrow B) \in \mathcal{F} \text{ we have } \pi \neq \beta \upharpoonright F\}.$$

Let $\Theta \subseteq \bar{B} \times A \times \bar{B}$ be the set of (β, a, β') such that $\beta(g) = \beta'(ga^{-1})$ for all $g \in \bar{A} \cap \bar{A}a$.

Given a vertex colouring $\bar{\tau}: X \rightarrow \bar{B}$ with edges coloured by Θ , we consider the vertex colouring $\tau: X \rightarrow B$ given by $\tau(x) = \bar{\tau}(x)(1)$; then τ avoids all patterns in \mathcal{F} . Conversely, given $\tau: X \rightarrow B$ avoiding all patterns in \mathcal{F} , define $\bar{\tau}: X \rightarrow \bar{B}$ by $\bar{\tau}(x)(g) = \tau(gx)$ for all $x \in X, g \in \bar{A}$; then all edges are coloured by Θ : for $a \in A$ we have

$$\bar{\tau}(x)(g) = \tau(gx) = \tau(ga^{-1}ax) = \bar{\tau}(ax)(ga^{-1}),$$

so $(\bar{\tau}(x), a, \bar{\tau}(ax)) \in \Theta$.

We finally check that the maps $\tau \mapsto \bar{\tau}$ and $\bar{\tau} \mapsto \tau$ are inverses of each other. Starting from τ , we get $(\text{new } \bar{\tau})(x) = \bar{\tau}(x)(1) = \tau(x)$. Consider conversely a valid tiling $\bar{\tau}: X \rightarrow \bar{B}$; it suffices to prove $\bar{\tau}(x)(g) = \bar{\tau}(gx)(1)$ for all $x \in X, g \in \bar{A}$, since then

$$(\text{new } \bar{\tau})(x)(g) = (\text{new } \bar{\tau})(gx)(1) = \tau(gx) = \bar{\tau}(x)(g).$$

We prove the claim by induction over the minimal $r \in \mathbb{N}$ such that $g \in A^r$, the case $r = 0$ being trivial. For $r > 0$, write $g = ha$ with $h \in A^{r-1}$ and $a \in A$. Then $\bar{\tau}(gx)(1) = \bar{\tau}(hax)(1) = \bar{\tau}(ax)(h)$ by induction. Applying the condition Θ on the edge between x and ax gives, as required,

$$\bar{\tau}(x)(g) = \bar{\tau}(ax)(ga^{-1}) = \bar{\tau}(ax)(h) = \bar{\tau}(gx). \quad \blacksquare$$

The general formulation involves “patches”: a *patch* Δ is a rooted, connected, A -labelled, B -coloured finite graph, and a patch is said to *match* a graph colouring $\tau: \Gamma \rightarrow B$

at a vertex v if there exists a graph morphism $\Delta \rightarrow \Gamma$ mapping the root of Δ to v and preserving labels and colours. Let us restrict ourselves to graphs in which every label in A appears at most once on the edges issued from any vertex; that is, subgraphs of Schreier graphs for the free group F_A . In this manner, patches and patterns naturally correspond to each other: given a patch Δ , choose for every vertex of Δ a path from the root to it; let F denote the words along these paths, viewed as free group elements; and define a pattern by mapping these free group elements to the colour at the path's extremity. Thus Lemma 2.1 says that a domino problem may be specified by a collection of forbidden patches.

In this manner, the equivalent formulation of the tiling problem by Wang tiles, for an undirected Schreier graph X , is as follows. An instance of the problem is a finite set B of colours and a set $W \subseteq B^A$ of Wang tiles. A valid colouring is a map $\tau: X \rightarrow W$ such that $\tau(x)(a) = \tau(a \cdot x)(a^{-1})$ for all $x \in X, a \in A$.

It is sometimes interesting to consider the *space* of tilings of a graph given by a tileset: it is the space of graph morphisms $\Gamma \rightarrow \Delta$, with its natural (product, prodiscrete) topology. Assuming that $\Gamma = (V, E, \lambda)$ is properly labelled, for a tileset Θ we define

$$X_\Theta := \{ \tau \in B^V : \forall e \in E : (\tau(e^-), \lambda(e), \tau(e^+)) \in \Theta \}.$$

It is a closed subspace of B^V for the product topology. It is also invariant under the automorphism group of Γ ; so if $\text{Aut}(\Gamma)$ acts simply transitively on V , then it is an $\text{Aut}(\Gamma)$ -subshift of finite type.

The following result says that certain local configurations (for example closed paths) may be marked in labelled graph by means of a tileset, if we accept that sometimes more vertices than desired will be marked:

Lemma 2.2. *For every finite, rooted, labelled graph (Δ, x_0) , there exist a tileset $\Theta \subseteq B \times A \times B$ and a subset $C \subseteq B$, such that*

- (1) every B -colouring τ matching Θ satisfies

$$\tau^{-1}(C) \supseteq \{ v \in V : \text{there exists a graph morphism } (\Delta, x_0) \rightarrow (\Gamma, v) \};$$

- (2) there exists a B -colouring τ matching Θ and satisfying

$$\tau^{-1}(C) = \{ v \in V : \text{there exists a graph morphism } (\Delta, x_0) \rightarrow (\Gamma, v) \}.$$

Proof. It suffices to consider the case of Δ being a single, a -labelled loop; the general case follows from Lemma 2.1 and the considerations following it, relating Schreier graphs and labelled graphs. Select then $B = \{0, 1, 2, 3\}$ and $C = \{0\}$, and

$$\begin{aligned} \Theta = & \{ (0, a, 0) \} \cup \{ (i, a, j) : i \neq j \in \{1, 2, 3\} \} \\ & \cup \{ (i, x, j) : x \neq a \in A, i, j \in \{0, 1, 2, 3\} \}. \end{aligned}$$

No condition is imposed on x -labelled edges for $x \neq a$; all a -labelled loops must be coloured 0 while every a -labelled path (closed or not) may be labelled either entirely by 0, or alternating in 1, 2, 3 (we need three colours to cover all the cases of an even-length cycle, an odd-length cycle, or an open path). ■

2.1. Seeded domino problems

We shall also consider a variant of the domino problem in which the graph has a distinguished vertex, which has to be given a specific colour. Here is a formulation in terms of a rooted Schreier graph (X, x_0) : an instance of the *seeded* domino problem is a collection $\Theta \subseteq B \times A \times B$ of dominoes with a chosen $b_0 \in B$; the question is whether there exists an assignment $\tau: X \rightarrow B$ with $\tau(x_0) = b_0$ and $(\tau(x), a, \tau(ax)) \in \Theta$ for all $x \in X, a \in A$. If the seeded domino problem is solvable on a graph Γ , then so is the domino problem (by querying the seeded domino problem with all possible choices of colour at x_0). It could well be that each time the seeded domino problem is unsolvable, so is the domino problem; though for graphs such as the square grid \mathbb{Z}^2 , or tessellations of the hyperbolic plane, it took substantially more effort to prove the latter than the former.

Let $\Gamma = (V, E, \lambda)$ be an A -labelled graph, and let $v \in V$ be a distinguished vertex. The *sunny-side-up* is the subset $S_v \subseteq \{0, 1\}^V$ consisting of colourings $V \rightarrow \{0, 1\}$ with a single ‘1’ at an arbitrary position in the $\text{Aut}(\Gamma)$ -orbit of v ; and additionally the all-0 configuration, if the $\text{Aut}(\Gamma)$ -orbit of v is infinite. In particular, if Γ is infinite and vertex-transitive, for instance a Cayley graph, then S_v is naturally in bijection with the one-point compactification $V \cup \{\infty\}$ of V . We call S_v *sofic* if there exists a tilingset $\Theta \subset B \times A \times B$ and a map $\pi: B \rightarrow \{0, 1\}$ such that $S_v = \pi \circ X_\Theta$, namely S_v is obtained by projecting all valid Θ -tilings through π .

Lemma 2.3. *Let Γ be an A -labelled graph, with v a vertex as above, and assume that v has a finite $\text{Aut}(\Gamma)$ -orbit. If the sunny-side-up S_v is sofic, then the seeded and unseeded domino problems are reducible to each other.*

Proof. The unseeded tiling problem can always be solved by querying finitely many times the seeded tiling problem, with all choices of colours. Conversely, given an instance of the seeded tiling problem $\Theta_0 \subset B_0 \times A \times B_0$ and distinguished colour $b \in B$, let $\Theta_1 \subset B_1 \times A \times B_1$, let $\pi: B_1 \rightarrow \{0, 1\}$ be an encoding of S_v , and consider the tilingset

$$\Theta := \{((b_0, b_1), a, (b'_0, b'_1)) : (b_0, a, b'_0) \in \Theta_0, (b_1, a, b'_1) \in \Theta_1, \pi(b_1) = 1 \Rightarrow b_0 = b\}.$$

Any valid tiling by Θ consists of a valid tiling of Θ_0 which furthermore has b at a position marked by S_v , so Θ tiles if and only if Θ_0 tiles with colour b at v . ■

3. Self-similar graphs and spaces

Let us first recall how graphs appear in connection with self-similar fractals. Following Kigami [14], consider a compact set K with a collection $\{F_s : s \in S\}$ of injective continuous self-maps, and assume that there is a surjective continuous map $\pi: S^{-\mathbb{N}} \rightarrow K$ with $\pi(ws) = F_s(\pi(w))$ for all $s \in S, w \in S^{-\mathbb{N}}$. (The reason we write sequences as left-infinite will soon become clear.) The map π , if it exists, is unique, and the data (K, S) are called a *self-similar structure*. We denote by σ the shift map on $S^{-\mathbb{N}}$, defined by $\sigma(ws) = w$.

For a word $v \in S^*$ we set $K_v = \pi(S^{-\mathbb{N}}v)$; these are *tiles* covering K . The *critical set* $C \subseteq S^{-\mathbb{N}}$ is

$$C = \pi^{-1}\left(\bigcup_{s \neq t \in S} K_s \cap K_t\right),$$

and the *post-critical set* is

$$P = \bigcup_{n \geq 1} \sigma^n(C).$$

A self-similar structure is *post-critically finite* if P is finite. A simple example that is worth keeping track of is the following: $K = [0, 1]$ and $S = \{0, 1\}$ with $F_i(x) = (x + i)/2$. Then $C = \{\infty 01, \infty 10\}$ and $P = \{\infty 0, \infty 1\}$, with tiles the intervals

$$K_{w_1 \dots w_n} = [w_1/2 + \dots + w_n/2^n, w_1/2 + \dots + w_n/2^n + 1/2^n].$$

Self-similar structures naturally yield graphs as follows: for $n \in \mathbb{N}$, consider the graph Γ_n with vertex set S^n , and an edge between v and w whenever $K_v \cap K_w \neq \emptyset$. Moreover, it is possible to consider “limits” as $n \rightarrow \infty$ of these graphs, by “centering” them for all $n \in \mathbb{N}$ at the basepoint $\xi_1 \dots \xi_n$ given as prefix of an infinite word $\xi \in S^{\mathbb{N}}$. (Note here that ξ is a right-infinite word!). This can be seen more formally as follows: for $\xi \in S^{\mathbb{N}}$, consider the ascending union

$$\widehat{K}(\xi) = (K \times \mathbb{N}) / ((x, n) = (F_{\xi_n}(x), n + 1) \forall n \in \mathbb{N}).$$

It is naturally tiled by the tiles of the form $K_v \times \{|v|\}$ for all words $v \in S^*$, and we may again form a graph $\Gamma(\xi)$ with the collection of all tiles as vertex set, if one remembers that $K_v \times \{n\}$ and $K_{v\xi_{n+1}} \times \{n + 1\}$ are identified for all $v \in S^n$.

Still in our example, $\widehat{K}(\xi)$ is the union of the intervals $[0, 1] \times \{n\}$, each identified with the left or right half of the previous one $[0, 1] \times \{n - 1\}$ depending on ξ_n ; it is natural to view $[0, 1] \times \{n\}$ as an interval of size 2^n , so the identifications are isometric inclusions, so $\widehat{K}(\xi) = \mathbb{R}$, unless ξ eventually ends in 0^∞ when $\widehat{K}(\xi) = \mathbb{R}_+$, or ξ eventually ends in 1^∞ when $\widehat{K}(\xi) = \mathbb{R}_-$. The corresponding graphs are respectively \mathbb{Z} , \mathbb{N} and $-\mathbb{N}$.

In case (K, S) is post-critically finite, Kigami shows in [14, Appendix A] that it may be reconstructed from a small amount of combinatorial data: an *ancestor structure* is $(V, U, \{G_s\})$ for two finite sets $V \subseteq U$ and a collection of injective maps $G_s: U \rightarrow V$, such that $V = \bigcup_{s \in S} G_s(U)$, and if $U \neq \emptyset$, then $G_s(U) \setminus U \neq \emptyset$ for all $s \in S$. Starting from a post-critically finite self-similar structure, $U = \pi(P)$ and $V = \pi(PS)$ and $G_s = F_s \upharpoonright U$ define an ancestor structure. Conversely, an ancestor structure determines a compact set K and a self-similar structure as follows: for $x \in V$, define

$$A_x = \{w = (w_n) \in S^{-\mathbb{N}} : \exists(x_n) \in U^{-\mathbb{N}} \text{ with } G_{w_{-1}}(x_{-1}) = x \text{ and } w_n(x_n) = x_{n+1} \forall n \leq -2\}.$$

Set then

$$K = S^{-\mathbb{N}} / (vu \sim wu \text{ if } v = w \text{ or } \exists x \in V : v, w \in A_x),$$

and for all $s \in S$ let $F_s: K \rightarrow K$ be the map induced by $w \mapsto ws$ on $S^{-\mathbb{N}}$. It is easy to check that this construction recovers the original (K, S) . Again in our example, $U = \{0, 1\}$ and $V = \{0, \frac{1}{2}, 1\}$ with $A_{1/2} = \{\infty 01, \infty 10\}$.

3.1. Bounded transducers

An algebraic formalism described by Bondarenko and Nekrashevych in [7] is closely related to the ancestor structures above.

We recall that a *self-similar group* is a group G endowed with a map $\Phi: G \times S \rightarrow S \times G$ for some finite set S , satisfying for all $g, h \in G$ and $s \in S$ the condition

$$\Phi(gh, s) = (s'', g'h') \text{ whenever } \Phi(h, s) = (s', h') \text{ and } \Phi(g, s') = (s'', g').$$

This is equivalent to requiring that $S \times G$ admits the structure of a G - G -biset: it has two commuting G -actions, given by $g \cdot (s, h) \cdot k = (s', g'hk)$ if $\Phi(g, s) = (s', g')$.

From the self-similarity map Φ one constructs an action of G on $S^{\mathbb{N}}$ as follows: given a word $\xi = \xi_1 \xi_2 \dots \in S^{\mathbb{N}}$ and an element $g \in G$, to define $g(\xi)$ set $g_0 = g$ and for every $n \geq 1$ set $(\xi'_n, g_n) := \Phi(g_{n-1}, \xi_n)$; then $g(\xi) = \xi'_1 \xi'_2 \dots$. In other words, we have a recursive formula $g(\xi_1 \xi_2 \dots) = \xi'_1 g_1(\xi_2 \dots)$ with $\Phi(g, \xi_1) = (\xi'_1, g_1)$. The same formulas may be used to define an action of G on the set S^n of words of length n . In fact, the map Φ may be extended to a map $\Phi: G \times S^* \rightarrow S^* \times G$ by $\Phi(g, uv) = (u'v', g'')$ whenever $\Phi(g, u) = (u', g')$ and $\Phi(g', v) = (v', g'')$, and $\Phi(g, \epsilon) = (\epsilon, g)$ for $\epsilon \in S^*$ the empty word; then the action $g(v)$ is the first coordinate of $\Phi(g, v)$.

A fundamental example is afforded by the infinite cyclic group $G = \langle t \rangle$ and $S = \{0, 1\}$, with

$$\begin{aligned} \Phi(t^{2n}, 0) &= (0, t^n), & \Phi(t^{2n}, 1) &= (1, t^n), \\ \Phi(t^{2n+1}, 0) &= (t^n, 1), & \Phi(t^{2n+1}, 1) &= (t^{n+1}, 0). \end{aligned}$$

We shall return regularly to this example, called the *Kakutani–von Neumann odometer*.

The self-similarity map Φ may conveniently be viewed as a graph, with vertex set G and an edge from $g \in G$ to $h \in G$ labelled ' $s|t$ ' whenever $\Phi(g, s) = (t, h)$. Then the action of G on $S^{\mathbb{N}}$ is understood as follows: for $g \in G$ and $\xi \in S^{\mathbb{N}}$, find the unique right-infinite path in the graph that starts at g and has ξ as the left components of its labels. Then $g(\xi)$ is the word read on the right components of the labels along that same path. This graph is called the *full transducer* of the self-similar group.

A self-similar group is called *recurrent* if the map $\Phi: G \times S \rightarrow S \times G$ is onto. This implies, in particular, that the action of G is transitive on S^n for all $n \in \mathbb{N}$. A self-similar group is *contracting* if there exists a finite subtransducer N of the full transducer such that every path is eventually contained in N . We indifferently use N for the subtransducer or the corresponding subset of G . The minimal such N is called the *nucleus* of the action. Note that the identity necessarily belongs to N , since $\Phi(1, s) = (s, 1)$ for all $s \in S$. Following Bondarenko and Nekrashevych [7, Definition 5.1], a contracting self-similar group is *post-critically finite*, a.k.a. *bounded*, if its nucleus contains only a finite

number of left-infinite paths not ending at the identity. The *post-critical set* of G is the set P of left-infinite words read as inputs along these paths. In the example of the odometer, the nucleus is

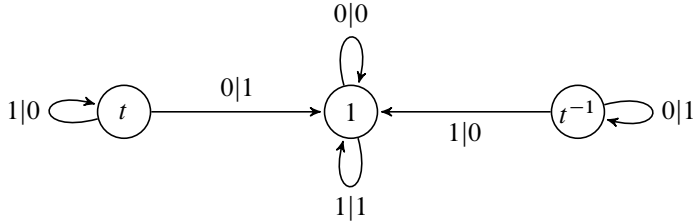

and the post-critical set is $P = \{\infty 0, \infty 1\}$.

Proposition 3.1 ([18, Proposition 2.11.3]). *Let G be a self-similar, contracting, finitely generated, recurrent group. Then G is generated by its nucleus.* ■

Let G be a contracting self-similar group with alphabet S and nucleus N , and recall the following fundamental construction by Nekrashevych: define

$$L(G) = S^{-\mathbb{N}} / (w \sim w' \Leftrightarrow \exists (g_n) \in N^{-\mathbb{N}} \text{ with } \Phi(g_n, w_n) = (w'_n, g_{n+1}) \forall n < 0).$$

Then $L(G)$ is a topological space called the *limit space* of G , and the dynamical system on $L(G)$ induced by the shift map on $S^{-\mathbb{N}}$ lies in a duality relation with G . Note that $L(G)$ in fact admits an orbispace structure, with finite isotropy groups (the isotropy group of $w \in S^{-\mathbb{N}}$ consists of all $(g_n) \in N^{-\mathbb{N}}$ such that $\Phi(g_n, w_n) = (w_n, g_{n+1})$ for all $n < 0$), and that the duality between self-similar groups and expanding dynamical systems holds only when this orbispace structure is taken into account. We choose to ignore it here, and again refer to [18] for details and extra information; in particular, the limit space $L(G)$ is compact, metrizable, has finite topological dimension, and is connected as soon as G is recurrent. Define next

$$T(G) = S^{-\mathbb{N}} / (w \sim w' \Leftrightarrow \exists (g_n) \in N^{-\mathbb{N}} \text{ with } \Phi(g_n, w_n) = (w'_n, g_{n+1}) \forall n < 0 \text{ and } g_0 = 1).$$

Following [18, §3.3], we call $T(G)$ the *digit tile*, noting that $L(G)$ is naturally a quotient of $T(G)$. Note that $T(G)$ is a topological space, i.e., it has no singular orbispace points. There are natural maps $F_s: T(G) \rightarrow T(G)$ induced by the maps $w \mapsto ws$ on $S^{-\mathbb{N}}$. More generally, for a word $v \in S^*$ we let $T_v(G)$ be the image of $S^{-\mathbb{N}}v$ in $T(G)$. Still in the example of the odometer, the limit space $L(G) = [0, 1]/(0 \sim 1)$ is the circle, with expanding self-covering induced by $f(x) = 2x \pmod 1$; and the digit tile $T(G) = [0, 1]$ is the interval, with contractions $F_i(x) = (x + i)/2$.

We connect the definitions of Kigami and Nekrashevych as follows. Let G be a post-critically finite self-similar group, with post-critical set $P \subset S^{-\mathbb{N}}$. Set $U = P$ and

$$V = (PS) / (u \sim v \Leftrightarrow \text{there is a path in the nucleus } N, \text{ ending at } 1, \text{ with labels } u|v);$$

note that we have $U \subseteq V$ and maps $G_s: U \rightarrow V$ given by $p \mapsto [ps]_{\sim}$ for all $s \in S$.

Proposition 3.2. *If G is a post-critically finite self-similar group, then $(V, U, \{G_s\}_{s \in S})$ is an ancestor structure, and the corresponding self-similar structure (K, S) is homeomorphic to the digit tile of G .*

Proof. It is easy to check the axioms $V = \bigcup_{s \in S} G_s(U)$ and $G_s(U) \setminus U \neq \emptyset$ for all $s \in S$ if $U \neq \emptyset$. It then suffices to note that the construction of (K, S) from an ancestor structure coincides with the construction of $T(G)$. Following the definitions, the non-trivial equivalence classes A_x are, for $x \in V$,

$$A_x = \{(w_n) \in S^{-\mathbb{N}} : \exists(x_n) \in U^{-\mathbb{N}} : G_{w_n}(x_n) = x_{n+1} \ \forall n \leq -2 \text{ and } G_{w_{-1}}(x_{-1}) = x\} \\ = \{w \in S^{-\mathbb{N}} : [w]_{\sim} = x\}.$$

Thus the equivalence relation constructing K from (V, U, S) identifies two left-infinite words w, w' precisely when there exists a left-infinite path in the nucleus N with label $w|w'$ and ending at 1, and this is the equivalence relation constructing the digit tile. ■

Proposition 3.3. *Let G be a critically finite self-similar group, and let (K, S) be its associated self-similar structure. Consider a ray $\xi \in S^{\mathbb{N}}$ and the Schreier graph of the orbit $G \cdot \xi$ with the nucleus of G as generating set. Then the tile adjacency graph $\Gamma(w)$ is the simple graph associated with the Schreier graph: the graph obtained by removing all loops and combining multiple edges.*

Proof. Since both the Schreier graph and the tile adjacency graph are inductive limits, it suffices to check the statement for the following two graphs: the tile adjacency graph Γ_n describing intersections of tiles K_v with $v \in S^n$, and the graph obtained from the Schreier graph of the action of G on S^n , in which loops are removed, multiple edges are combined, and edges labelled $g \in N$ from $u \in S^n$ to $v \in S^n$ are removed if $\Phi(g, u) = (v, h)$ with $h \neq 1$.

Now, in the latter graph, the remaining edges are edges labelled $g \in N$ from $u \in S^n$ to $v \in S^n$ with $\Phi(g, u) = (v, 1)$, so there is a path in the nucleus N starting at g and ending at 1 with label $u|v$; so u, v are respectively of the form $u'w$ and $v'w$ with u', v' suffixes of critical left-infinite words and some word w . Therefore the tiles K_u and K_v intersect.

Conversely, if $u, v \in S^n$ are such that the tiles K_u, K_v intersect, then $u = u'w$ and $v = v'w$ for some word w and suffixes u', v' of critical left-infinite words. There is then a left-infinite path in the nucleus whose label ends in $u'|v'$, so there exists $g \in N$ with $\Phi(g, u') = (v', 1)$; thus $g \cdot u = v$ and there is an edge in the Schreier graph from u to v . This completes the proof. ■

4. Decidability results

The main result of this section is that Schreier graphs of post-critically finite self-similar groups acting on orbits of rays have decidable domino problem and, if the ray is ultimately periodic, decidable monadic second-order theory. Note that there is one Schreier graph

per ray $\xi \in S^{\mathbb{N}}$, and all these graphs are non-isomorphic as rooted graphs – so there are continuously many different graphs. However, they all have the same collection of balls, and therefore the same answers to a given tiling problem, except in case ξ is ultimately periodic with same period as a post-critical ray. The monadic second-order theories of different Schreier graphs typically differ, so all but countably many may have decidable theory. Presumably the monadic second-order logic of the Schreier graph $G\xi$ is decidable whenever the ray ξ is computable.

4.1. The Sierpiński gasket

We start by a paradigmatic post-critically finite self-similar group and its associated Schreier graphs. The Sierpiński gasket is ubiquitous in discussions on fractals and graphs, and this text shall not be an exception. A remarkably simple transducer produces the gasket as its digit tile, and the associated graphs as Schreier graphs, see [10]:

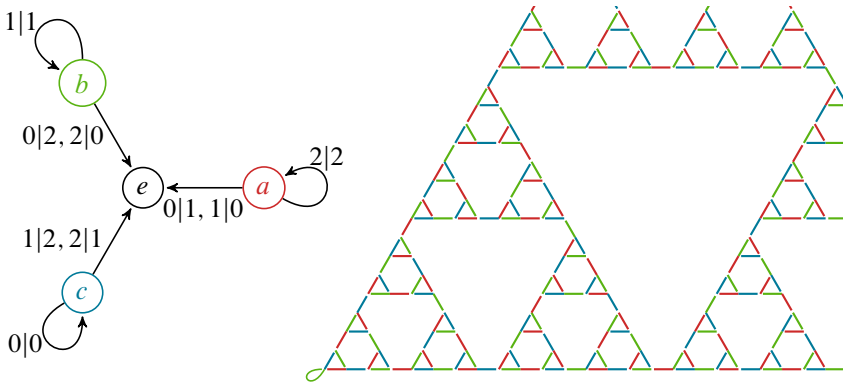

The group $\langle a, b, c \rangle$ is known as the “3-peg Hanoi tower group”, since its Schreier graph is well-known to be related to solutions to the Hanoi towers puzzle: if one encodes by a string $s_1 \dots s_n \in \{0, 1, 2\}^n$ a configuration in which disk number i (numbered from smallest to largest) is on peg s_i , then generators a, b, c correspond to moving the top disk respectively between pegs 0 and 1, 0 and 2, or 1 and 2.

4.2. The domino problem

We begin with the domino problem, for which a direct argument is possible:

Proposition 4.1. *Let G be a post-critically finite self-similar group acting on $S^{\mathbb{N}}$, let $\xi \in S^{\mathbb{N}}$ be a ray, and let Γ be the Schreier graph of the orbit $G\xi$ with respect to the nucleus of G . Then the domino problem on Γ is decidable.*

Proof. We shall give an algorithm that decides the domino problem. To fix notation, let N denote the nucleus of G , and let $P \subset S^{-\mathbb{N}}$ denote the post-critical set of G .

Let $\Theta \subseteq B \times N \times B$ be an instance of the domino problem for Γ .

Consider for all $n \in \mathbb{N}$ the “tile Schreier graph” Γ_n obtained from the action of G on S^n : the vertex set is S^n , and there is an edge from v to w labelled $g \in N$ whenever $\Phi(g, v) = (w, 1)$. It is a subgraph of the usual Schreier graph of the action of G on S^n . Let P_n denote the collection of length- n suffixes of post-critical words. Note that the vertices in Γ_n that have fewer than $\#N$ neighbours are precisely those in P_n .

Let Λ_n denote the set of restrictions to P_n of valid colourings of Γ_n ; more precisely, Λ_n is the subset of B^{P_n} consisting of all $\lambda: P_n \rightarrow B$ such that the colouring via λ of P_n can be extended to a valid colouring of Γ_n . Clearly $P_0 = \{\epsilon\}$ and $\Lambda_0 = B^{P_0}$.

Let us consider now how to compute Λ_{n+1} from Λ_n . Start with a collection of $\#S$ colourings $(\lambda_s)_{s \in S}$ of Γ_n , and use λ_s to colour $P_n s \subset \Gamma_{n+1}$. Keep only those colourings that match on their inner edges: for all $p \in P_n$, consider all $g \in N$ with $\Phi(g, p) \notin S \times \{1\}$, and then for all $s \in S$ write $\Phi(g, ps) = (qt, h)$; if $h = 1$, require $(\lambda_s(p), g, \lambda_t(q)) \in \Theta$, while if $h \neq 1$, then $ps \in P_{n+1}$, and set $\lambda(ps) = \lambda_s(p)$. We have in this manner defined a function $\lambda: P_{n+1} \rightarrow B$. Let Λ_{n+1} be the collection of all the functions λ that can be obtained in this manner.

Note that all post-critical points $p = \dots p_{-2}p_{-1} \in P$ are pre-periodic. Therefore, for n large enough, we have $\#P_n = \#P$ and there is a canonical bijection between P_n and P . Furthermore, for all $g \in N$ we have $\Phi(g, p_{-n} \dots p_{-1}) = (q_{-n} \dots q_{-1}, h)$ for a post-critical point $\dots q_{-2}q_{-1}$, and h depends only on the value of n modulo ℓ for some least common period ℓ of all post-critical points. Therefore, for n large enough, the spaces of maps B^{P_n} and $B^{P_{n+\ell}}$ are canonically in bijection, and the map $\Lambda_n \mapsto \Lambda_{n+1} \mapsto \dots \mapsto \Lambda_{n+\ell}$ only depends on $n \bmod \ell$; the “ n large enough”, modulus ℓ and map $\tau: \Lambda_{n\ell} \mapsto \Lambda_{(n+1)\ell}$ may all be computed from the nucleus. Since B and N are finite, τ is an ultimately periodic map on the family of subsets of $B \times N \times B$.

There are now two possibilities. Either τ eventually reaches the empty set, in which case there is no valid tiling of Γ ; or τ eventually cycles along non-empty sets, in which case there exist valid tilings of Γ_n for all n .

This last case is subdivided into two. Either the ray ξ is regular, and then Γ is an ascending union of copies of Γ_n , so it is tileable; or the ray ξ is singular, namely is ultimately periodic with same period p as a post-critical point ${}^\infty p \in P$. Then without loss of generality $\xi = p^\infty$, and the tiling of Γ is obtained from a limit of tilings of Γ_n by checking that, for n large enough so that the cycle of τ is attained, at least one colouring $\lambda \in \Lambda_n$ is valid at ξ ; assuming without loss of generality that n is divisible by $|p|$, this will hold precisely when $(\lambda(p^{n/|p|}), g, \lambda(g(p^{n/|p|}))) \in \Theta$ for all $g \in N$ with cycle p , namely with $\Phi(g, p) = (q, g)$. Again this requires a finite amount of checking. ■

4.3. Monadic second-order logic

Consider the elementary spaces of tilings X_Θ and X_{Θ, b_0} on a rooted graph (Γ, x_0) , the latter being the solution set of a seeded domino problem with colour b_0 at the root x_0 . The Γ -regular languages are those spaces of colourings of Γ obtainable from elementary ones by boolean operations (intersection, complement) and projections from a set of colours

to another; and $\text{Mon}(\Gamma)$ is decidable if and only if the emptiness problem for Γ -regular languages is decidable [17, Theorem 3.1]. It might be possible to prove decidability of $\text{Mon}(\Gamma)$ by extending the proof above to boolean expressions and projections; but this seems difficult. We shall prove the following theorem by an entirely different method.

Theorem 4.2. *Let G be a post-critically finite self-similar group acting on $S^{\mathbb{N}}$, let $\xi \in S^{\mathbb{N}}$ be an ultimately periodic ray, and let Γ be the Schreier graph of the orbit $G\xi$ with respect to the nucleus of G . Then the monadic second-order theory of the rooted graph (Γ, ξ) is decidable.*

In fact, we shall prove something stronger, namely G need only be a post-critically finite inverse semigroup of partially-defined bijections of $S^{\mathbb{N}}$.

Proof. We begin by straightforward reductions: up to replacing S by a power of itself, we may assume without changing Γ that ξ is ultimately constant. By enlarging G , we may assume that a constant ray $(s_0)^\infty$ is in the orbit $G\xi$. A monadic second-order formula then expresses $(s_0)^\infty$ in terms of ξ and vice versa, so we may assume that ξ is the constant ray $(s_0)^\infty$. By the same token, we may also assume that the generators of G have a very specific form, which we will make explicit later.

The first step is to encode the vertices of Γ . We shall view them as leaves of a tree, whose level- n vertices are $\sigma^n(G\xi)$. More precisely, the vertex set of the tree T is

$$\bigsqcup_{n \geq 0} \sigma^n(G\xi) \times \{n\},$$

and there is an edge labelled s from $(s\eta, n)$ to $(\eta, n + 1)$ for all $s\eta \in \sigma^n(G\xi)$. Thus T is an S -labelled tree, rooted at s_0^∞ .

I claim that $\text{Mon}(T)$ is decidable. Indeed consider first the tree T_0 of prefixes of the set of words $\{a^n b c^{n-1} : n \geq 1\} \cup \{\epsilon\}$. This is the set of total states of a push-down automaton, so $\text{Mon}(T_0)$ is decidable by the main result of [17]. We then apply the finite, regular mapping $a \mapsto s_0, b \mapsto (S \setminus \{s_0\})^{-1}, c \mapsto S^{-1}$ to obtain an S -labelled graph (with some of the labels written in reverse as s^{-1}) isomorphic to T . Since regular mappings preserve decidability [8], the claim is proven.

We next show how the Schreier graph Γ may be interpreted in T . First, it will be convenient to define successors, independently of the S -labelling:

$$\text{succ}(v, w) \equiv \bigvee_{s \in S} s \cdot v = w.$$

Vertices of Γ are leaves of T , and are thus characterized by the formula

$$\text{leaf}(v) \equiv \neg \exists w [\text{succ}(w, v)].$$

Given a monadic predicate ϕ satisfied by a set X , one may consider a predicate characterizing the minimal such X , namely

$$\phi^{\min}(X) \equiv \phi(X) \wedge \forall Y [\phi(Y) \Rightarrow X \subseteq Y].$$

If ϕ takes the form ‘ $\exists X \dots$ ’, we simply write ϕ^{\min} as ‘ $\exists^{\min} X \dots$ ’.

Every leaf (or even vertex) of T has a unique ray, obtained by following edges in S : the ray R of v is characterized by

$$\text{ray}(v, R) \equiv (v \in R \wedge (\forall w \in R [\exists x \in R [\text{succ}(w, x)]])^{\min},$$

namely it is a minimal set containing v and in which every element has a successor. In particular, the order in the tree may be defined by

$$(v \leq w) \equiv \forall Q, R [\text{ray}(v, Q) \wedge \text{ray}(w, R) \wedge R \subseteq Q].$$

The first symbol of the word coding a vertex v is given by predicates

$$\text{head}_s(v) \equiv \exists w [s \cdot v = w] \text{ for all } s \in S.$$

Finally, we consider predicates stating that a ray, or portion of ray, has a given constant label:

$$\text{const}_q(R) \equiv \forall x \in R [\text{head}_q(x)] \text{ for all } q \in S.$$

Up to replacing S by a power of itself, as we did in the very first step, we may assume that every generator of G is a disjoint union (as a relation) of elementary partial bijections, obtained as follows:

- (1) The identity is elementary.
- (2) If g is elementary and $s, t \in S$, then the partial bijection h supported on $sS^{\mathbb{N}}$ and defined by $\Phi(h, s) = (t, g)$ is elementary.
- (3) If g is elementary and $q, r, s, t \in S$ with $q \neq s$ and $r \neq t$, then the partial bijection h defined by $\Phi(h, s) = (t, g)$ and $\Phi(h, q) = (r, h)$ is elementary.

Indeed the transducer of a bounded transformation of $S^{\mathbb{N}}$ consists of a finite collection of cycles, reached by finite paths, and leading to the identity. The cycles can be assumed to be loops, and each transition to the identity is considered separately.

We prove, by induction, that every elementary partial bijection may be encoded by a monadic second-order formula. This is obvious for the identity transformation, which is coded as

$$\text{id}(v, w) \equiv (v = w).$$

Assume that g is elementary, so there is a formula for g , and consider h with $\Phi(h, s) = (t, g)$. Then a formula for h is

$$h(v, w) \equiv \text{head}_s(v) \wedge \text{head}_t(w) \wedge \text{succ}(v, v') \wedge \text{succ}(w, w') \wedge g(v', w').$$

All these operations only require first-order logic. For the last case, assume that there is a formula for g , and that h is defined by $\Phi(h, s) = (t, g)$ and $\Phi(h, q) = (r, h)$. Then h may be defined by the following formula:

$$\begin{aligned}
 h(v, w) \equiv \exists P, Q, R \Big[& \text{ray}(v, Q) \wedge \text{ray}(w, R) \wedge P = Q \cap R \\
 & \wedge \left((P = \emptyset \wedge \text{const}_q(Q) \wedge \text{const}_r(R)) \right. \\
 & \left. \vee \left(\exists x \in P [\neg \exists y \in P [\text{succ}(y, x)]] \wedge \exists v' \in Q, w' \in R \right. \right. \\
 & \left. \left. [s \cdot v' = x = t \cdot w' \wedge \text{const}_q(Q \setminus P \setminus \{v'\}) \wedge \text{const}_r(R \setminus P \setminus \{w'\})] \right) \right].
 \end{aligned}$$

The meaning is the following: P is the common suffix of the words encoding v, w . If these words have empty common suffix, then they must respectively be q^∞ and r^∞ . Otherwise, they must respectively have the form q^*sP and r^*tP .

Since we can interpret the action of the generators of G in $\text{Mon}(T)$, which is decidable, it follows that $\text{Mon}(\Gamma)$ is decidable as well. ■

4.4. Treewidth

Let Γ be a graph. A *tree decomposition* of Γ is a tree Δ with, for each vertex $v \in V(\Delta)$, a subset $X_v \subseteq V(\Gamma)$ called a *bag*, subject to two axioms:

- (1) For every $v \in V(\Gamma)$ the set of bags containing v spans a non-empty subtree of Δ .
- (2) For every $e \in E(\Gamma)$ there is a bag containing $\{e^+, e^-\}$.

The *width* of a tree decomposition is one less than the supremum of the bag sizes, and the *treewidth* of Γ is the minimal width of a tree decomposition. (The “one less” is purely aesthetic, and implies that trees have treewidth 1.)

Decidability of the monadic second-order theory of graph implies that its treewidth is bounded [21]; but this can be proven directly:

Proposition 4.3. *Let Γ be the Schreier graph of a post-critically finite group acting on the orbit of a ray. Then the treewidth of Γ is finite.*

We shall actually give a computable bound on the treewidth: let $G\xi$ be the vertex set of Γ , let P be the post-critical set of G , let S be its alphabet, and in the transducer defining G let p, q be respectively the maximal length of a path leading from a generator to a cycle and from a cycle to the identity. Then the treewidth is at most $\#P \cdot \#S^{p+q}$.

Proof. As in the proof of Theorem 4.2, let Δ be the following tree: its vertex set is $\bigsqcup_{n \geq 0} \sigma^n(G\xi) \times \{n\}$, and there is an edge between (η, n) and $(\sigma(\eta), n + 1)$. The bag at (η, n) is

$$\begin{aligned}
 X_{(\eta, n)} = \{ & uvw\sigma^{p+q}(\eta) : |u| = p \text{ and } v \text{ is the length-}n \text{ suffix of a} \\
 & \text{post-critical ray} \in P \text{ and } |w| = q \} \cap G\xi.
 \end{aligned}$$

The cardinality estimate is obviously satisfied, and the bags containing any given $\eta \in G\xi$ form a $\#S$ -regular rooted subtree of Δ . Furthermore, every edge of Γ , say with label

$g \in G$, connects $uvw\eta$ to $u'v'w'\eta$ where v is the suffix of a post-critical ray: $\Phi(g, u) = (u', h)$ where h lies on a cycle or is already finitary, $\Phi(h, v) = (v', k)$ with k finitary, and $\Phi(k, w) = (w', 1)$. ■

5. Undecidability results

We now prove that the domino problem is undecidable on some examples of self-similar graphs. The method of proof is uniform: simulate a grid within the graph; then, since machines may be simulated on grids, we see that the graph in question is capable of universal computation, and therefore has undecidable domino problem.

Let Γ be an A -labelled graph. By “simulating a grid in Γ ” we mean the following: there is a grid Δ , and a domino problem Θ_{simul} for Γ that marks some vertices in Γ as representing vertices of Δ , and some sequences of edges in Γ as representing edges of Δ .

More precisely, assume Δ is B -labelled. Every colouring of Γ given by Θ_{simul} must have the following feature: it distinguishes some of the vertices of Γ as being “ Δ -vertices”, and assigns to each edge of Γ a set of signals in $\{0, 1\} \times B \times \{0, 1\}$. It is required that Δ be isomorphic to the graph with the collection of Δ -vertices as vertex set and having an edge labelled b for every path in Γ coloured $(0, b, 1) \cdots (1, b, 1) \cdots (1, b, 0)$ that joins Δ -vertices. For details see [3, §2].

If Δ has unsolvable domino problem, then so does Γ : indeed given any instance of a domino problem on Δ , it may be combined with the domino problem Θ_{simul} so as to produce a domino problem for Γ ; if that last problem were solvable, so would be the original one.

If Δ is the subgraph of Γ consisting of all A' -labelled edges, for some subset $A' \subset A$, then Δ is simulated by Γ . This was exploited for example in [11] to prove that every group containing a direct product of two infinite, finitely generated subgroups has unsolvable domino problem. However, the examples we consider here are graphs that do not contain any grid as a subgraph.

Conversely, if Γ simulates Δ , then Δ is (up to duplicating the vertices and edges of Γ by a finite amount) a minor of Γ . However, our definition of simulation requires some amount of regularity (in the sense of regular languages) in the extraction of the minor from Γ .

In more detail: we first reduce the *seeded* domino problem on Γ to that of a grid, by constructing a tiling that, when properly seeded, exhibits a grid as a minor of Γ . It seems impossible to avoid the seed, since the grid will necessarily be quite sparse in Γ , and in particular will ignore arbitrarily large balls. We then show, using a sunny-side-up tiling, that the seed may be distinguished by an (unseeded) tiling. The (unseeded) domino problem is then equivalent to the seeded one, by Lemma 2.3.

The precise implementation of this plan depends on the graph, and I will carry it out for two examples of self-similar graphs that seem at the border of decidability/undecidability. The second one is essentially equivalent to the subgraph of \mathbb{Z}^2 considered in [2, Fig. 1,

middle]. In each case, a simulation has to be defined *ad hoc*, and I will not attempt to make any general claim.

5.1. The long range graph

Consider the graph with vertex set \mathbb{Z} , and two kinds of edges: for all $n \in \mathbb{Z}$ an edge between n and $n + 1$; and for all $m \in \mathbb{Z}$, $s \in \mathbb{N}$ an edge between $2^s(2m - 1)$ and $2^s(2m + 1)$ with additionally a loop at 0. It is known as the “long range graph”, a deterministic avatar of long-range percolation [20]. It is one of the simplest examples of “ ω -periodic graphs” considered in [4], see also [6].

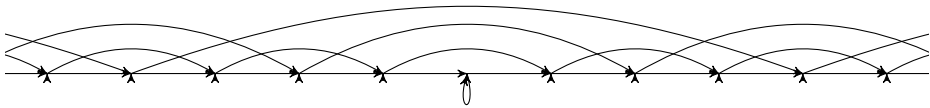

This graph Γ is the Schreier graph $G \cdot 0^\infty$ of a self-similar group given by the following transducer:

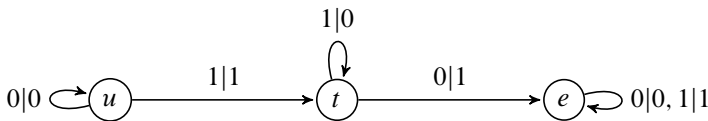

Indeed identify \mathbb{Z} with all infinite words in $\{0, 1\}^\infty$ ending in 0^∞ or 1^∞ , via the binary expansion of integers. Then the edges given by generator t connect n to $n + 1$, while generator u connects $2^s(2m - 1)$ to $2^s(2m + 1)$. Set $A = \{t, u\}$.

Proposition 5.1. *There are a tilingset $\Theta_0 \subset B_0 \times \{t, u\} \times B_0$ and a colour $b_0 \in B_0$, such that X_{Θ_0} contains a unique tiling τ with $\tau(0) = b_0$; and this tiling simulates a grid.*

Proof. We use dominoes to impose successively more colourings on Γ ; the colours combine, so that each vertex will have many different colours at the end of the process. We are in fact imposing a sequence of domino colourings on Γ , with each one making use of the previous colours.

- (1) We first mark 0 with a special colour 0 (this is specified by the seed colour b_0).
- (2) We mark all positive integers by +, and all negative ones by -. This is done by choosing $B_1 = \{0, +, -\}$ and $\Theta_1 = \{(-, t, -), (-, t, 0), (0, t, +), (+, t, +)\} \cup (B_1 \times \{u\} \times B_1)$.
- (3) We mark all powers of 2 by p . This is done by selecting all vertices marked + and whose u^{-1} -neighbour is marked -: choose $B_2 = B_1 \times \{p, \sqcup\}$ and

$$\Theta_2 = \{((b, c), a, (b', c')) : ((b, a, b') = (-, u, +)) \Leftrightarrow (c' = p)\}.$$

- (4) Mark all strips of integers between powers of 2 as e (even) or o (odd), starting with $-\mathbb{N}$ marked as e . This is done by setting $B_3 = B_2 \times \{e, o, p_e, p_o\}$, forcing 0 to be marked e , copying the p marks from B_2 as p_e or p_o , and forbidding patterns (e, t, o) , (o, t, e) , (e, t, p_o) , (o, t, p_e) , (p_e, t, e) and (p_o, t, o) in the new layer.
- (5) Mark all integers of the form $2^n + 2^m$, for $n > m$, as q . This is done by setting $B_4 = B_3 \times \{q, \sqcup\}$, and (just as we marked before the powers of 2) marking by q all integers having a different parity (e/o) than their u^{-1} -neighbour.

The construction above clearly comes from a finite collection $\Theta_0 \subset B_0 \times \{t, u\} \times B_0$ of dominoes, which produces the specified marks as unique colouring.

The vertices marked by a q form a grid, more precisely an octant $\{(n, m) : n > m\}$, with (n, m) represented as $2^n + 2^m$. It remains to show how the neighbourhood relation in this octant can be realized. The edge between (n, m) and $(n \pm 1, m)$ is realized by: starting from a q -marked vertex, follow $u^{\pm 1}$ to the next q -marked vertex. The edge between (n, m) and $(n, m \pm 1)$ is realized by: starting from a q -marked vertex, follow $t^{\pm 1}$ to the next q -marked vertex. ■

The reduction of the tiling problem on the octant to the seeded tiling problem on Γ may be seen quite explicitly as follows: given an instance $\Theta \subseteq B \times \{S, E, N, W\} \times B$ of the domino problem on the octant, construct a multi-layered domino problem on Γ : each vertex has one colour in B_0 and two colours in B , one for the vertical direction and one for the horizontal one. The domino rules impose that the colour in B_0 marks q -vertices as above; that non-marked vertices propagate their horizontal colour along u -edges and their vertical colour along t -edges; and that q -marked vertices check that the propagated vertical and horizontal colours match Θ .

Note that the octant does not have vertices (n, n) , so there is no vertical edge from $(n, n - 1)$ to (n, n) . The domino tiling on the octant ignores the N direction at $(n - 1, n)$, as likewise the domino rules propagating colours vertically may be required to ignore their constraint as they cross through a vertex marked p .

The graph Γ is highly intransitive: the origin 0 is the unique vertex having a loop labelled u . We use this feature to distinguish it among all other vertices:

Proposition 5.2. *The sunny-side-up S_0 is sofic on Γ .*

Proof. Choose as colours $B = \{0, -_0, -_1, +_0, +_1\}$, and consider the tileset

$$\Theta = \{(-_\sigma, t, 0), (0, u, 0), (0, t, +_\tau), (\delta_\sigma, t, \delta_\tau), (\delta_\sigma, u, \varepsilon_{1-\sigma}) : \delta, \varepsilon \in \{\pm\}, \sigma, \tau \in \{0, 1\}\}.$$

Then at most one vertex of Γ may be coloured 0: all its neighbours in the t direction are coloured $\{+_0, +_1\}$, and all its neighbours in the t^{-1} direction are coloured $\{-_0, -_1\}$. This vertex coloured 0, if it exists, must be the origin because its u -neighbour is also coloured 0. On the other hand, the origin has to be coloured 0, since all u -edges have distinct colours at their extremities if they are not 0.

It remains to see that X_Θ is not empty. The colouring in which 0 is coloured 0 and $2^s(2m + 1)$ is coloured $\text{sign}(m - \frac{1}{2})_{m \bmod 2}$ is legal. ■

We are ready to put the pieces together:

Proof of Theorem B. We invoke the classical fact that the domino tiling is undecidable on the octant [23]. By Proposition 5.1 the seeded domino problem is undecidable on Γ . By Proposition 5.2 and Lemma 2.3 the domino problem is equivalent to the seeded domino problem on Γ . ■

If the reader got the impression that the domino problem was deduced from the seeded domino problem using a cheap trick, it's because it's the truth: the orbit $G \cdot 0^\infty$ is special in that its position 0^∞ is marked by a u -loop. A more sophisticated argument would be required to study the domino problem on other orbits.

5.2. The Barbieri–Sablik H -graph

Our second example is a variant of a graph considered by Barbieri and Sablik [2] in their investigation of domino problems on self-similar structures, see Section 6. Consider the graph with vertex set $\mathbb{N} \times \mathbb{Z}$, and two kinds of edges: connecting (m, n) with $(m, n \pm 1)$; and connecting $(2^s m - 1, 2^s n)$ and $(2^s m, 2^s n)$ for all $s \geq 0, m \geq 1, n \in \mathbb{Z}$.

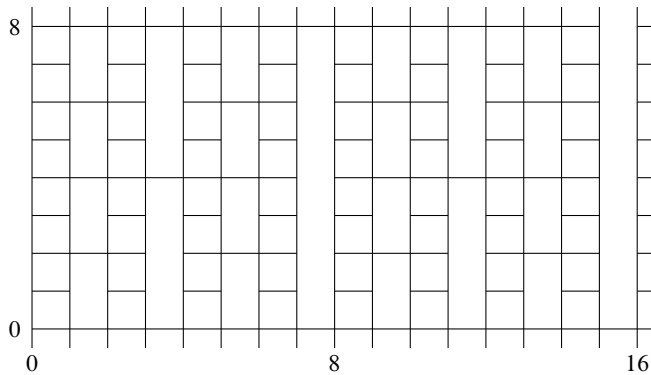

This graph is also the Schreier graph of a transducer group. In the transducer below, the alphabet S is $\{00, 01, 10, 11\}$ and ε takes all values in $\{0, 1\}$:

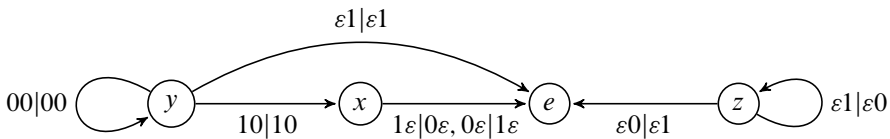

There is a natural bijection between $\mathbb{N} \times \mathbb{Z}$ and infinite words in $S^\mathbb{N}$ ending in $(00)^\infty$ or $(01)^\infty$: firstly, $S = \{0, 1\} \times \{0, 1\}$, so every sequence $w \in S^\mathbb{N}$ corresponds to a pair of sequences $(u, v) \in \{0, 1\}^\mathbb{N}$. Now, given $(m, n) \in \mathbb{N} \times \mathbb{Z}$, the pair of sequences representing it is (u, v) with u the Gray encoding of m , and v the binary encoding of n . Recall that the binary encoding of $n = \sum_{i \geq 0} v_i 2^i$, with almost all $v_i = 0$ or almost all $v_i = 1$, is

$v_0v_1 \dots$; and that the Gray encoding of $m = \sum_{i \geq 0} u_i 2^i$ is $(u_0 \oplus u_1)(u_1 \oplus u_2) \dots$ with \oplus the exclusive-or of bits $\in \{0, 1\}$. It is then clear that generator z connects

$$(u, 1^s 0 v_{s+1} \dots) \text{ to } (u, 0^s 1 v_{s+1} \dots)$$

and therefore (m, n) to $(m, n + 1)$; that generator x has order 2 and connects

$$(0u_1 \dots, v) \text{ with } (1u_1 \dots, v)$$

and therefore $(2m, n)$ with $(2m + 1, n)$; and that generator y also has order 2 and connects

$$(0^s 10 u_{s+2} \dots, 0^{s+1} v_{s+2} \dots) \text{ with } (0^s 11 u_{s+2} \dots, 0^{s+1} v_{s+2} \dots)$$

and therefore $(2^s(2m + 1) - 1, 2^{s+1}n)$ with $(2^s(2m + 1), 2^{s+1}n)$. This concludes the proof that the graph Γ is indeed the Schreier graph of the group $\langle x, y, z \rangle$. Set $N = \{x, y, z\}$, the nucleus of the group generated by $\{x, y, z\}$.

We shall first show that Γ simulates the ‘‘hyperbolic horoball’’. This is the graph Δ with vertex set $\{(2^{s+1} - 1, 2^s n) : s \geq 0, n \in \mathbb{Z}\}$, and with edges between $(2^{s+1} - 1, 2^s(2n))$ and $(2^{s+2} - 1, 2^{s+1}n)$ and between $(2^{s+1} - 1, 2^s n)$ and $(2^{s+1} - 1, 2^s(n + 1))$. It corresponds (after 90° rotation) to a tiling of the horoball $\{\Im(z) \geq 1\}$ in the hyperbolic plane by pentagons with Euclidean-straight sides and angles $(90^\circ, 90^\circ, 90^\circ, 90^\circ, 180^\circ)$.

Proposition 5.3. *The graph Γ , when rooted at $(0, 0)$, simulates the hyperbolic horoball.*

The hyperbolic horoball is drawn below in thick lines, on top of Γ (for which the generators x, y, z are drawn respectively in red, green, blue):

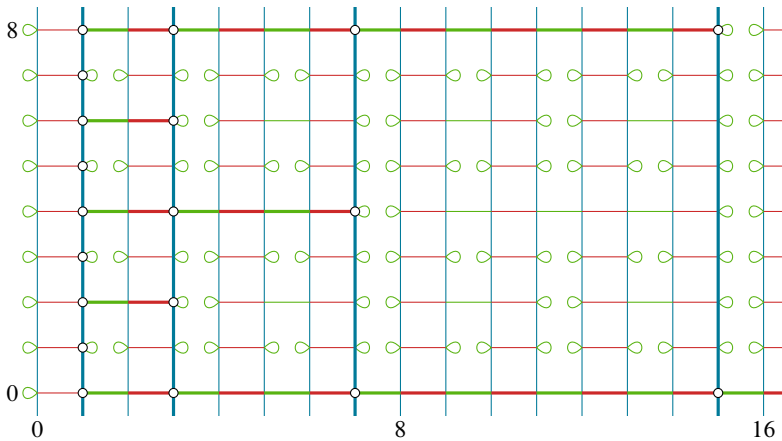

Proof. The representation of Δ as a subset of $\mathbb{N} \times \mathbb{Z}$ matches the representation of Γ , and we shall construct a domino problem whose unique solution is a marking that singles out the vertices of Δ along with its edges. Consider the set of colours

$$B_0 = \{a_0, a_1, b_0, \dots, b_4, c_0, c_1, c_2, d_0, d_1, d_2\},$$

the generating set $S = \{x, y, z\}$ and the tileset

$$\Theta_0 = \left\{ \begin{array}{ccccc} (a_0, x, b_0) & (b_0, x, c_0) & (c_0, x, d_0) & (a_1, x, b_1) & (a_1, x, b_2) \\ (b_1, x, c_1) & (b_2, x, c_1) & (c_1, x, d_1) & (b_3, x, c_2) & (b_4, x, c_2) \\ (c_2, x, d_2) & & & & \\ (a_0, y, a_0) & (b_0, y, c_0) & (c_0, y, d_0) & (a_1, y, a_1) & (b_1, y, c_1) \\ (b_2, y, b_2) & (c_1, y, d_1) & (b_3, y, b_3) & (b_4, y, b_4) & (c_2, y, c_2) \\ (c_2, y, d_2) & (d_2, y, d_2) & & & \\ (a_0, z, a_1) & (a_1, z, a_0) & (a_1, z, a_1) & (b_0, z, b_2) & (b_0, z, b_3) \\ (b_1, z, b_2) & (b_1, z, b_3) & (b_2, z, b_0) & (b_2, z, b_1) & (b_2, z, b_4) \\ (b_3, z, b_2) & (b_3, z, b_3) & (b_4, z, b_0) & (b_4, z, b_1) & (b_4, z, b_4) \\ (c_0, z, c_2) & (c_1, z, c_2) & (c_2, z, c_0) & (c_2, z, c_1) & (c_2, z, c_2) \\ (d_0, z, d_2) & (d_1, z, d_2) & (d_2, z, d_0) & (d_2, z, d_1) & (d_2, z, d_2) \end{array} \right\},$$

more conveniently given as the edges in the following graph:

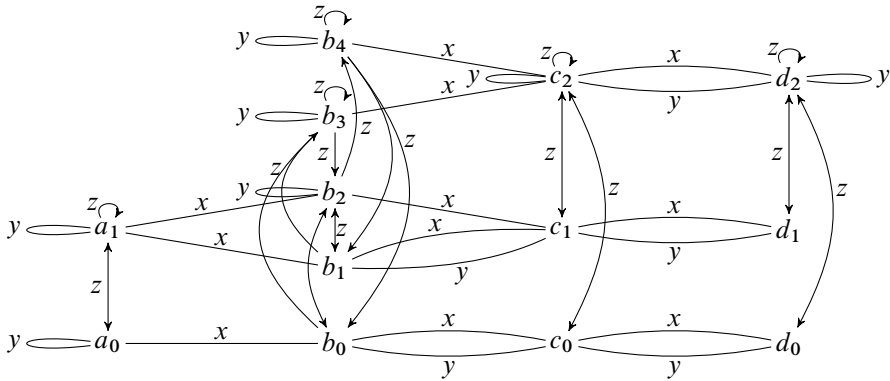

I claim that, if the origin $(0, 0)$ is coloured a_0 in a colouring respecting Θ_0 , then the nodes coloured b_0, b_1, b_2 constitute the vertices of the hyperbolic horoball Δ ; that horizontal edges are marked by following an arbitrary power of xy over vertices coloured $\{c_1, d_1\}$ till the next vertex of Δ is reached; and that vertical edges are marked by following an arbitrary power of z over vertices coloured $\{b_3, b_4\}$ till the next vertex of Δ is reached.

These claims follow from a series of ‘‘Sudoku’’ deductions. The rules first imply that the horizontal axis is coloured $a_0((b_0|d_0)c_0)^\infty$, and that all the colours on a vertical line share the same letter (a, b, c, d) . If any vertex along the vertical axis is coloured a_0 , then the corresponding row must also be coloured $a_0((b_0|d_0)c_0)^\infty$, so in particular it cannot contain any y loop. However, all rows at height $\neq 0$ contain such a y loop, so the vertical axis must be entirely coloured a_1 , except for the origin.

Now, if some vertex on the vertical axis is coloured a_1 , then the corresponding row is coloured $a_1((b_1|d_1)c_1)^*b_2c_2((d_2c_2)^*(b_3|b_4))^\infty$ with a b_2 at the position of the first y loop. Since this first loop appears at abscissa $2^{s+1} - 1$ for some $s \geq 0$, the columns $\{2^{s+1} - 1\} \times \mathbb{Z}$ are all coloured using $\{b_0, \dots, b_4\}$. In the upwards direction, they are

coloured $b_0(b_3^*b_2b_4^*b_1)^\infty$, and symmetrically downwards. Combining the conditions on the rows and columns, the colour of vertex $(2^{s+1} - 1, 2^s n)$ is b_0 if $n = 0$, is b_1 if n is even, and is b_2 if n is odd.

If furthermore $s > 0$, then along that column $\{2^{s+1} - 1\} \times \mathbb{Z}$ there are vertices coloured b_3 and b_4 , at $(2^{s+1} - 1, 2^{s-1}n)$ with n odd. These are connected by a sequence of x and y to $(2^s, 2^{s-1}n)$, along a horizontal segment coloured using $\{c_2, d_2\}$; so all columns $\{2m - 1\} \times \mathbb{Z}$ with $m > 0$ not a power of 2 are coloured using $\{d_0, d_1, d_2\}$.

The colouring is thus entirely specified by the dominoes, and the hyperbolic horoball appears exactly at the claimed position. Its vertices are connected, vertically, by sequences of b_3 or b_4 , and horizontally by sequences of c_1d_1 :

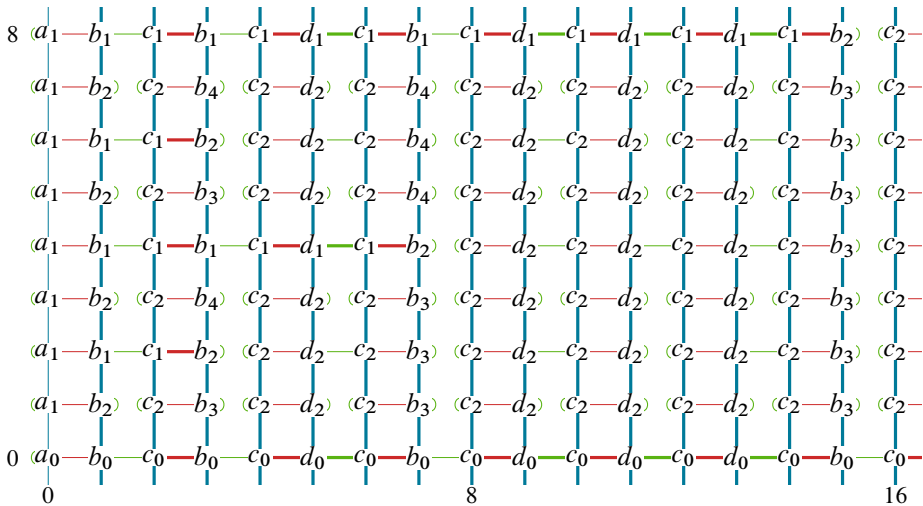

The proof of Proposition 5.3 is complete. ■

Since the hyperbolic grid has undecidable domino problem [13], so does the hyperbolic horoball; thus the seeded tiling problem is undecidable on Γ . In fact, we shall not need this, and rather reduce to the tiling problem on arbitrarily large strips.

Indeed the hyperbolic horoball separates strips of width 2^s between $2^s - 1$ and $2^{s+1} - 1$. These are the vertices coloured $b_0, \dots, b_4, c_0, c_1, d_0, d_1$ in the colouring by Θ_0 . Movement in this grid is defined exactly as in the hyperbolic horoball: follow either of x, y, z till a new marked vertex is reached.

Given an instance of the tiling problem for the plane, namely a set of Wang tiles $\Theta_1 \subseteq C^{\{S,E,N,W\}}$, we construct an instance of the seeded tiling problem on Γ as follows. The colours are $B_0 \times \Theta_1$; the legal edge colourings enforce the rules Θ_0 on the first coördinate; propagate the second coördinate in the z direction till a marked vertex is reached, at which point the N/S matching rules of Θ_1 are imposed; and impose the E/W matching rules of Θ_1 along x - and y -coloured edges:

$$\Theta = \{((p, \theta), g, (p', \theta')) : (p, g, p') \in \Theta_0, \\
g = z \wedge p' \in \{c_2, d_2, b_3, b_4\} \Rightarrow \theta' = \theta, \\
g = z \wedge p' \in \{c_0, c_1, b_0, b_1, b_2\} \Rightarrow (\theta')_S = \theta_N, \\
g = x \wedge p' \in \{c_0, c_1\} \Rightarrow (\theta')_E = \theta_W, \\
g = y \wedge p' \in \{d_0, d_1\} \Rightarrow (\theta')_E = \theta_W\}.$$

It is then clear that there is a valid colouring of Γ by Θ with first coördinate b_0 at the origin if and only if arbitrarily long strips of the right Euclidean half-plane can be coloured by Θ_1 .

Our next step would be to consider the sunny-side-up on Γ . Unfortunately:

Lemma 5.4. *The sunny-side-up on Γ is not sofic.*

Proof. Assume for contradiction that $S_{(0,0)}$ is sofic, and let $X_\Theta \rightarrow S_{(0,0)}$ be the factor map. Consider $\tau \in X_\Theta$, and define τ_s as the map $\mathbb{N} \times \mathbb{Z} \rightarrow B$ given by

$$\tau_s(m, n) = \tau(m + 2^s, n + 2^{s-1}).$$

By compactness, the τ_s have an accumulation point τ_∞ . Since the pointed labelled graphs $(\Gamma, (2^s, 2^{s-1}))$ converge to the pointed graph $(\Gamma, (0, 0))$, we have $\tau_\infty \in X_\Theta$, yet $\pi(\tau_\infty(0, 0)) \neq 1$ since it is a pointwise limit of $(0, 0, \dots)$. ■

We follow a slightly different strategy to prove that the domino problem is undecidable on Γ , which amounts to simulating the hyperbolic horoball without marking a root on Γ . We shall construct, in steps, a tiling that admits as single tiling a specific configuration of edge and vertex decorations in Γ , whose edges form a graph quasi-isometric to the tiling of the hyperbolic horoball by right-angled pentagons. We shall not directly write down the tiling Θ , but rather use more general patterns. This is of course equivalent thanks to Lemma 2.1.

Marking some segments. Vertices of Γ will be coloured using $\{\sqcup, 1, 2, 3, 4, 4'\}$; the colours 1, 2, 3, 4, 4' will mark all vertices with 4 neighbours, and \sqcup will mark the vertices with 3 neighbours.

- (1) We force every vertex marked by an integer (1, 2, 3, 4, 4') to have 4 neighbours. (This follows from Lemma 2.2, and is easily done by forcing each integer-marked vertex to have a different colour at its y -neighbour.)
- (2) By forbidding all patterns $\{1, z, xz, z^{-1}xz\} \rightarrow \{b, c\}^4$, we force every $\{v, zv, xzv, z^{-1}xzv\}$ to contain at least one integer mark.
- (3) We restrict the allowed integer combinations on endpoints of x - and y -edges:

$$(1, y, 1), \quad (2, y, 4), \quad (3, y, 3), \quad (4, y, 4'), \quad (3, x, 4), \quad (4, x, 4').$$

We force every column to be coloured $\sqcup^{\mathbb{Z}}$ or $(1\sqcup(2|4|4')\sqcup)^{\mathbb{Z}}$ or $(3\sqcup^+(4|4')\sqcup^+)^{\mathbb{Z}}$, where (as usual for regular expressions) \sqcup^+ denotes a sequence of at least one \sqcup ,

and $(4|4')$ denotes either 4 or $4'$. (This is easily enforced with dominoes by giving a different secondary colour to all $_$'s in the expressions above.)

By the second rule, every vertex in $\{2m, 2m + 1\} \times \{4n + 1, 4n + 2\}$ contains an integer; and the only vertices with 4 neighbours among these are $(4m + 1, 4n + 2)$ and $(4m + 2, 4n + 2)$. Furthermore, the x -neighbour of these vertices has 3 neighbours; so $(4m + 1, 4n + 2)$ and $(4m + 2, 4n + 2)$ must be coloured 1.

The vertices $(1, 4n)$ also have an x -neighbour with 3 neighbours, so they must be coloured 2 because of the alternation $(1, 2)$ on column 1.

The odd rows are then coloured $_N$; those at height $4n + 2$ are coloured $(__11)_N$; those at height $2^{s+1}(2n + 1)$ for some $s \geq 1$ are coloured $(__2(44')^{2^s-2}4334(4'4)^{2^s-2}__2)_N$; and the horizontal axis is coloured $_(44')_N$. This again easily follows from Sudoku deductions: because of the y -loop at $(2^{s+2} - 1, 2^{s+1}(2n + 1))$, the colours must start by an expression of the form $__2(44')^*42__$ with an odd number of 334 inserted in it, and because of the vertical alternation $(3, 4|4')$ the 33 may only occur at position $2^{s+1} - 1$ and 2^{s+1} :

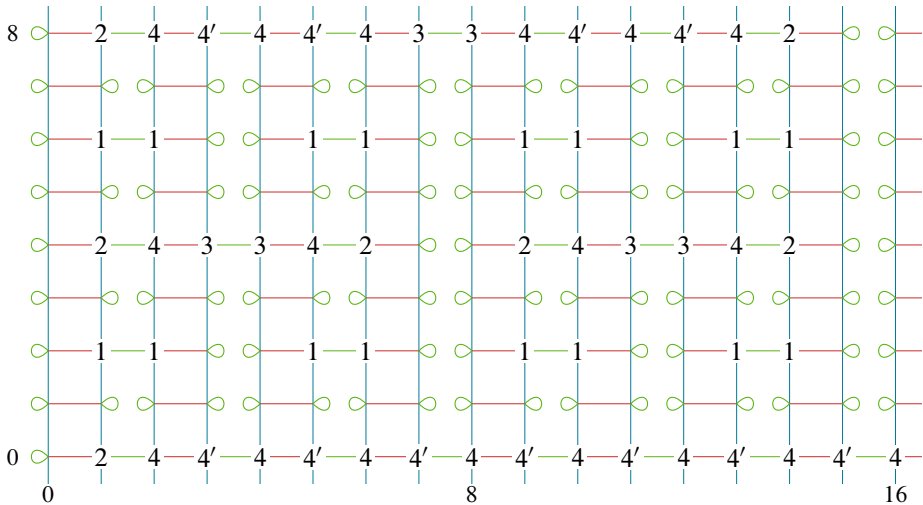

We now add orientations to some edges in Γ , to express flow of information; distinguish certain vertices; and define some edges between them.

Selecting vertices and edges. Vertices marked 1 or 3 always admit a y -neighbour with the same mark. The “distinguished vertices” we are interested in are the pairs of neighbours with identical odd mark. We call them *clusters*, and more precisely 1-clusters and 3-clusters.

We then add orientations to some edges. Every 1-cluster has a single outgoing arrow (among its 6 neighbours). This arrow must start an oriented path of length 4, labelled $z^{\pm 2}yx$ along its edges, and going through vertices marked 1, $_$, 2, 4, 3. After the $z^{\pm 2}$ it must run parallel with another path (coming from the 1 at position $z^{\pm 4}$ from the vertex at which the oriented path started).

Every 3-cluster has two incoming double-arrows, along x -labelled edges, and a single outgoing arrow. As above, this arrow must start an oriented path labelled $(z^{\pm 1})^*(yx)^*$ along its edges, and going through vertices marked $3, \square, \dots, \square, 4', 4, \dots, 4', 4, 3$. After the $(z^{\pm 1})^*$ it must run parallel with another path (coming from the 3 at position $(z^{\pm 1})^*$ from the vertex at which the oriented path started).

These sequences of arrows define “imaginary” paths between clusters. Additionally, the vertex from each cluster that does not have an outgoing arrow is connected by a “real” path labelled $(z^{\pm 1})^*$ along its edges, and going through vertices marked $\{1, 3\}, \square, \dots, \square, 4, \square, \dots, \square, \{1, 3\}$. (The terminology “real/imaginary” comes from directions in the upper half-plane $\{\Im(z) > 0\}$, that we shall use later.)

We first claim that the above rules can be enforced by dominoes. To check this, it suffices to note that every edge gets up to two arrows, and that local rules determine the claimed tiling.

We next claim that the rules enforce a unique configuration of arrows. Indeed out of every four 1-clusters at distance 4 from each other, at least one can reach a unique 3-cluster along $z^{\pm 2}yx$; and this forces the three other 1-clusters to be connected to the same 3-cluster. The same argument applies to each of these 3-clusters that were just connected to 1-clusters: for every quadruple of such 3-clusters, at least one of them will be connected to a unique 3-cluster along $(z^{\pm 1})^*(yx)^*$, and the other three in the quadruple will have to be connected to the same higher-level 3-cluster. This process can be carried on forever, resulting in a valid decoration of Γ with arrows:

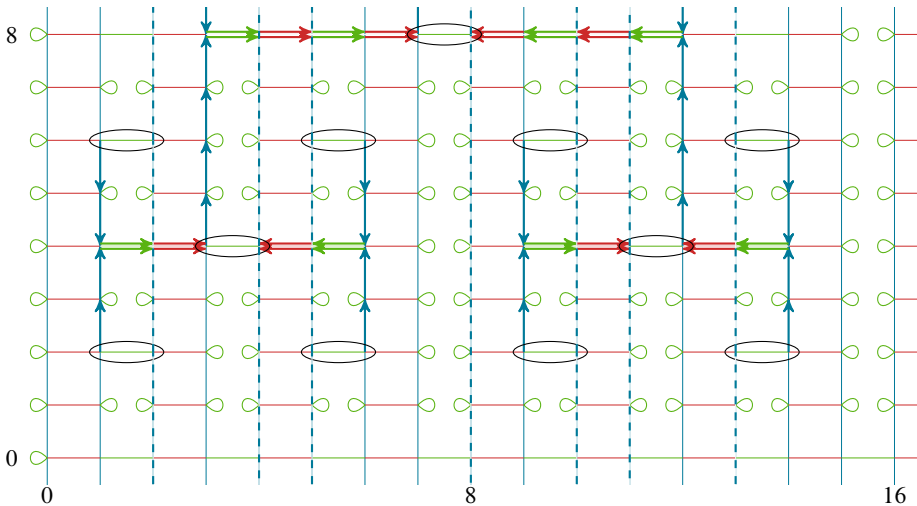

We are ready to put the pieces together:

Proof of Theorem C. Consider the graph with the collection of clusters as vertex set, connected by “real” edges (dashed above) and “imaginary” edges (following arrows). Consider furthermore domino problems on that graph, on which we impose the additional

constraint that, at every 3-cluster, the left incoming double arrow carries the same pair of dominoes as the right incoming double arrow. This is of course the same as considering the domino problem on the quotient graph in which the left and right incoming double arrows are identified, and so are the subgraphs they originate from; thus in the image above columns $0 \dots 2$ and $7 \dots 5$ are identified, columns $0 \dots 6$ and $15 \dots 9$ are identified, etc. The resulting graph is a tiling of the hyperbolic horoball by triangles and squares:

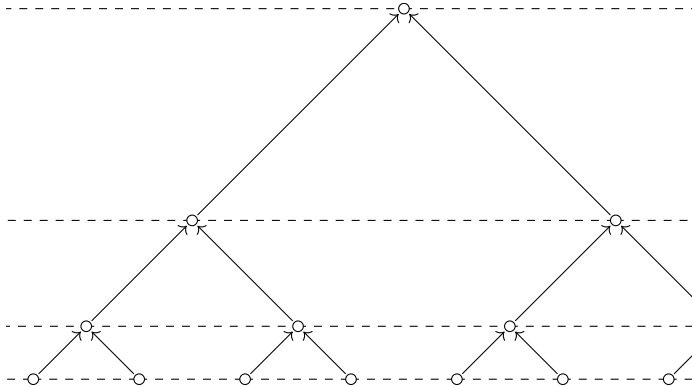

We invoke the classical fact that the domino tiling is undecidable on the hyperbolic plane [12] (see also [15]). These sources typically consider the tiling of the hyperbolic plane by pentagons, but the problems are equivalent, since every pair of triangle and neighbouring square may be converted to a pentagon by ignoring their common edge. ■

6. Barbieri–Sablik’s self-similar structures

In [2], Barbieri and Sablik consider substitutional colourings of the Euclidean space, as means of defining domino problems on self-similar sets. They consider a black/white colouring s of a $k_1 \times \dots \times k_d$ box in \mathbb{Z}^d , for definiteness $\{0, \dots, k_1 - 1\} \times \dots \times \{0, \dots, k_d - 1\}$; they define λ_0 as a black box at the origin, and λ_n for $n \geq 1$ as the colouring of the $k_1^n \times \dots \times k_d^n$ box obtained by replacing, in λ_{n-1} , every black box by s and every white box by an all-white box of size $k_1 \times \dots \times k_d$. Let then Λ_s denote the generated \mathbb{Z}^d -subshift: it consists of all maps $\tau: \mathbb{Z}^d \rightarrow \{\circ, \bullet\}$ such that, for every finite subset $P \subset \mathbb{Z}^d$, the restriction of τ to P coincides, up to translation, with the restriction of some λ_n to some subset $P + x$ contained in the box λ_n .

Barbieri and Sablik then consider the following modification of the domino problem on \mathbb{Z}^d , called “ s -domino problem”: an instance is a set of colours $B = \{\circ\} \sqcup B_\bullet$ and tileset $\Theta \subset B \times \{-1, 0, 1\}^d \times B$, assumed to contain $(\circ, \varepsilon, \circ)$ for all ε ; there is a natural map $\pi: B \rightarrow \{\circ, \bullet\}$ given by $B_\bullet \rightarrow \{\bullet\}$. Then the answer should be “yes” if and only if there exists a non-trivial valid colouring of \mathbb{Z}^d that projects to Λ_s , namely a colouring $\tau: \mathbb{Z}^d \rightarrow B$ with $\pi \circ \tau \in \Lambda_s$ and $\tau \notin \{\circ\}^{\mathbb{Z}^d}$ and $(\tau(x), \varepsilon, \tau(x + \varepsilon)) \in \Theta$ for all $x \in \mathbb{Z}^d$,

$\varepsilon \in \{-1, 0, 1\}^d$. (Their formulation uses more general patterns than dominoes, but this is equivalent by Lemma 2.1.)

Here are three examples of substitutions, all on the plane, taken from their article:

$$\blacksquare \rightarrow \begin{matrix} \square & \blacksquare \\ \blacksquare & \blacksquare \end{matrix} \quad \blacksquare \rightarrow \begin{matrix} \blacksquare & \blacksquare & \blacksquare \\ \blacksquare & \square & \blacksquare \\ \blacksquare & \blacksquare & \blacksquare \end{matrix} \quad \blacksquare \rightarrow \begin{matrix} \blacksquare & \blacksquare & \blacksquare & \blacksquare \\ \blacksquare & \square & \square & \blacksquare \\ \blacksquare & \blacksquare & \square & \blacksquare \\ \blacksquare & \blacksquare & \blacksquare & \blacksquare \end{matrix} \tag{6.1}$$

Iteration of the first rule produces a discrete approximation of the Sierpiński gasket, for which Barbieri and Sablik prove that the domino problem is decidable (as we saw in Section 4.1). The third rule produces a discrete approximation of the Sierpiński carpet, for which they prove that the domino problem is undecidable. They list the second example as an interesting border case between decidability and undecidability.

In terms of shift spaces, an instance of the s -domino problem is a set \mathcal{F} of forbidden patterns on an alphabet $B = \{\circ\} \sqcup B_\bullet$, leading to a natural map $\pi: B^{\mathbb{Z}^d} \rightarrow \{\circ, \bullet\}^{\mathbb{Z}^d}$, and the question is whether there is an \mathcal{F} -avoiding configuration in $\pi^{-1}(\Lambda_s \setminus \{\circ\}^{\mathbb{Z}^d})$, namely if

$$\pi^{-1}(\Lambda_s \setminus \{\circ\}^{\mathbb{Z}^d}) \cap X_{\mathcal{F}} \neq \emptyset.$$

A variety of related questions may be asked, for example “does one have $\pi(X_{\mathcal{F}}) \supseteq \Lambda_s$?” The substitution s induces a self-map \bar{s} of $\{\circ, \bullet\}^{\mathbb{Z}^d}$, replacing each \bullet by the grid s while preserving the origin. Define

$$\Lambda'_s = \bigcap_{n \geq 0} \bar{s}^n(\{\circ, \bullet\}^{\mathbb{Z}^d}),$$

the set of configurations that admit infinitely many preimages under \bar{s} . Then Λ'_s contains Λ_s and possibly some extra “limit” configurations, such as the combination of different elements of Λ_s on different orthants. The above questions “ $\pi(X_{\mathcal{F}}) \subseteq \Lambda'_s$?” and “ $\pi(X_{\mathcal{F}}) \cap \Lambda'_s \neq \{\circ\}^{\mathbb{Z}^d}$?” can also be asked for Λ'_s .

Although in some cases these questions can have different answers, it is possible, at least in all cases I considered, to reduce decidability of one question to the other, so I will not devote too much attention to these distinctions. For example, unless the substitution s is constant, the subshift Λ_s is almost minimal (it has a unique closed invariant subset $\{\circ\}^{\mathbb{Z}^d}$), in which case $\pi(X_{\mathcal{F}}) \cap \Lambda_s$ is either $\{\circ\}^{\mathbb{Z}^d}$ or Λ_s itself.

My point is, rather, that a wealth of interesting tiling problems arises within the language of Schreier graphs, and that domino problems defined via substitutions in Euclidean space can be reformulated in a natural way by ridding them of an ambient space in which they embed. In the case of *contracting* groups, the Schreier graphs can in principle be quasi-isometrically imbedded in \mathbb{R}^d for some d , and therefore could, in principle, be cast into a language of substitutions. This does not even seem approachable for other examples such as the long range graph.

6.1. Self-similar structures

Let us see how graphs naturally arise from the substitution s . Let M denote the diagonal matrix with entries k_1, \dots, k_d along the diagonal. We first associate with s a self-similar

structure in the sense of Kigami. Let S denote the set of coordinates $\in \mathbb{Z}^d$ at which $s(\blacksquare)$ has a black box, and for each $v \in S$ consider the affine map $F_v(x) = M^{-1}(x + v)$. Start by $K_0 = [0, 1]^d$, and for each $n \geq 0$ set $K_{n+1} = \bigcup_{v \in S} F_v(K_n)$. Set finally $K = \bigcap_{n \geq 0} K_n$. Then $(K, \{F_v\}_{v \in S})$ is a self-similar structure: the maps F_v are contractions, so the coding map $\pi: S^{-\mathbb{N}} \rightarrow K$ maps $(v_i)_{i \leq 0}$ to the limit of $F_{v_0}(F_{v_{-1}}(F_{v_{-2}}(\dots)))$.

The recipe of Section 3 then produces graphs Γ_ξ for all $\xi \in S^{\mathbb{N}}$; however we shall need *labelled* graphs for the domino problem, so we rather turn s into a self-similar group.

In fact, the most natural algebraic structure to associate with a substitution s is a *pseudo-group*, namely a collection of partially-defined bijections of $S^{\mathbb{N}}$, closed under composition. These bijections will be given by partially-defined maps $\Phi: A \times S \dashrightarrow S \times A$. I will remark later how to obtain *bona fide* group actions.

The transducer Φ associated with the substitution s has alphabet S and stateset $A = \{-1, 0, 1\}^d$. For each $v \in S, a \in A$: if $v + a = v' + M(a')$ for some $v' \in S, a' \in A$, then $\Phi(a, v) = (v', a')$, and otherwise $\Phi(a, v)$ is not defined. Note that the v', a' above are unique if they exist, since M has full rank and no two elements of S are congruent modulo $M(\mathbb{Z}^d)$. In particular, state 0^d is the identity. For example, the transducer associated with the Sierpiński gasket, with alphabet $\{0 = (0, 0), 1 = (1, 0), 2 = (1, 1)\}$, has the following form:

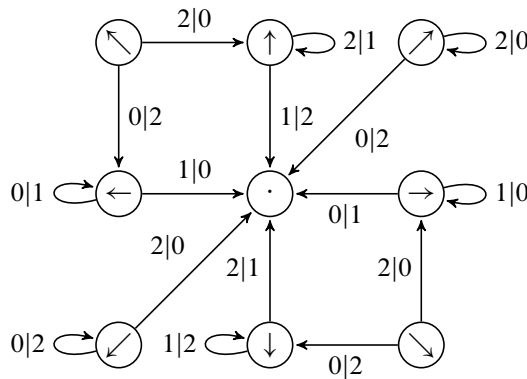

Note that the transducer Φ is contracting, and that its nucleus is a subset of A . However, it need not be recurrent, for example the state \swarrow above is not.

To obtain a genuine, everywhere-defined action, we can now replace every generator a by a product $b \cdot c$ of two involutions, and force b or c to have fixed points where a is not defined. In effect, we replace the orbits of a , which are lines or line segments, by orbits of (finite or infinite) dihedral groups $\langle b, c \rangle$. This adds notational complications without changing much about the Schreier graphs. There is, however, the important effect that we are adding loops to the Schreier graph, which can then be detected by dominoes.

To relate the domino problems on s and the Schreier graphs of Φ , fix a sequence $\xi = (\xi_n) \in S^{\mathbb{N}}$ of distinguished black boxes. There is then a well-defined associated colouring of the plane: start by the partial colouring λ_1 of \mathbb{Z}^d with ξ_1 at the origin; note that it

extends to the partial colouring λ_2 with $\xi_1 \xi_2$ (namely, the box ξ_1 inside the box ξ_2) at the origin; and so on, with box $\xi_1 \dots \xi_n$ of λ_n at the origin. If the limit does not colour all \mathbb{Z}^d , it means that almost all ξ_i lie on some boundary facet of the box s . Extend then the colouring to \mathbb{Z}^d by \circ on all not-yet-coloured vertices.

On the other hand, consider the Schreier graph of the partial action of $\langle A \rangle$ on ξ , and call this graph Γ_ξ . The following is an immediate translation:

Proposition 6.1. *Assume that the collection of black squares in s is connected, and consider $\xi \in S^{\mathbb{N}}$. Then the domino problem “does there exist a colouring $\tau: \mathbb{Z}^d \rightarrow B$ projecting to τ_ξ ?” is equivalent to the domino problem on Γ_ξ .*

Proof. Since the black squares in s are connected, the Schreier graph of the partial action of $\langle A \rangle$ on S^n is connected for all n ; so the orbit $\langle A \rangle \cdot \xi$ is naturally in bijection with the black boxes in τ_ξ .

The edges of Γ_ξ are also naturally in bijection with the edges of the adjacency graph of black boxes in τ_ξ . In considering the domino problem above τ_ξ , there are also edges between white and black boxes: the tile at a black box can “sense” whether its neighbour is white, while the graph Γ_ξ has no such edges. This is however easy to remedy by adding extra layers to the tiling: for example, to detect whether the left neighbour is white, add a colour ℓ with no domino $(*, \rightarrow, \ell)$, and force by local rules the colour ℓ to appear as often as s requires it.

If almost all ξ happen to lie on the same facet of s , then the Schreier graph Γ_ξ is exceptional, and its vertices correspond to only an orthant of \mathbb{Z}^d . The tiling τ_ξ , likewise, was extended by \circ on the complement of the orthant. ■

Even though there is a continuum of different Schreier graphs, varying ξ , there are only finitely many different domino problems: the collection of finite balls in the Γ_ξ only depends on which sides of the box s contain all but finitely many of the ξ_n ’s. It follows that the “substitutional domino problems” of Barbieri–Sablik and the graph domino problems Γ_ξ are essentially equivalent.

6.2. The H -graph

In Section 5.2, we studied in detail the substitution defined by the middle example of (6.1), here called the H -graph because of the shape of its black boxes. Zooming at the central square produces a symmetric figure, and the graph given in Section 1.2 is just half of the picture. The domino problems are equivalent on the graph and its half, and I chose to work with the half-graph because the transducer producing it is simpler.

The recipe producing a transducer from a substitution, outlined above, would have produced a partial action of $\langle \{-1, 0, 1\}^2 \rangle$ on $\{1, \dots, 7\}^{\mathbb{N}}$. Firstly, by simplifying the resulting graph, I could put it more nicely in the plane, and use only 4 symbols instead of 7. One of the generators, the vertical translation $(0, 1)$, can be defined everywhere, and rewritten z ; while the other one, $(1, 0)$, is replaced by two involutions x, y whose orbits

generate dihedral groups of order 2^{s+2} on the row at height $2^s(2n + 1)$, and an infinite dihedral group on the horizontal axis.

It would also have been possible to extend the partial action into a genuine group action, by letting, in the recursive formulas above, $\Phi(a, v) = (v', a^\varepsilon)$ with v' the first black box following v cyclically in direction a ; and $\varepsilon = 1$ if v' is reached by wrapping around and $\varepsilon = 0$ if not. We are then adding edges to the graph Γ_ξ . Applying this recipe to the simplification of the H -graph produces the following transducer:

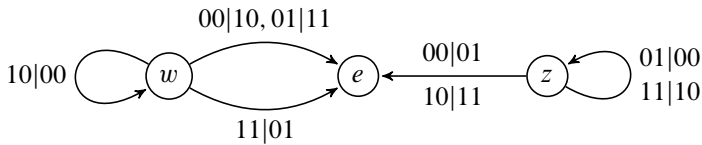

In it, the edge ‘11|01’ from w to e should be removed to define a partial action of w ; the Schreier graph then has vertices naturally in bijection with \mathbb{Z}^2 , via binary encoding, and is made of two copies of the graph given in Section 1.2, joined by an edge. This changes nothing to the fundamental nature of the domino problem.

6.3. Substitutions with unbounded connectivity

In the next-to-last section of [2], Barbieri and Sablik propose a partition of substitutions into different classes, by means of which they conjecturally settle the decidability of the domino problem. Firstly, even if this is not explicit, they assume that the collection S of black squares in s is connected. They distinguish a set $\mathbb{W} \subset \{-1, 0, 1\}^d$ of directions, which correspond to the recurrent states of the transducer Φ above. Assuming that the substitution maps the unit cube to a box of size (k_1, \dots, k_d) , they define then *flexible lines in direction t* as sequences $x_0, x_1, \dots, x_n = x_0 + (0, \dots, k_t, \dots, 0)$ in S with $x_j - x_{j-1} \in \mathbb{W}$ for all $j = 1, \dots, n$; and say s has *bounded connectivity* if there is at most one flexible line in each direction, while s has an *isthmus* if there is one flexible line in one direction, and at least two disjoint flexible lines in another.

Barbieri and Sablik claim that if substitution s has bounded connectivity, then the s -domino problem is decidable; and that this follows from an adaptation of their main theorem. Their definition of bounded connectivity seems a bit too wide for this to hold; for example, the substitution

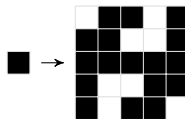

may also simulate the hyperbolic grid, yet follows their definition of “bounded connectivity”. What is true, and follows from their Theorem 1 and our Theorem A, is that if the transducer Φ is bounded, then the associated domino problem is decidable.

Moreover, it could well be that Φ is not bounded, but a *conjugate* of Φ is bounded. Algebraically, this is just a conjugate of the (pseudo)group by a transformation of $S^\mathbb{N}$,

itself given by an initial transducer. This may be phrased in the following manner: a substitution is *conjugate to bounded* if for every direction $t \in \{1, \dots, d\}$ there is a partition of $S \sqcup (S + (0, \dots, k_t, \dots, 0))$ into two pieces $S_0 \sqcup S_1$ such that there is a single edge in direction t connecting S_0 to S_1 . (The case of bounded transducers corresponds to $S_0 = S$ and $S_1 = S + (0, \dots, k_t, \dots, 0)$.)

Proposition 6.2. *If s is conjugate to bounded, then the s -domino problem is decidable.*

Proof. As the name hints, we shall show that the transducer Φ may be conjugated to a bounded transducer. We do this one direction at a time. In direction $a \in A$, let the partition be $S_0 \sqcup S_1$. Define then the initial transducer Ψ , with alphabet S , stateset $\{\psi, a\psi\}$ and initial state ψ , by $\Psi(\psi, v) = (v, a^\varepsilon\psi)$ if $v + a \in S_\varepsilon$. Then the conjugate of Φ by ψ is bounded in direction a . ■

Now, minimality of the dynamical system Λ_s implies that, if s contains an isthmus, then its associated colourings contain densely a (possibly deformed) copy of the H -substitution; or, equivalently, the H -graph. Furthermore, local rules (purely based on what appears inside s) allow this H -graph to be distinguished as a quasi-isometrically imbedded subgraph. From this we deduce:

Proposition 6.3. *If s contains an isthmus, then the s -domino problem is undecidable.* ■

Acknowledgements. I am grateful to Bruno Courcelle and Ville Salo for helpful comments and generous replies to my (sometimes obscure or naive) questions.

References

- [1] G. Amir, O. Angel, and B. Virág, Amenability of linear-activity automaton groups. *J. Eur. Math. Soc. (JEMS)* **15** (2013), no. 3, 705–730 Zbl [1277.37019](#) MR [3085088](#)
- [2] S. Barbieri and M. Sablik, The domino problem for self-similar structures. In *Pursuit of the universal*, pp. 205–214, Lecture Notes in Comput. Sci. 9709, Springer, Cham, 2016 Zbl [1479.05049](#) MR [3535162](#)
- [3] L. Bartholdi and V. Salo, Simulations and the lamplighter group. *Groups Geom. Dyn.* **16** (2022), no. 4, 1461–1514
- [4] I. Benjamini and C. Hoffman, ω -periodic graphs. *Electron. J. Combin.* **12** (2005), Research Paper 46 MR [2176522](#)
- [5] R. Berger, The undecidability of the domino problem. *Mem. Amer. Math. Soc.* **66** (1966) Zbl [0199.30802](#) MR [216954](#)
- [6] I. Bondarenko, Growth of Schreier graphs of automaton groups. *Math. Ann.* **354** (2012), no. 2, 765–785 Zbl [1280.20042](#) MR [2965260](#)
- [7] I. Bondarenko and V. Nekrashevych, Post-critically finite self-similar groups. *Algebra Discrete Math.* (2003), no. 4, 21–32 Zbl [1068.20028](#) MR [2070400](#)
- [8] D. Caucal, On infinite transition graphs having a decidable monadic theory. In *Automata, languages and programming* (Paderborn, 1996), pp. 194–205, Lecture Notes in Comput. Sci. 1099, Springer, Berlin, 1996 Zbl [1045.03509](#) MR [1464449](#)

- [9] D. D'Angeli, A. Donno, M. Matter, and T. Nagnibeda, Schreier graphs of the Basilica group. *J. Mod. Dyn.* **4** (2010), no. 1, 167–205 Zbl [1239.20031](#) MR [2643891](#)
- [10] R. Grigorchuk and Z. Šuník, Asymptotic aspects of Schreier graphs and Hanoi Towers groups. *C. R. Math. Acad. Sci. Paris* **342** (2006), no. 8, 545–550 Zbl [1135.20016](#) MR [2217913](#)
- [11] E. Jeandel, Translation-like actions and aperiodic subshifts on groups. 2015, arXiv:[1508.06419](#)
- [12] J. Kari, The tiling problem revisited (extended abstract). In *Machines, computations, and universality* (Orléans, 2007), pp. 72–79, Lecture Notes in Comput. Sci. 4664, Springer, Berlin, 2007 Zbl [1211.03062](#)
- [13] J. Kari, On the undecidability of the tiling problem. In *Theory and practice of computer science* (Nový Smokovec, 2008), pp. 74–82, Lecture Notes in Comput. Sci. 4910, Springer, Berlin, 2008 Zbl [1133.03020](#)
- [14] J. Kigami, Harmonic calculus on p.c.f. self-similar sets. *Trans. Amer. Math. Soc.* **335** (1993), no. 2, 721–755 Zbl [0773.31009](#) MR [1076617](#)
- [15] M. Margenstern, The domino problem of the hyperbolic plane is undecidable. *Theoret. Comput. Sci.* **407** (2008), no. 1-3, 29–84 Zbl [1152.03036](#) MR [2462998](#)
- [16] A. A. Mučnik, On the unsolvability of the problem of reducibility in the theory of algorithms. *Dokl. Akad. Nauk SSSR (N.S.)* **108** (1956), 194–197 Zbl [0070.24701](#) MR [0081859](#)
- [17] D. E. Muller and P. E. Schupp, The theory of ends, pushdown automata, and second-order logic. *Theoret. Comput. Sci.* **37** (1985), no. 1, 51–75 Zbl [0605.03005](#) MR [796313](#)
- [18] V. Nekrashevych, *Self-similar groups*. Math. Surveys Monogr. 117, American Mathematical Society, Providence, RI, 2005 Zbl [1087.20032](#) MR [2162164](#)
- [19] O. Schreier, Die Untergruppen der freien Gruppen. *Abh. Math. Sem. Univ. Hamburg* **5** (1927), no. 1, 161–183 Zbl [53.0110.01](#) MR [3069472](#)
- [20] L. S. Schulman, Long range percolation in one dimension. *J. Phys. A* **16** (1983), no. 17, L639–L641 MR [723249](#)
- [21] D. Seese, The structure of the models of decidable monadic theories of graphs. *Ann. Pure Appl. Logic* **53** (1991), no. 2, 169–195 Zbl [0733.03026](#) MR [1114848](#)
- [22] S. Sidki, Automorphisms of one-rooted trees: growth, circuit structure, and acyclicity. *J. Math. Sci. (New York)* **100** (2000), no. 1, 1925–1943 Zbl [1069.20504](#) MR [1774362](#)
- [23] H. Wang, Proving theorems by pattern recognition, II, *Bell Syst. Tech. J.* **40** (1961), no. 1, 1–41

Received 9 December 2020.

Laurent Bartholdi

Fachrichtung Mathematik + Informatik, Universität des Saarlandes, 66123 Saarbrücken, Germany;
laurent.bartholdi@gmail.com