



The Poincaré problem for reducible curves

Pedro Fortuny Ayuso and Javier Ribón

Abstract. We provide sharp lower bounds for the multiplicity of a local holomorphic foliation defined in a complex surface in terms of data associated to a germ of invariant curve. Then we apply our methods to invariant curves whose branches are isolated, i.e., they are never contained in non-trivial analytic families of equisingular invariant curves. In this case, we show that the multiplicity of an invariant curve is at most twice the multiplicity of the foliation. Finally, we apply the local methods to foliations in the complex projective plane.

1. Introduction

The Poincaré problem (bounding the degree, or equivalently, the genus of an invariant curve of a foliation in projective space) has been thoroughly studied lately [1, 4, 5, 8, 9, 14, 15] (to cite several relevant instances). We want to obtain lower bounds for the complexity of a foliation in terms of data associated to an invariant curve and as much as possible not on the foliation itself, following an approach that is similar, in spirit, to the point of view of Cerveau and Lins-Neto in [6]. Indeed, one of the main contributions of the paper is that its methods do not depend on the reduction of singularities of the foliation, and moreover, some of its results do not depend on the foliation and depend just on the invariant curve.

In a previous work [3] with J. Cano, we covered the local case for irreducible *branches* (local analytic curves with a single irreducible component). There we defined the concept of *virtual multiplicity* of an analytic branch γ : if n is its multiplicity and $p_1/q_1, \dots, p_g/q_g$ are its characteristic exponents, then $\mu(\gamma)$ is the denominator of the last-but-one characteristic exponent: $\mu(\gamma) = q_{g-1}$. Despite its seemingly artificial nature, it has an intuitive geometric interpretation: let $\tau: (\mathbb{C}^2, 0) \rightarrow (\mathbb{C}^2, 0)$ be the ramification map $\tau(u, y) = (u^n, y)$, and let π_τ be the minimal resolution of singularities of $\tau^{-1}(\gamma)$ (which is a tree, as $\tau^{-1}(\gamma)$ is a union of n non-singular branches). Then $\mu(\gamma)$ is exactly the number of irreducible components of the exceptional divisor $E_\tau = \pi_\tau^{-1}(0, 0)$ which contain no center of the sequence π_τ , or equivalently, components with -1 self-intersection (so to say, *terminal* components).

In the case of a reducible curve Γ , we generalize the virtual multiplicity in two ways. The first one is the obvious one: if $\tau: (\mathbb{C}^2, 0) \rightarrow (\mathbb{C}^2, 0)$ is a ramification map which turns Γ

into a union of smooth branches, and π_τ is the resolution of singularities of $\tau^{-1}(\Gamma)$, then one can define the *terminal virtual multiplicity* $\mu_T(\Gamma)$ as the number of terminal components in $E_\tau = \pi_\tau^{-1}(0, 0)$. However (see Example 3.6), this number might be too low, and one can also consider the set of irreducible components of E_τ meeting one of the branches of the strict transform of $\tau^{-1}(\Gamma)$ by π_τ ; we call this number the *divisorial virtual multiplicity* $\mu_D(\Gamma)$, which is at least equal to $\mu_T(\Gamma)$. If Γ is irreducible, $\mu_D(\Gamma) = \mu_T(\Gamma)$ (and both equal $\mu(\Gamma)$), but in the general case they may differ. We denote by $v_0(\mathcal{F})$ and $v_0(\Gamma)$ the multiplicities at the origin of \mathcal{F} and Γ , respectively. Our first result is the following.

Theorem 1.1. *Let \mathcal{F} be a germ of holomorphic foliation defined in a neighborhood of 0 in \mathbb{C}^2 . Let Γ be a germ of singular invariant curve. Then we have*

$$v_0(\mathcal{F}) \geq \max\left(\mu_T(\Gamma), \frac{\mu_D(\Gamma)}{2}\right).$$

Notice how only the geometric structure of the invariant curve Γ is relevant: there is no hypothesis on \mathcal{F} . We provide examples showing that the bound in Theorem 1.1 is sharp. Moreover, the values of $\mu_T(\Gamma)$ and $\mu_D(\Gamma)$ can be calculated directly from the Puiseux expansions of the irreducible components of Γ .

The irreducible components of $\tau^{-1}(\Gamma)$ can be partitioned in packages, where each package contains those components of $\tau^{-1}(\Gamma)$ whose strict transform intersects the same component of E_τ . If we consider a curve $\Gamma' \subset \tau^{-1}(\Gamma)$ that contains exactly one curve in each package, we obtain $\mu_D(\Gamma) = v_0(\Gamma')$. So we obtain a linear lower bound $v_0(\mathcal{F}) \geq v_0(\Gamma')/2$ for the multiplicity of \mathcal{F} in terms of the multiplicity of a subcurve Γ' of $\tau^{-1}(\Gamma)$. Moreover, since $v_0(\Gamma) = v_0(\tau^{-1}(\Gamma))$, we get $v_0(\mathcal{F}) \geq v_0(\Gamma)/2$ if there is exactly one curve in each package.

Once the most general case is studied, we turn our sight to curves Γ from whose multiplicity $v_0(\Gamma)$ one can compute a non-trivial lower bound of $v_0(\mathcal{F})$. It is here where Γ needs to be related to \mathcal{F} : following ideas by Corral and Fernández-Sánchez in [7], we study the case where all the branches γ of Γ are isolated invariant curves of \mathcal{F} (cf. [2]): separatrices γ which do not belong to a non-constant one-dimensional analytic family of equisingular curves invariant for \mathcal{F} .

To tackle this problem, we introduce the less stringent notion of *weak isolation* for invariant curves (cf. Definition 4.2), which includes both the isolated case treated in [7], and the case where Γ has nodal singularities, treated in [6]. The value of this generalization is that weak isolation is invariant by blow-ups (Proposition 4.4) and it only rules out very specific families of equisingular invariant curves determined by Γ . We obtain an analogue of Theorem 1.1 for the weakly isolated case.

Theorem 1.2. *Let Γ be a singular curve that is invariant by a germ of holomorphic foliation \mathcal{F} defined in a neighborhood of the origin in \mathbb{C}^2 . Assume that Γ is weakly isolated. Then $2v_0(\mathcal{F}) \geq v_0(\Gamma)$.*

In this case, the bound in Theorem 1.1 is improved dramatically, since we do not need to remove any irreducible component of Γ .

Then we move on to addressing the global Poincaré problem. In order to do this, lower bounds for the vanishing number $Z_P(\mathcal{F}, \gamma)$ along a branch γ (equal to the GSV-

index [10] except in the singular case) are required. We prove the following result relating the vanishing number along γ of \mathcal{F} to that of df , where $f = 0$ is a reduced equation of Γ .

Theorem 1.3. *Let \mathcal{F} be a germ of foliation defined in a neighborhood of a point P in a complex surface. Let Γ be a germ of weakly isolated \mathcal{F} -invariant singular curve in a neighborhood of P of reduced equation $f = 0$. Denote by \mathcal{H} the foliation $df = 0$. Consider a branch γ of Γ at P . Then we have $Z_P(\mathcal{F}, \gamma) \geq Z_P(\mathcal{H}, \gamma)/2$.*

Theorem 1.3 is the analogue of Theorem 1.2 for the vanishing number along a germ of invariant curve.

Our results conclude with the following application of the previous ideas to the global Poincaré problem for holomorphic foliations in the complex projective plane $\mathbf{CP}(2)$.

Theorem 1.4. *Let Γ be an algebraic curve that is invariant by a foliation \mathcal{F} of $\mathbf{CP}(2)$. Suppose that all singular points P of Γ satisfy that the germ of Γ at P is weakly isolated. Then $\deg(\Gamma) \leq 2 \deg(\mathcal{F}) + 2$. Moreover, $\deg(\Gamma) \leq 2 \deg(\mathcal{F}) + 1$ holds if Γ is irreducible.*

Thus, improving the results of [7], we prove that the degree of Γ admits a linear bound of slope 2 in terms of the degree of \mathcal{F} .

We are convinced that the bound in Theorem 1.4 is optimal in the slope. It may be possible to decrease the intercept 2 to a lower value, but we have not found any examples.

Finally, one of the most relevant properties of Theorems 1.1, 1.2, 1.3 and 1.4 is that they do not depend at all on the reduction of singularities of \mathcal{F} or on the relation between the desingularization of Γ and the pull-back of \mathcal{F} to it. The only hypothesis relating Γ to \mathcal{F} is that the former is invariant by the latter (and the weak isolation properties in Theorems 1.2, 1.3 and 1.4).

2. Setting

In this section, we introduce the invariants and main formulas that we are going to use in order to obtain lower bounds for the multiplicity of a foliation in terms of an invariant curve.

Definition 2.1. Let $f \in \mathbb{C}\{x, y\} \setminus \{0\}$. We define the multiplicity (or vanishing order) $\nu_0(f)$ of f at $0 \in \mathbb{C}^2$ as the unique $k \in \mathbb{N}$ such that $f \in \mathfrak{m}^k \setminus \mathfrak{m}^{k+1}$, where \mathfrak{m} is the maximal ideal of the local ring $\mathbb{C}\{x, y\}$. We define $\nu_0(0) = \infty$.

Let Γ be a germ of reduced complex analytic curve defined in a neighborhood of 0 in \mathbb{C}^2 . It is given by a reduced equation $f = 0$, where $f \in \mathbb{C}\{x, y\}$. We define the multiplicity $\nu_0(\Gamma)$ of Γ at $0 \in \mathbb{C}^2$ as $\nu_0(\Gamma) = \nu_0(f)$.

Remark 2.2. Let $\Gamma = \gamma^1 \cup \dots \cup \gamma^n$ be the decomposition of Γ in irreducible components. We have $\nu_0(\Gamma) = \nu_0(\gamma^1) + \dots + \nu_0(\gamma^n)$.

Next, we define the multiplicity of a foliation.

Definition 2.3. Let \mathcal{F} be a germ of holomorphic foliation defined in a neighborhood of 0 in \mathbb{C}^2 . Let $X = a(x, y)\partial/\partial_x + b(x, y)\partial/\partial_y$ be a holomorphic vector field inducing the foliation \mathcal{F} and such that $\text{Sing}(X) \subset \{0\}$. We define $\nu_0(\mathcal{F}) = \min(\nu_0(a), \nu_0(b))$.

Hertling’s formula [11] (see equation (2.3) below) relates $\nu_0(\mathcal{F})$ to indices associated to a sequence of blow-ups. The following definitions cover all the necessary concepts to state it.

Definition 2.4. Consider the setting in Definition 2.3. Let γ be a germ of irreducible invariant curve for \mathcal{F} , and consider a Puiseux parametrization α of γ . We define $Z_P(\mathcal{F}, \gamma)$ as the vanishing order of α^*X at the origin.

Definition 2.5. Consider the setting in Definition 2.3. Let γ be an irreducible germ of curve defined of irreducible equation $f = 0$, where $f \in \mathbb{C}\{x, y\}$. We define the tangency order between \mathcal{F} and γ at 0 as

$$\text{tang}_0(\mathcal{F}, \gamma) = \dim_{\mathbb{C}} \frac{\mathbb{C}\{x, y\}}{(f, X(f))}.$$

Remark 2.6. The indices defined in Definitions 2.4 and 2.5 are invariant under change of coordinates, and hence they can be defined at any point of a smooth complex surface.

Remark 2.7. Notice that $Z_0(\mathcal{F}, \gamma) \geq 0$ and $\text{tang}_0(\mathcal{F}, \gamma) \geq 0$. Moreover, $Z_0(\mathcal{F}, \gamma) = 0$ is equivalent to $0 \notin \text{Sing}(\mathcal{F})$. Moreover, $\text{tang}_0(\mathcal{F}, \gamma) = 0$ holds if and only if $0 \notin \text{Sing}(\mathcal{F})$ and X is transverse to γ at 0.

Remark 2.8. The index $Z_0(\mathcal{F}, \gamma)$ coincides with the GSV index (Gómez Mont–Seade–Verjovsky) if γ is smooth [10].

Let (M, P_0) be a germ of complex analytic surface, and let $\pi = \pi_1 \circ \dots \circ \pi_k$ be a sequence of blow-ups, where π_1 is the blow-up of P_0 and, for $1 \leq l \leq k$, π_l is the blow-up of a point P_{l-1} in $(\pi_1 \circ \dots \circ \pi_{l-1})^{-1}(P_0)$. For $1 \leq l \leq k$, we shall denote $\tilde{\pi}_l = \pi_1 \circ \dots \circ \pi_l$ the composition, and $E_l = \tilde{\pi}_l^{-1}(P_0)$, $E = \pi^{-1}(P_0)$ and $D_l = \pi_l^{-1}(P_{l-1})$. Abusing notation, we shall also call D_l the strict transform of D_l by $\tilde{\pi}_{l+1}, \dots, \tilde{\pi}_{k-1}$ and the whole blow-up process π . The following notion is just a matter of brevity: a *trace point* of $D_l \subset E_j$ is a non-singular point of E_j belonging to D_l . A point in E_j which is not a trace point will be called a *corner* (of either E_j or $D_l \subset E_j$).

Given a germ of complex foliation \mathcal{F} in (M, P_0) , and a germ of analytic curve Γ at P_0 , we denote by \mathcal{F}_l and Γ_l , respectively, their strict transforms by $\tilde{\pi}_l$, setting $\mathcal{F}_0 = \mathcal{F}$ and $\Gamma_0 = \Gamma$ for completeness.

Definition 2.9. We denote by $\text{Inv}(E)$ the union of the irreducible components of E that are invariant for the foliation \mathcal{F}_k . An irreducible component of E in $\text{Inv}(E)$ will be called an *invariant component*, whereas one not in $\text{Inv}(E)$ will be called a *dicritical component*.

Definition 2.10. The set of connected components of $\text{Inv}(E)$ will be denoted \mathcal{I} . An element $H \in \mathcal{I}$ will be interpreted (without confusion) as such a connected component, or as a set whose elements are the irreducible components of E contained in H . The set \mathcal{I} is empty if E has no invariant irreducible components.

Definition 2.11. Given an irreducible component D_j of E ($1 \leq j \leq k$), its *weight* $w(D_j)$ is the multiplicity of any germ of analytic branch γ such that its strict transform γ_j is smooth and intersects transversally D_j at a trace point.

Remark 2.12. It is easy to see that if P_j is a trace point of some $D_l \subset E_j$, we have $w(D_{j+1}) = w(D_l)$. On the other hand, if P_j is a corner point belonging to irreducible components D_l and $D_{l'}$ of E_j , we have $w(D_{j+1}) = w(D_l) + w(D_{l'})$.

Definition 2.13. Let D_j be a dicritical component of E . The *non-dicritical valence* of D_j , $v_{\bar{d}}(D_j)$, is the number of invariant components D_l of E such that $D_j \cap D_l \neq \emptyset$.

Definition 2.14. Given an irreducible component $D_j \subset E$, and $P \in D_j$, we define

- $\kappa_P(\mathcal{F}_k, D_j) = \text{tang}_P(\mathcal{F}_k, D_j)$ if $D_j \notin \text{Inv}(E)$. Otherwise,
- $\kappa_P(\mathcal{F}_k, D_j) = Z_P(\mathcal{F}_k, D_j) - 1$ if P is a corner point of E and both irreducible components D_j and D_l of E containing P are invariant, or finally,
- $\kappa_P(\mathcal{F}_k, D_j) = Z_P(\mathcal{F}_k, D_j)$ if D_j is invariant but we are not in the preceding case.

Remark 2.15. The index $\kappa_P(\mathcal{F}_k, D_j)$ is non-negative, and it is zero only when

- P is a regular point of \mathcal{F}_k and the separatrix of \mathcal{F}_k through P is either D_j , or transverse to D_j ,
- or P is a corner point, the germ of E at P is invariant, and $Z_P(\mathcal{F}_k, D_j) = 1$.

Finally, as we shall use this concept frequently, we say, in general, that a germ of foliation at (M, P_0) is *1-dicritical* if the exceptional divisor D_1 is non-invariant.

The initial formulas relating the multiplicity $\nu_{P_0}(\mathcal{F})$ to vanishing or tangency indexes after blow-up are

$$(2.1) \quad \nu_{P_0}(\mathcal{F}) = \sum_{P \in \pi_1^{-1}(P_0)} Z_P(\mathcal{F}_1, D_1) - 1$$

if \mathcal{F} is non-1-dicritical at P_0 , and

$$(2.2) \quad \nu_{P_0}(\mathcal{F}) = \sum_{P \in \pi_1^{-1}(P_0)} \text{tang}_P(\mathcal{F}_1, D_1) + 1$$

otherwise. Equation (2.1) was generalized in [2] by Camacho, Lins Neto and Sad for the case where \mathcal{F}_k is non-dicritical, i.e., D_j is invariant for any $1 \leq j \leq k$. The general formula that holds for every situation was discovered by Hertling [11]:

$$(2.3) \quad \nu_{P_0}(\mathcal{F}) + 1 = \sum_{D_j} \sum_{P \in D_j} w(D_j) \kappa_P(\mathcal{F}_k, D_j) + \sum_{D_j \notin \text{Inv}(E)} w(D_j) (2 - v_{\bar{d}}(D_j)).$$

Remark 2.16. In Hertling’s formula, for any $H \in \mathcal{J}$, we have

$$(2.4) \quad \sum_{D_j \in H} \sum_{P \in D_j} w(D_j) \kappa_P(\mathcal{F}_k, D_j) \geq \min_{D_j \in H} w(D_j)$$

by Proposition 3.7 in [3]. This will be one of the main tools in our approach, since we can detect “hidden” index contributions associated to components H in \mathcal{J} whose intersection with the strict transform of an invariant curve is empty. Moreover, the previous inequality is extremely useful, as we do not need to require that \mathcal{F}_k is a reduction of singularities of \mathcal{F} . It is one of the reasons why we do not need a desingularization of \mathcal{F} in our arguments.

We are also interested in how the vanishing order $Z_{P_0}(\mathcal{F}, \gamma)$ behaves under blow-up when γ is an irreducible germ of invariant curve. Indeed, if $\{P_1\} = \gamma_1 \cap D_1$, we have

$$(2.5) \quad Z_{P_0}(\mathcal{F}, \gamma) = Z_{P_1}(\mathcal{F}_1, \gamma_1) + \nu_{P_0}(\gamma)(\nu_{P_0}(\mathcal{F}) - 1)$$

if \mathcal{F} is non-1-dicritical at P_0 , and

$$(2.6) \quad Z_{P_0}(\mathcal{F}, \gamma) = Z_{P_1}(\mathcal{F}_1, \gamma_1) + \nu_{P_0}(\gamma)\nu_{P_0}(\mathcal{F})$$

otherwise (cf. Proposition 14.26 in [12]).

3. Bounds “up to the last Puiseux exponent”

Let Γ be a (possibly reduced) germ of irreducible analytic curve, invariant by a germ of holomorphic foliation \mathcal{F} defined in a neighborhood of the origin of \mathbb{C}^2 . We want to obtain a lower bound for the multiplicity of \mathcal{F} in terms of data associated to Γ , without imposing any additional condition on \mathcal{F} , generalizing the results proved for the irreducible case in [3]. In this section, we find a lower bound obtained by, roughly speaking, discarding the contribution to the multiplicity of the curve Γ provided by the last Puiseux characteristic exponents of its irreducible branches.

Let us fix the notation for this section. We assume that both \mathcal{F} and Γ are singular at $(0, 0) \in \mathbb{C}^2$ (i.e., Γ has multiplicity at least 2 and \mathcal{F} at least 1). If $g \geq 1$ is the genus of Γ (i.e., the number of Puiseux characteristics) and $p_1/q_1, \dots, p_g/q_g$ are the Puiseux characteristic exponents, we defined in [3] the virtual multiplicity $\mu(\Gamma)$ as q_{g-1} . Moreover, we proved that

$$(3.1) \quad \nu_0(\mathcal{F}) \geq \mu(\Gamma),$$

and showed that the inequality is sharp. As a consequence, in order to obtain a sharp lower bound of $\nu_0(\mathcal{F})$ in terms of Γ , we need to discard the “contribution of the last Puiseux exponent”.

In the general case, decompose Γ into its irreducible components $\Gamma = \gamma^1 \cup \dots \cup \gamma^q$. If \mathcal{F} is not 1-dicritical, then up to a linear change of coordinates we may assume that $x = 0$ is not one of the lines of the tangent cone of \mathcal{F} . If, on the contrary, \mathcal{F} is 1-dicritical, we may assume (after an analytic change of coordinates) that $x = 0$ is not the tangent cone of any γ^j for $1 \leq j \leq q$, that $x = 0$ is \mathcal{F} -invariant, and that the point defined by $x = 0$ in $\pi_1^{-1}(0, 0)$ is a regular point of \mathcal{F}_1 .

For each of $\gamma^1, \dots, \gamma^q$, let n_1, \dots, n_q be its corresponding multiplicity. We denote $n = \text{lcm}(n_1, \dots, n_q)$ and $\tau(x, y) = (x^n, y)$.

Remark 3.1. From the hypothesis on \mathcal{F} and Γ follows that $\nu_0(\tau^*\mathcal{F}) = \nu_0(\mathcal{F})$ and $\nu_0(\tau^{-1}(\Gamma)) = \nu_0(\Gamma)$.

Our choice of τ implies that all the irreducible components of $\tau^{-1}(\Gamma)$ are smooth, and that there are exactly $\nu_0(\Gamma)$ of them. We are going to desingularize the curve $\tau^{-1}(\Gamma)$. In parallel to the notation of the previous section, we let $\pi_\tau = \pi_1^\tau \circ \dots \circ \pi_r^\tau$ be the sequence of blow-ups in the minimal desingularization of $\tau^{-1}(\Gamma)$, we denote $\tilde{\pi}_l^\tau = \pi_1^\tau \circ \dots \circ \pi_l^\tau$, E_τ the exceptional divisor of π_τ , and $D_{\tau,l}$ the irreducible component of E_τ corresponding to $\tilde{\pi}_l^\tau$, that is, $D_{\tau,l} = (\pi_l^\tau)^{-1}(P_{l-1})$.

Definition 3.2. An irreducible component $D \subset E_\tau$ is *terminal* if D is not the father of any other divisor: assuming D is the exceptional divisor of π_l^τ , then no point of D is a center for the blow-ups $\pi_{l+1}^\tau, \dots, \pi_k^\tau$. Equivalently, D has -1 self-intersection as a submanifold of $\pi_\tau^{-1}(\mathbb{C}^2)$. We denote by \mathcal{J}_τ the set of connected components of $\text{Inv}(E_\tau)$.

We say that a component $H \in \mathcal{J}_\tau$ is terminal if it contains a terminal irreducible component of E_τ .

Remark 3.3. Since Γ has multiplicity at least 2, given any terminal component D of E_τ , at least two irreducible components of $\tau^{-1}(\Gamma)$ have strict transforms that intersect D .

Definition 3.4. With the same notations as above, we define the *terminal virtual multiplicity* $\mu_T(\Gamma)$ of Γ as the number of terminal irreducible components of E_τ . We define the *divisorial virtual multiplicity* $\mu_D(\Gamma)$ as the number of irreducible components of E_τ meeting the strict transform of $\tau^{-1}(\Gamma)$.

Remark 3.5. The numbers $\mu_T(\Gamma)$ and $\mu_D(\Gamma)$ can be computed from the Puiseux expansions of $\gamma^1, \dots, \gamma^q$. Let the curve γ^j have a Puiseux expansion $(t^{n_j}, c_j(t))$. Any power series of the form

$$(t, c_j(e^{2\pi il/n_j} t^{1/n_j}))$$

is also a parametrization of the same curve for $0 \leq l < n_j$. The expression

$$(t, c_j(e^{2\pi il/n_j} t^{n/n_j}))$$

provides all the parametrizations of the n_j curves in $\tau^{-1}(\gamma^j)$ by taking $0 \leq l < n_j$ (recall that $n = \text{lcm}(n_1, \dots, n_q)$). Let \mathfrak{C}_j be the set consisting of the power series expansions $c_j(e^{2\pi il/n_j} t^{n/n_j})$, where $0 \leq l < n_j$ and $\mathfrak{C} = \bigcup_{j=1}^q \mathfrak{C}_j$. The cardinal of \mathfrak{C} is equal to $\nu_0(\Gamma)$. Consider the natural map $j_l: \mathfrak{C} \rightarrow J^l$ from \mathfrak{C} to the set J^l of l -jets of formal power series for $l \in \mathbb{N}$. Given an l -jet $\sigma \in J^l$, we say that σ is terminal if $j_l^{-1}(\sigma)$ contains at least two elements and $(j_{l+1})_{|j_l^{-1}(\sigma)}$ is injective. We say that σ is divisorial if $j_l^{-1}(\sigma)$ contains at least two elements and there exists σ' in $j_{l+1}(j_l^{-1}(\sigma))$ such that $\#(j_{l+1})_{|j_l^{-1}(\sigma)}^{-1}(\sigma') = 1$. The terminal (respectively, divisorial) virtual multiplicity $\mu_T(\Gamma)$ (respectively, $\mu_D(\Gamma)$) coincides with the number of terminal (respectively, divisorial) jets.

Given $1 \leq j \leq q$, there exists $l \in \mathbb{N} \cup \{0\}$ such that all the fibers of $j_l: \mathfrak{C}_j \rightarrow J^l$ have $\nu_0(\gamma^j)/\mu(\gamma^j)$ elements but $j_{l+1}: \mathfrak{C}_j \rightarrow J^{l+1}$ is injective. As a consequence, $\mu_T(\Gamma)$, $\mu_D(\Gamma)$ and the definition of the virtual multiplicity $\mu(\Gamma)$ in terms of Puiseux characteristic exponents coincide for an irreducible curve Γ . Moreover, we obtain

$$\mu_D(\Gamma) \geq \mu_T(\Gamma) \geq \max(\mu(\gamma^1), \dots, \mu(\gamma^q)).$$

We can interpret $\mu_T(\Gamma)$ and $\mu_D(\Gamma)$ as generalizations of the virtual multiplicity to the reducible case.

Example 3.6. Consider the union $\Gamma = \gamma_1 \cup \gamma_2 \cup \gamma_3 \cup \gamma_4$, where each γ_i corresponds to the arrows in the dual graph given in Figure 1. For instance, $\gamma_1 = (t^3, t^4)$, $\gamma_2 = (t^6, t^8 + t^{10} + t^{11})$, $\gamma_3 = (t^6, t^8 + t^{10} + t^{11} + t^{13})$, and $\gamma_4 = (t^6, t^8 + t^{10} + t^{11} - t^{13})$.

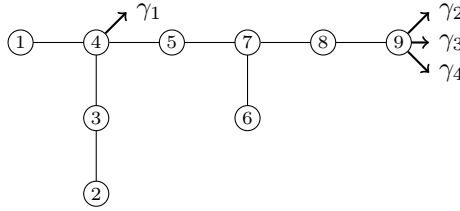

Figure 1. The curve Γ of Example 3.6 is the union of the branches given by the γ_i in the diagram.

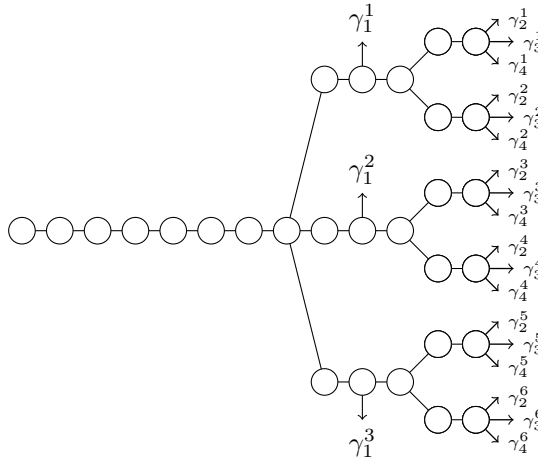

Figure 2. Dual graph of the desingularization of $\tau^{-1}(\Gamma)$, for Γ as in Figure 1. No blow-up center is a corner.

The map τ is $\tau(u, y) = (u^6, y)$, and the dual graph of the desingularization of $\tau^{-1}(\Gamma)$ is schematically shown in Figure 2 (all the centers P_j are trace points). There are 6 terminal irreducible components of E_τ , and 9 components meeting the strict transform of $\tau^{-1}(\Gamma)$, so that $\mu_T(\Gamma) = 6$ and $\mu_D(\Gamma) = 9$.

The next result provides lower bounds for $\nu_0(\mathcal{F})$ in terms of Γ and its desingularization. It implies Theorem 1.1.

Proposition 3.7. *Let \mathcal{F} be a germ of holomorphic foliation defined in a neighborhood of 0 in \mathbb{C}^2 . Let Γ be a germ of singular invariant curve. Given $H \in \mathcal{I}_\tau$, let c_H be the number of irreducible components of $\tau^{-1}(\Gamma)$ whose strict transform meets H . We have*

$$\nu_0(\mathcal{F}) \geq N + \sum_{H \in \mathcal{I}} (\max(c_H, 1) - 1) \geq \max\left(\mu_T(\Gamma), \frac{\mu_D(\Gamma)}{2}\right),$$

where N is the number of dicritical irreducible components of E_τ .

Notice how the first inequality depends on \mathcal{F} , whereas the second is completely independent of it, and requires only geometric information on Γ .

Proof. Let $\mathcal{G}_0 = \tau^* \mathcal{F}$, which satisfies $v_0(\mathcal{G}_0) = v_0(\mathcal{F})$, and $\mathcal{G}_l = (\pi_l^\tau)^*(\mathcal{G}_0)$ for $1 \leq l \leq r$. Notice that $w(D) = 1$ for any irreducible component $D \subset E_\tau$, as π_l^τ is never the blow-up of a corner point. Hertling’s formula [11] in this case becomes

$$v_0(\mathcal{G}_0) = \sum_{D_{\tau,j} \subset E_\tau} \sum_{P \in D_{\tau,j}} \kappa_P(\mathcal{G}_k, D_{\tau,j}) + \sum_{D_{\tau,j} \not\subset \text{Inv}(E_\tau)} (2 - v_{\bar{d}}(D_{\tau,j})) - 1.$$

Given $H \in \mathcal{J}_\tau$, the following two inequalities hold:

$$\sum_{\substack{D \in H \\ P \in D}} \kappa_P(\mathcal{G}_k, D) \geq c_H \quad \text{and} \quad \sum_{\substack{D \in H \\ P \in D}} \kappa_P(\mathcal{G}_k, D) \geq 1.$$

The first one is satisfied because every strict transform of an irreducible component of $\tau^{-1}(\Gamma)$ intersects H at a singular point of \mathcal{G}_k . The second one is a consequence of Proposition 3.7 in [3] (see also Remark 2.16). We deduce

$$v_0(\mathcal{F}) = v_0(\mathcal{G}_0) \geq \sum_{D_{\tau,j} \not\subset \text{Inv}(E_\tau)} (2 - v_{\bar{d}}(D_{\tau,j})) - 1 + \#\mathcal{J}_\tau + \sum_{H \in \mathcal{J}_\tau} (\max(c_H, 1) - 1).$$

Let $D_{\tau,j} \not\subset \text{Inv}(E_\tau)$ be a dicritical irreducible component of E_τ , and let $H_{j,1}, \dots, H_{j,p}$ be the elements of \mathcal{J}_τ intersecting $D_{\tau,j}$ which appear after blowing-up a center in $D_{\tau,j}$ (technically, if $D_{\tau,l} \subset H_{j,r}$, then $l > j$). By definition, $v_{\bar{d}}(D_{\tau,j})$ is at most $p + 1$, except for $j = 1$, where $v_{\bar{d}}(D_{\tau,1}) \leq p$. As a consequence, if N is the number of non-invariant irreducible components of E_τ , we have

$$\sum_{D_{\tau,j} \not\subset \text{Inv}(E_\tau)} (2 - v_{\bar{d}}(D_{\tau,j})) - 1 + \#\mathcal{J}_\tau \geq N,$$

so that

$$(3.2) \quad v_0(\mathcal{F}) = v_0(\mathcal{G}_0) \geq N + \sum_{H \in \mathcal{J}_\tau} (\max(c_H, 1) - 1),$$

which is the first inequality of the statement.

In order to prove the second inequality, given $H \in \mathcal{J}_\tau$, let t_H be the number of terminal components in H . If $t_H \geq 1$, then $c_H \geq 2t_H$, because every terminal component meets at least two branches of the strict transform of $\tau^{-1}(\Gamma)$ (Remark 3.3); hence $c_H - 1 \geq 2t_H - 1 \geq t_H$. This implies that

$$N + \sum_{H \in \mathcal{J}_\tau} (\max(c_H, 1) - 1) \geq \mu_T(\Gamma).$$

We now compare $v_0(\mathcal{F})$ and $\mu_D(\Gamma)/2$. Denote by \mathcal{T}_τ the set of terminal elements of \mathcal{J}_τ . Given $H \in \mathcal{J}_\tau$, we denote by d_H the number of irreducible components of H meeting the strict transform of $\tau^{-1}(\Gamma)$. The inequality $c_H \geq d_H$ always holds. Moreover, $c_H - 1 \geq d_H$ is satisfied for any $H \in \mathcal{T}_\tau$ by Remark 3.3. We have

$$2v_0(\mathcal{F}) \geq 2N + 2 \sum_{H \in \mathcal{J}_\tau} (\max(c_H, 1) - 1) = \star$$

which, expanding all the terms and using the relations between c_H and d_H above, gives

$$\star \geq N + 2 \sum_{H \in \mathcal{T}_\tau} d_H + \sum_{\substack{H \in \mathcal{J}_\tau \setminus \mathcal{T}_\tau \\ c_H \geq 1}} d_H + (N - M) + \sum_{\substack{H \in \mathcal{J}_\tau \setminus \mathcal{T}_\tau \\ c_H \geq 1}} d_H - M,$$

where $M = \#\{H \in \mathcal{J}_\tau \setminus \mathcal{T}_\tau : c_H \geq 1\}$. Any non-terminal $H \in \mathcal{J}_\tau$ has a non-invariant irreducible component of E_τ as one of its adjacent successors, i.e., there exists a non-invariant irreducible component of E_τ that was the result of a blow-up with center in a point in H . Therefore $M \leq N$ holds, and we obtain

$$2\nu_0(\mathcal{F}) \geq N + 2 \sum_{H \in \mathcal{T}_\tau} d_H + \sum_{\substack{H \in \mathcal{J}_\tau \setminus \mathcal{T}_\tau \\ c_H \geq 1}} d_H \geq \mu_D(\Gamma) + \sum_{H \in \mathcal{T}_\tau} d_H \geq \mu_D(\Gamma),$$

as desired. Notice that if $\mathcal{J}_\tau = \emptyset$, the result is straightforward. ■

Remark 3.8. Theorem 1.1 is the analogue in the reducible case of Theorem 3.1 in [3] (where $\mu_T(\Gamma) = \mu_D(\Gamma) = \mu(\Gamma)$).

Remark 3.9. The inequality $\nu_0(\mathcal{F}) \geq \mu(\Gamma)$ is sharp if Γ is a germ of irreducible invariant curve [3], Remark 3.11. By considering a ramification, we obtain examples of reducible invariant curves Γ whose branches are smooth and such that $\nu_0(\mathcal{F}) = \mu_T(\Gamma)$.

Remark 3.10. Consider a reducible curve Γ consisting of n smooth curves $\gamma^1, \dots, \gamma^n$ with $n \geq 2$. Assume that the exceptional divisor E of the desingularization of Γ has $n - 1$ irreducible components D_1, \dots, D_{n-1} , and that only the last one is terminal. This is for instance the situation if $\gamma^j = \{y = x^j\}$ for $1 \leq j \leq n$. Suppose that

- D_j is invariant if and only if j is odd;
- Let $P \in E$. Then $\kappa_P(\mathcal{F}_{n-1}, \Gamma_{n-1}) = 1$ if (E, P) is invariant and $P \in \Gamma_{n-1}$ and $\kappa_P(\mathcal{F}_{n-1}, \Gamma_{n-1}) = 0$ otherwise.

Such an example of foliation \mathcal{F} can be built by using the realization theorem of Lins Neto [13]. The self-intersection of D_j is -2 if $j < n - 1$, and -1 if $j = n - 1$. The foliation is regular and transverse to every even divisor D_j in any point. The odd divisors D_j with $j < n - 1$ have a unique (nondegenerate irreducible) singular point. The divisor D_{n-1} (if $n - 1$ is odd) has two (nondegenerate irreducible) singular points. Such configurations are easy to build. Once \mathcal{F} is fixed, we choose the unique curve through every singular point in $\text{Inv}(E)$, and for any non-invariant irreducible component D_j of E , we choose an invariant curve through a trace point of D_j (or two trace points if $j = n - 1$). In this way, we obtain a foliation \mathcal{F} that leaves invariant a curve Γ with the properties described above. In this case, it is easy to see that $\mu_T(\Gamma) = 1$, $\mu_D(\Gamma) = n - 1$ and

$$\nu_0(\mathcal{F}) = N + \sum_{H \in \mathcal{J}} (\max(c_H, 1) - 1) = \left\lceil \frac{n-1}{2} \right\rceil = \left\lceil \frac{\mu_D(\Gamma)}{2} \right\rceil,$$

cf. equation (3.2), where $\lceil s \rceil$ is the smallest integer greater or equal than s . In particular, Theorem 1.1 is both interesting (since it provides non-trivial lower bounds for $\nu_0(\mathcal{F})$) and sharp.

4. Isolated invariant curves

In the previous section, we bounded from below the multiplicity of a singular foliation \mathcal{F} in terms of invariants of a singular curve Γ consisting of leaves of \mathcal{F} . These invariants depend only on the desingularization of Γ ; in order to obtain a lower bound in terms of the multiplicity of Γ , we need to require Γ to be composed of invariant branches that are isolated somehow: one can get the multiplicity of Γ arbitrary large choosing branches which meet a dicritical component of the exceptional divisor transversely. The first definition in that direction is “not belonging to a dicritical family” (see [7]).

Definition 4.1. Let γ be an irreducible \mathcal{F} -invariant curve. It is called *isolated* if there is no birational morphism $\pi: (M, D) \rightarrow (\mathbb{C}^2, 0)$ such that the strict transform of γ intersects D transversally at a non-corner regular point of the lifted foliation $\pi^*\mathcal{F}$. We say that a reduced invariant curve Γ is isolated if all its irreducible components are isolated.

However, this notion is too restrictive. We shall see that one only needs to rule out specific dicritical families related to Γ and, what is more: some non-isolated irreducible components may be acceptable.

Recall that a *normal-crossings divisor at a point P* is the union of zero, one or two non-singular irreducible curves containing P , and in the last case, they are mutually transverse. Let $\hat{\Gamma}$ be a singular curve invariant for \mathcal{F} , and let $\pi: M \rightarrow (\mathbb{C}^2, 0)$ be its minimal desingularization with $E = \pi^{-1}(0)$. Given an irreducible component γ of $\hat{\Gamma}$, let P_γ the point at which the strict transform of γ meets E , and D_γ the irreducible component of E to which P_γ belongs.

Definition 4.2. We say that a singular curve $\hat{\Gamma}$ is *weakly isolated* for \mathcal{F} if there is a normal-crossings divisor $\bar{\Gamma}$ such that $\hat{\Gamma} = \Gamma \cup \bar{\Gamma}$, and $\Gamma \cap \bar{\Gamma} \subset \{0\}$, with

- $\kappa_{P_\gamma}(\pi^*\mathcal{F}, D_\gamma) \geq 1$ for any irreducible component γ of Γ .

Any irreducible component η of $\hat{\Gamma}$ with $\kappa_{P_\eta}(\pi^*\mathcal{F}, D_\eta) = 0$ will be called *null*, the other components of $\hat{\Gamma}$ will be called *non-null*. Null components are, by definition, included in $\bar{\Gamma}$.

Thus, a weakly isolated curve is composed of an “important” part Γ and a “discardable” one, $\bar{\Gamma}$. Later on, the roles of these two parts will become clear. See Figure 3 for an example.

Remark 4.3. A singular isolated integral curve is weakly isolated (cf. Remark 2.7).

Weak isolation is a powerful concept since it is invariant by blow-ups.

Proposition 4.4. Let $\hat{\Gamma}$ be weakly isolated for \mathcal{F} and let π_1 be the blow-up of the origin. Let $P \in \pi_1^{-1}(0)$ and let $\hat{\Gamma}_P$ be the union of the invariant irreducible components of $\pi^{-1}(\Gamma)$ (the total transform) containing P . Then $\hat{\Gamma}_P$ is a weakly isolated curve for $\pi_1^*\mathcal{F}$ if $\hat{\Gamma}_P$ is singular.

Proof. Write $\hat{\Gamma} = \Gamma \cup \bar{\Gamma}$, where $\bar{\Gamma}$ is the normal-crossings divisor formed by the null components of $\hat{\Gamma}$, and let $\hat{\pi} = \pi_1 \circ \pi'$ be a minimal desingularization of $\hat{\Gamma}$. Notice that $\bar{\Gamma}$ may perfectly be empty. Denote by $\bar{\Gamma}_P$ the strict transform of $\bar{\Gamma}$ at P , and let a be the

number of irreducible components of $\bar{\Gamma}_P$. As $\bar{\Gamma}$ has normal crossings, $a \leq 1$, and if $a = 1$, then $\bar{\Gamma}_P$ is transverse to $D_1 = \pi_1^{-1}(0, 0)$. Let π_P be the minimal desingularization of $\hat{\Gamma}_P$. By definition, π_P (as a sequence of point blow-ups) is contained in the sequence of point blow-ups corresponding to π' . We consider two cases, depending on the invariance of D_1 by \mathcal{F}_1 .

Case D_1 invariant. The desingularization provided by π' of $\hat{\Gamma}_P$ and π_P coincide because $D_1 \subset \hat{\Gamma}_P$. Thus, the null irreducible components of $\hat{\Gamma}_P$ are $\bar{\Gamma}_P$ (if $a \geq 1$) and maybe D_1 by hypothesis. Therefore, $\hat{\Gamma}_P$ is weakly isolated.

Case D_1 non-invariant. The only blow-ups in π' not belonging to π_P must be of points in the successive strict transforms of D_1 . Thus, if non-empty, this sequence corresponds to a single smooth irreducible component γ' of $\hat{\Gamma}_P$ tangent to D_1 , and this curve might be null for $\pi_1^*\mathcal{F}$ (as it is already smooth at P).

Anyway, $\hat{\Gamma}_P$ is indeed weakly isolated for $\pi_1^*\mathcal{F}$, as the only possible null components are γ' and $\bar{\Gamma}_P$, which are transverse. ■

Example 4.5. Consider a foliation having the curves $\bar{\Gamma} \equiv (y = 0)$ and $\Gamma \equiv (y^2 - x^3 = 0)$ as separatrices, and such that if π is the desingularization of $\hat{\Gamma} := \Gamma \cup \bar{\Gamma}$, then D_1 and D_2 are non-invariant, $\bar{\Gamma} \cap D_2$ is non-singular for \mathcal{F}_2 , and D_3 is invariant (see Figure 3). The curve $\hat{\Gamma}$ is weakly isolated but not isolated. Moreover, the strict transform of $\hat{\Gamma}$ by π_1 is also weakly isolated.

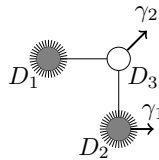

Figure 3. See Example 4.5. If \mathcal{F}_3 is reduced and γ_1, γ_2 are invariant, then $\Gamma = \gamma_1 \cup \gamma_2$ is weakly isolated but not isolated. Its strict transform $\pi_1^*(\Gamma)$ is weakly isolated but not isolated.

In this section, $\hat{\Gamma} = \gamma^1 \cup \dots \cup \gamma^q$ will be a weakly isolated curve for \mathcal{F} , and $\pi = \pi_1 \circ \dots \circ \pi_k$ will denote its minimal desingularization, the rest of the notation being as in Section 2. Recall that $\hat{\Gamma}_k$ meets E_k transversely. We remark again that we only need to study the desingularization of $\hat{\Gamma}$, and not of \mathcal{F} . The only hypothesis on \mathcal{F} is that $\hat{\Gamma}$ is weakly isolated.

We do not follow the ramification approach of Section 3, as the isolation property for a curve Γ is not invariant under ramification even if the ramification locus is different from Γ . Moreover, our approach to the study of the global Poincaré problem through local methods requires calculating vanishing orders of foliations along invariant branches γ of an invariant curve Γ . Later on, we shall use an iterative formula (equation (5.2)) to calculate these vanishing orders. Since the formula collects data associated to a desingularization of Γ , it is convenient to avoid ramifications.

Our approach to providing lower bounds for the multiplicity of a foliation \mathcal{F} in terms of the multiplicity of a weakly isolated curve consists in dividing E_k into connected unions of irreducible components: each starting with the exceptional divisor corresponding to the blow-up of a trace point of a non-invariant component. In order to carry out this division, we require some nomenclature.

Definition 4.6. Let $0 \leq l$ and $l' \leq k - 1$ be indices of two centers of π . We say that $P_{l'}$ is a descendant of P_l (and P_l is an ancestor of $P_{l'}$) if $\pi_{l+1} \circ \dots \circ \pi_{l'}(P_{l'}) = P_l$ or $l = l'$.

For simplicity in later arguments, we consider any point P_l both an ancestor and a descendant of itself.

In Hertling’s formula (2.3),

$$v_{P_0}(\mathcal{F}) + 1 = \sum_{D_j \subset E_k} \sum_{P \in D_j} w(D_j) \kappa_P(\mathcal{F}_k, D_j) + \sum_{D_j \not\subset \text{Inv}(E_k)} w(D_j) (2 - v_{\bar{d}}(D_j)),$$

the *problematic* terms are the ones in the last summation, which correspond to non-invariant components of the exceptional divisor. These points can be of two different kinds: either they arise for the first time from trace points, or they do from corners. The former are the key ones to divide E_k (and, as a consequence, Hertling’s formula) into *controllable* parts. Properly speaking: given $l \in \{0, \dots, k\}$, we shall denote by $D(P_l)$ the set of irreducible components of E_l containing P_l . We say that P_l is a *separating center* (s.c. for brevity) if either $l = 0$ (whence $D(P_0) = \emptyset$) or if $D(P_l)$ is a singleton and its unique element is non-invariant for \mathcal{F}_l . Using this notion, we can divide the exceptional divisor E_k into connected sets each starting “immediately after” a separating center, as in Figure 4, using the following definition:

Definition 4.7. Let $0 \leq l \leq k - 1$ be an index such that P_l is a separating center. We shall denote by \mathcal{D}_l the set of divisors $D_{l'+1}$, with $l' \geq l$, such that $P_{l'}$ is a descendant of P_l and P_l is the unique separating center among the $P_{l'}$ that are both descendants of P_l and ancestors of $P_{l'}$. This gives a partition of $\{0, \dots, k - 1\}$ (or, equivalently, a subdivision of E_k into connected unions of irreducible components):

$$E_k = \bigcup_{P_l \text{ s.c.}} \mathcal{D}_l.$$

See Figure 4 for an example.

The point P_0 is always a separating center by convention, so that \mathcal{D}_0 always contains D_1 at least. Each set \mathcal{D}_l is, essentially, a *controllable* part of E_k in Hertling’s formula, as the next lemmas show.

From now on, $\hat{\Gamma}$ will denote a weakly isolated curve for \mathcal{F} such that $\hat{\Gamma} = \Gamma \cup \bar{\Gamma}$, where $\bar{\Gamma}$ is the union of the null components of $\hat{\Gamma}$. Given a separating center P_l , the curves $\gamma^{l,1}, \dots, \gamma^{l,m_l}$ are the irreducible components of Γ whose strict transforms $\gamma_k^{l,j}$ satisfy $\gamma_k^{l,j} \cap \mathcal{D}_l \neq \emptyset$, and $\bar{\gamma}^{l,1}, \dots, \bar{\gamma}^{l,m_l}$ are the irreducible components of $\bar{\Gamma}$ with $\bar{\gamma}_k^{l,j} \cap \mathcal{D}_l \neq \emptyset$.

If P_l is a separating center, the component \mathcal{D}_l satisfies $\mathcal{D}_l \cap D(P_l) \neq \emptyset$ and $\pi_k \circ \dots \circ \pi_{l+1}(\mathcal{D}_l) = P_l$, and such properties characterize \mathcal{D}_l . In Hertling’s formula (2.3), the sum corresponding to non-invariant components,

$$(4.1) \quad \sum_{D_j \not\subset \text{Inv}(E_k)} w(D_j) (2 - v_{\bar{d}}(D_j)),$$

is now best divided according to the following conditions:

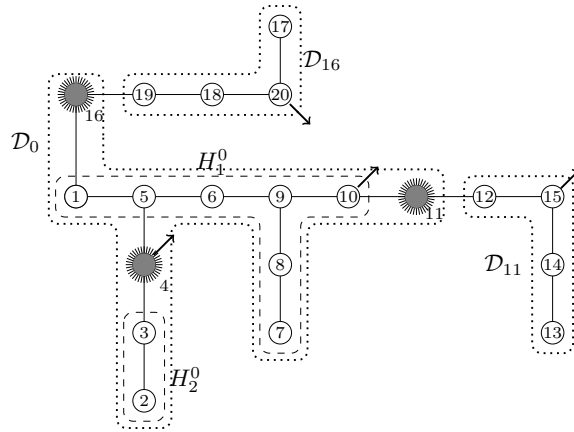

Figure 4. Separating centers and the components \mathcal{D}_l . Each component of the exceptional divisor E_k is numbered according to its order of apparition. Arrows indicate irreducible components of $\tilde{\Gamma}$. Notice how $\mathcal{D}_0 \supset H_1^0 \cup H_2^0$ contains two connected components of \mathcal{I} and three non-invariant irreducible components of E_k .

- (1) For each separating center l with $l > 0$, there is a single irreducible component $\overline{D}(P_l) \in \mathcal{D}_l$ with $\overline{D}(P_l) \cap D(P_l) \neq \emptyset$.
- (2) By convention, we set $\overline{D}(P_0) = \emptyset$ and $w(D(P_0)) = 1$.
- (3) And finally, all the other intersections between a non-invariant component D_j and another component of E arise, by definition, with components of the form \mathcal{D}_r , where P_r is an ancestor of P_{j-1} . There are at most two such components.

Using these three properties, recalling the definition of *non-dicritical* valence $v_{\overline{d}}(D_j)$ (Definition 2.13), for each separating center P_l , we set $\delta(P_l) = 1$ if either $l = 0$ or $\overline{D}(P_l)$ is invariant, and $\delta(P_l) = 0$ otherwise. Define, for any non-invariant D_j (for the sake of simplicity, and where an empty summation is 0),

$$v_{\overline{d}}^a(D_j) = v_{\overline{d}}(D_j) - \sum_{\substack{P \in D_j \\ P \text{ s.c.}}} \delta(P).$$

Remark 4.8. The value $v_{\overline{d}}^a(D_j)$ is the part of the non-dicritical valence of D_j related to its ancestors, i.e., to components \mathcal{D}_r where P_r is an ancestor of P_{j-1} . It always satisfies $v_{\overline{d}}^a(D_j) \leq c \leq 2$, where c is the number of irreducible components of E_{j-1} containing the point P_{j-1} . For $j = 1$, one always has $c = 0$.

With this convention, the sum (4.1) can be regrouped in the following way:

$$(4.2) \quad \sum_{D_j \notin \text{Inv}(E_k)} w(D_j)(2 - v_{\overline{d}}(D_j)) = 1 + \sum_{P_l \text{ s.c.}} (-\delta(P_l)w(D(P_l))) + \sum_{D_j \notin \text{Inv}(E_k)} w(D_j)(2 - v_{\overline{d}}^a(D_j)).$$

Notice the term 1 in the right-hand side of equation (4.2): it is required in order to remove the “spurious” $-\delta(P_0)w(D(P_0))$, as $D(P_0) = \emptyset$. However, it is exactly what will cancel the +1 in Hertling’s formula (2.3).

At this point, we proceed to study each component \mathcal{D}_l in isolation. The positive contributions in Hertling’s formula (2.3) pertaining to a specific component \mathcal{D}_l are easily bounded in terms of either $\hat{\Gamma}$ or P_l :

Lemma 4.9. *With the notations above, if $\hat{\Gamma}$ is weakly isolated for \mathcal{F} and P_l is a separating center, then*

$$(4.3) \quad \sum_{\substack{D \in \mathcal{D}_l \\ P \in D}} w(D) \kappa_P(\mathcal{F}_k, D) \geq \sum_{j=1}^{n_l} v_0(\gamma^{l,j}).$$

Also, for any $H \in \mathcal{I}$ with $H \subset \mathcal{D}_l$,

$$(4.4) \quad \sum_{D_j \in H} \sum_{P \in D_j} w(D_j) \kappa_P(\mathcal{F}_k, D_j) \geq w(D(P_l)).$$

Proof. The first inequality holds because $\kappa_{P_j^l}(\mathcal{F}', D) \geq 1$ at $\{P_j^l\} = \gamma_k^{l,j} \cap E$ by hypothesis, and $v_0(\gamma^{l,j}) = w(D(P_j^l))$, where $D(P_j^l)$ is the unique irreducible component of E that contains P_j^l . The second one follows from Remark 2.16. ■

We now study each controllable part. Define, for a separating center P_l ,

$$\mathcal{E}_l = \sum_{D_j \in \mathcal{D}_l} \sum_{P \in D_j} w(D_j) \kappa_P(\mathcal{F}_k, D_j) - \delta(P_l)w(D(P_l)) + \sum_{\substack{D_j \notin \text{Inv}(E_k) \\ D_j \in \mathcal{D}_l}} w(D_j) (2 - v_d^a(D_j))$$

(the part of Hertling’s formula corresponding to \mathcal{D}_l). Notice that we do not care if $l = 0$ or not in this definition. The following result is the crux of this section.

Lemma 4.10. *With the notations above, $\mathcal{E}_l \geq w(D(P_l))$ and*

$$(4.5) \quad \mathcal{E}_l \geq \frac{1}{2} \sum_{j=1}^{n_l} v_0(\gamma^{l,j}) + \frac{1}{2} \sum_{j=1}^{m_l} v_0(\bar{\gamma}^{l,j}).$$

Proof. Denote by P_j^l the intersection $P_j^l = \gamma_k^{l,j} \cap E$ (and the same for \bar{P}_j^l and $\bar{\gamma}^{l,j}$). Since $(\pi_{l+1} \circ \dots \circ \pi_k)(P_j^l) = P_l$ and the analogous property for $\bar{\gamma}_k^{l,r} \cap E$ holds, it follows that the multiplicities of the $\gamma^{l,j}$ and $\bar{\gamma}^{l,r}$ are integer multiples of $w(D(P_l))$ for all $1 \leq j \leq n_l$ and $1 \leq r \leq m_l$.

The first center P_0 is special because it has no ancestor. Thus, the case D_1 non-invariant needs to be studied separately. In this case, the unique divisor in \mathcal{D}_0 is D_1 and we get

$$\mathcal{E}_0 \geq \sum_{j=1}^{n_0} v_0(\gamma^{0,j}) + 1 \geq \frac{1}{2} \sum_{j=1}^{n_0} v_0(\gamma^{0,j}) + 1 \geq \frac{1}{2} \sum_{j=1}^{n_0} v_0(\gamma^{0,j}) + \frac{1}{2} \sum_{j=1}^{m_0} v_0(\bar{\gamma}^{0,j})$$

by equation (4.3), and this case is finished.

If $l > 0$ or D_1 is invariant, then $\bar{\gamma}^{l,1}, \dots, \bar{\gamma}^{l,m_l}$ intersect \mathcal{D}_l in m_l non-invariant divisors $D_{r_1}, \dots, D_{r_{m_l}}$ that satisfy $v_d^a(D_{r_\ell}) \leq 1$ for $1 \leq \ell \leq m_l$, since the irreducible components of $\bar{\Gamma}$ are smooth, by Remark 4.8. Using equation (4.3), we deduce

$$(4.6) \quad \begin{aligned} \mathcal{E}_l &\geq \sum_{j=1}^{n_l} v_0(\gamma^{l,j}) + \sum_{\ell=1}^{m_l} w(D(P_l))(2 - v_d^a(D_{r_\ell})) - w(D(P_l)) \\ &\geq \sum_{j=1}^{n_l} v_0(\gamma^{l,j}) + \sum_{j=1}^{m_l} v_0(\bar{\gamma}^{l,j}) - w(D(P_l)). \end{aligned}$$

Notice that $w(D(P_l)) = 1$ if $m_l \geq 1$ since $\bar{\Gamma}$ consists of smooth branches. The inequality (4.5) holds whenever

$$(4.7) \quad \sum_{j=1}^{n_l} v_0(\gamma^{l,j}) + \sum_{j=1}^{m_l} v_0(\bar{\gamma}^{l,j}) \geq 2w(D(P_l)).$$

Since the desingularization of $\Gamma \cup \bar{\Gamma}$ is minimal, (4.7) holds if no descendant Q of P_l is a separating center. Assume, then, that P_l does not satisfy property (4.7) and hence P_l has a descendant which is a separating center. Since (4.7) does not hold and the left-hand side is a multiple of $w(D(P_l))$, it follows that it is less than or equal to $w(D(P_l))$. Thus, it suffices to show that $\mathcal{E}_l \geq w(D(P_l))$.

The hypothesis on P_l implies that there exists a non-invariant divisor D_ℓ in \mathcal{D}_l . This gives

$$(4.8) \quad \mathcal{E}_l \geq \sum_{D_j \in \mathcal{D}_l} \sum_{P \in D_j} w(D_j) \kappa_P(\mathcal{F}_k, D_j) + (2 - v_d^a(D_\ell) - \delta(P_l)) w(D(P_l)).$$

Since \mathcal{D}_l contains at least $v_d^a(D_\ell)$ elements of \mathcal{J} , then

$$\mathcal{E}_l \geq (2 - \delta(P_l)) w(D^l) \geq w(D^l)$$

by equation (4.4), and the result follows. ■

The main result of this section is now straightforward. It is Theorem 1.2, that we restate here for the sake of the reader.

Theorem 4.11. *Let $\hat{\Gamma}$ be a weakly isolated curve for \mathcal{F} , where \mathcal{F} is a germ of holomorphic foliation \mathcal{F} defined in a neighborhood of the origin in \mathbb{C}^2 . Then $v_0(\mathcal{F}) \geq v_0(\hat{\Gamma})/2$.*

Proof. We have

$$\begin{aligned} v_0(\mathcal{F}) &= \sum_{D_j} \sum_{P \in D_j} w(D_j) \kappa_P(\mathcal{F}_k, D_j) - \sum_{P \text{ s.c.}} \delta(P_l) w(D(P_l)) \\ &\quad + \sum_{D_j \notin \text{Inv}(E_k)} w(D_j) (2 - v_d^a(D_j)), \end{aligned}$$

by Hertling’s formula (2.3) and equation (4.2). Since the union of the \mathcal{D}_l is the set of irreducible components of the exceptional divisor E_k of π , and $\mathcal{D}_l \cap \mathcal{D}_j$ is at most a point for $l \neq j$ and hence does not contain an irreducible component of E_k , we get

$$\nu_0(\mathcal{F}) = \sum_{P_l \text{ s.c.}} \mathcal{E}_l.$$

We deduce

$$\nu_0(\mathcal{F}) = \sum_{P_l \text{ s.c.}} \mathcal{E}_l \geq \frac{1}{2} \sum_{P_l \text{ s.c.}} \left(\sum_{j=1}^{n_l} \nu_0(\gamma^{l,j}) + \sum_{j=1}^{m_l} \nu_0(\bar{\gamma}^{l,j}) \right) = \frac{\nu_0(\hat{\Gamma})}{2},$$

where the inequality is a consequence of Lemma 4.10. ■

We want to stress again that the structure of \mathcal{F} along E_k is totally irrelevant except for the property that $\hat{\Gamma}$ is weakly isolated, which only affects the intersection points of $\hat{\Gamma}_k$ and E_k along the resolution of singularities of $\hat{\Gamma}$. The argument works whatever the family of separating centers P_l is and whatever non-invariant irreducible components of E_k are for \mathcal{F}_k , as long as the weakly isolation holds.

The previous result provides a lower bound for the multiplicity of the foliation in terms of the multiplicity of an invariant curve, but we do not require that all irreducible components are isolated. This will be very useful in desingularization settings in which invariant divisors cannot be assumed to be isolated for the foliations $\mathcal{F}_1, \dots, \mathcal{F}_k$.

Remark 4.12. Let us remark that in [7], they proved that $M\nu_0(\mathcal{F}) \geq \nu_0(\Gamma)$ for some $M > 0$ in the isolated case. We have shown that $M \leq 2$.

5. Global Poincaré problem

In the previous sections, we studied the Poincaré problem in the local setting. We want to apply Theorem 4.11 to obtain linear lower bounds for the multiplicity of a foliation in terms of the multiplicity of an invariant curve.

We consider an algebraic curve Γ in $\mathbf{CP}(2)$ that is invariant by a foliation \mathcal{F} . Carnicer’s solution [4] of the Poincaré problem for the case where the curve Γ does not contain dicritical singularities of \mathcal{F} relies on showing the following local property: let \mathcal{F} be a germ of non-dicritical foliation that preserves the curve Γ . Consider a reduced equation $f \in \mathcal{O}_2$ of Γ and the foliation \mathcal{H} given by the first integral f . Then we always have

$$Z_P(\mathcal{F}, \gamma) \geq Z_P(\mathcal{H}, \gamma)$$

for any $P \in \Gamma$ and any branch γ of Γ defined in a neighborhood of P . In order to obtain lower bounds for $\nu_0(\mathcal{F})$, we need to bound $Z_P(\mathcal{F}, \gamma)/Z_P(\mathcal{H}, \gamma)$ from below.

Let us see one of the difficulties. Consider an irreducible curve Γ . Suppose now that $\nu_0(\Gamma)/\mu(\Gamma) \leq M$ for some $M \in \mathbb{N}$. In such a case, the quotient $\nu_0(\mathcal{F})/\nu_0(\mathcal{H})$ is bounded from below by a positive constant; indeed, we have

$$\frac{\nu_0(\mathcal{F})}{\nu_0(\mathcal{H}) + 1} = \frac{\nu_0(\mathcal{F})}{\nu_0(\Gamma)} = \frac{\nu_0(\mathcal{F})}{\mu(\Gamma)} \frac{\mu(\Gamma)}{\nu_0(\Gamma)} \geq \frac{1}{M}$$

by equation (3.1). Notice that $\nu_0(\mathcal{H}) = \nu_0(\Gamma) - 1$ since \mathcal{H} is a generalized curve [2]. This motivates us to study whether in such a case $Z_P(\mathcal{F}, \Gamma)/Z_P(\mathcal{H}, \Gamma)$ could be bounded from below by a positive constant. Next we show that this is not the case.

Example 5.1. Consider the curve Γ given by the equation $y^2 = x^p$, where $p \geq 3$ is an odd number. The map $\theta(t) = (t^2, t^p)$ is a Puiseux parametrization of Γ . The multiplicities of Γ are $\nu_0(\Gamma) = 2$ and $\mu(\Gamma) = 1$. Consider the foliation \mathcal{F} that has the first integral y^2/x^p . It is the foliation defined by the vector field $X = 2x \partial/\partial x + py \partial/\partial y$. Since

$$d\theta(t)\left(t \frac{\partial}{\partial t}\right) = 2t^2 \frac{\partial}{\partial x} + pt^p \frac{\partial}{\partial y} = X(\theta(t)),$$

we obtain $\theta^*X = t\partial/\partial t$ and $Z_0(\mathcal{F}, \Gamma) = 1$. The vector field $Y := 2y \partial/\partial x + px^{p-1} \partial/\partial y$ is tangent to foliation as $d(y^2 - x^p) = 0$. Since

$$d\theta(t)\left(t^{p-1} \frac{\partial}{\partial t}\right) = 2t^p \frac{\partial}{\partial x} + pt^{2p-2} \frac{\partial}{\partial y} = Y(\theta(t)),$$

we get $Z_0(\mathcal{H}, \Gamma) = p - 1$. Hence, even in the case where $\nu_0(\Gamma)/\mu(\Gamma) = 2$, the quotient $Z_0(\mathcal{F}, \Gamma)/Z_0(\mathcal{H}, \Gamma)$ is not bounded from below by a positive constant.

As a consequence of Theorem 1.3, the situation is different for weakly isolated invariant curves. Assume for now that Theorem 1.3 holds, and that the simpler Lemma 5.11 does too, to prove Theorem 1.4.

Proof of Theorem 1.4 assuming Theorem 1.3 and Lemma 5.11. We can consider that the line L_∞ at ∞ is generic. In particular, L_∞ is not \mathcal{F} -invariant, $L_\infty \cap \text{Sing}(\mathcal{F}) = \emptyset$, and Γ intersects L_∞ transversally. We denote by (x, y) the coordinates in the affine chart $\mathbf{CP}(2) \setminus L_\infty$. Let F be a polynomial vector field, with $\text{cod}(\text{Sing}(F)) \geq 2$, defining the foliation \mathcal{F} in the affine chart $\mathbf{CP}(2) \setminus L_\infty$. We consider an irreducible equation $f \in \mathbb{C}[x, y]$ of the curve Γ in $\mathbf{CP}(2) \setminus L_\infty$. Let \mathcal{H} be the foliation given by the hamiltonian vector field $H := \partial f/\partial y \cdot \partial/\partial x - \partial f/\partial x \cdot \partial/\partial y$.

Consider the normalization $\pi: \hat{\Gamma} \rightarrow \Gamma$. We lift F and H to the smooth compact Riemann surface $\hat{\Gamma}$. We denote by c the number of irreducible components of Γ ; it coincides with the number of connected components of $\hat{\Gamma}$. We define

$$Z_P(\mathcal{F}) = Z_{\pi(P)}(\mathcal{F}, \pi(\hat{\Gamma}, P)) \quad \text{and} \quad Z_P(\mathcal{H}) = Z_{\pi(P)}(\mathcal{H}, \pi(\hat{\Gamma}, P))$$

for $P \in \hat{\Gamma}$, where $\pi(\hat{\Gamma}, P)$ is the germ of $\pi(\hat{\Gamma})$ at P . We claim that $Z_Q(\mathcal{F}) \geq Z_Q(\mathcal{H})/2$ for any $Q \in \hat{\Gamma}$. This is a consequence of $Z_Q(\mathcal{H}) = 0$ if $\pi(Q)$ is a regular point of Γ . In the singular case, we apply Theorem 1.3.

We apply Poincaré–Hopf’s theorem to the restrictions of F and H to Γ . If we denote by Z_F and P_F the number of zeros and poles (with multiplicity) of $F|_\Gamma$, we obtain

$$Z_F - P_F = Z_H - P_H = \chi(\hat{\Gamma}),$$

where χ stands for the Euler characteristic. We have $Z_F \geq Z_H/2$ by the previous discussion. Moreover, it is well known that $P_H = m(m - 3)$ and $P_F = m(d - 1)$, where

$m = \deg(\Gamma)$ and $d = \deg(\mathcal{F})$ (see Proposition 25.22 in [12]). We have

$$m(d - 1) = P_H + Z_F - Z_H \geq P_H - \frac{Z_H}{2} = \frac{P_H}{2} - \frac{\chi(\hat{\Gamma})}{2} \geq \frac{m(m - 3)}{2} - c,$$

and then

$$(5.1) \quad d \geq \frac{m - 3}{2} - \frac{c}{m} + 1 = \frac{m}{2} - \frac{c}{m} - \frac{1}{2}.$$

Assume $c < m$. We deduce

$$m \leq 2d + \frac{2c}{m} + 1 < 2d + 3.$$

It follows that $m \leq 2d + 2$.

Consider the remaining case $c = m$. Thus, all irreducible components of Γ have degree 1, i.e., they are lines. We have $Z_F \geq Z_H$ by Lemma 5.11, and hence

$$m(d - 1) = P_H + Z_F - Z_H \geq P_H = m(m - 3) \implies m \leq d + 2.$$

Therefore we get $m \leq d + 2 \leq 2d + 2$.

Finally, assume that Γ is irreducible. Since $d = 0$ implies $m = 1$, we can assume $d \geq 1$. Therefore $m \leq 2d + 1$ holds if $m \leq 3$. So, it suffices to consider $m \geq 4$. Since

$$m \leq 2d + \frac{2c}{m} + 1 = 2d + \frac{2}{m} + 1 < 2d + 2,$$

it follows that $m \leq 2d + 1$. ■

Remark 5.2. Consider a foliation \mathcal{F} of $\mathbf{CP}(2)$ of degree 0, and let P be its unique singular point. Notice that the unique invariant curves Γ that satisfy our hypothesis are either a line through P or two lines through P . In the former case, we have $\deg(\Gamma) = 1 = 2 \deg(\mathcal{F}) + 1$, whereas in the latter case we obtain $\deg(\Gamma) = 2 = 2 \deg(\mathcal{F}) + 2$.

5.1. Comparison of vanishing orders

We show Theorem 1.3 in the remaining of the paper. Let us assume that \mathcal{F} is a germ of foliation defined in a neighborhood of $(0, 0)$ in \mathbb{C}^2 without lack of generality. We desingularize Γ along an irreducible component γ of Γ . Consider the notations in Definition 2.9. In this case, $\pi_1, \pi_2, \dots, \pi_k$ is a sequence of blow-ups of infinitely near points of γ .

Definition 5.3. We say that π is a desingularization of Γ along γ if γ_k intersects the divisor transversally at the non-corner point P_k of E_k , and the germs of γ_k and Γ_k at P_k coincide. We assume that π is minimal with such a property.

Remark 5.4. The previous property is not equivalent to a desingularization of γ . For instance, if γ is smooth and Γ is not, we need to blow-up the origin since $\Gamma_0 \neq \gamma_0$.

By applying iteratively equations (2.5) and (2.6), we obtain

$$(5.2) \quad Z_0(\mathcal{F}, \gamma) = v_0^\gamma \tau_0 + \dots + v_{j-1}^\gamma \tau_{j-1} + Z_{P_j}(\mathcal{F}_j, \gamma_j)$$

for any $0 \leq j \leq k$, where $v_j^\gamma = v_{P_j}(\gamma_j)$ and $\tau_j = v_{P_j}(\mathcal{F}_j)$ if \mathcal{F}_j is 1-dicritical at P_j and $\tau_j = v_{P_j}(\mathcal{F}_j) - 1$ otherwise.

Since \mathcal{H} is non-dicritical, we get, for any $0 \leq j \leq k$,

$$Z_0(\mathcal{H}, \gamma) = v_0^\gamma(v_{P_0}(\mathcal{H}_0) - 1) + \cdots + v_{j-1}^\gamma(v_{P_{j-1}}(\mathcal{H}_{j-1}) - 1) + Z_{P_j}(\mathcal{H}_j, \gamma_j).$$

Remark 5.5. The germ of \mathcal{H}_j at any point is a generalized curve; therefore we get

$$v_{P_j}(\mathcal{H}_j) = v_{P_j}(\tilde{\pi}_j^{-1}(\Gamma)) - 1 = v_{P_j}(\Gamma_j) + m_j - 1,$$

where m_j is the number of irreducible components of E_j containing P_j (see [2]). Notice that $m_j = 0$ if $j = 0$. We obtain

$$Z_0(\mathcal{H}, \gamma) = \sum_{l=0}^{j-1} v_l^\gamma(v_{P_l}(\tilde{\pi}_l^{-1}(\Gamma)) - 2) + Z_{P_j}(\mathcal{H}_j, \gamma_j)$$

for any $0 \leq j \leq k$, where $\tilde{\pi}_0^{-1}(\Gamma) = \Gamma$ by convention. Notice that $v_{P_l}(\tilde{\pi}_l^{-1}(\Gamma)) - 2 \leq v_{P_l}(\Gamma_l)$ for $0 \leq l \leq k$.

Remark 5.6. Given $0 \leq j < k$, we have $\tau_j \geq v_{P_j}(\mathcal{F}_j) - 1$. As we are going to use equation (5.2) to obtain lower bounds of $Z_0(\mathcal{F}, \gamma)$, we want to consider points P_j that have a non-negative contribution τ_j to equation (5.2). Indeed, we will consider points P_j with $v_{P_j}(\mathcal{F}_j) \geq 1$. This motivates the next definition.

Definition 5.7. Let $I = \{0, 1, \dots, k - 1\}$ be the set of indices of blow-up centers, and consider those where Γ_l has multiplicity 1:

$$I_1 = \{l \in I : v_{P_l}(\Gamma_l) = 1\}.$$

Define ι as the maximum element of I with $v_\iota^\gamma = v_{P_\iota}(\gamma_\iota) > 1$ (if $I_1 = \emptyset$, then ι is irrelevant and can be defined as -1). We set $\Omega_1 = I_1$ if $\iota \geq 0$ and $D_{\iota+1}$ is non-invariant, and $\Omega_1 = \emptyset$ otherwise. We define $\rho = \min(I_1 \cup \{k\}) - 1$ (that is, the last index such that $v_{P_\rho}(\Gamma_\rho) > 1$).

Remark 5.8. The set I_1 is the “final stage” in the resolution of singularities of both γ and Γ : for $j \in I_1$, the germs (Γ_j, P_j) and (γ_j, P_j) in $\tilde{\pi}_j^{-1}(\mathbb{C}^2)$ coincide, P_j is of multiplicity 1 (for both of them, obviously), and it is also the corner $D_j \cap D_{\iota+1}$. The set Ω_1 is non-empty if and only if $D_{\iota+1}$ is non-invariant. In this case, for $j \in \Omega_1 = I_1$, P_j always belongs to at least one non-invariant component of E_j .

Also, $I_1 \neq \emptyset$ implies that γ is a singular curve (otherwise, as soon as $v_{P_j}(\Gamma_j) = 1$, we should have $j = k$, so that $I_1 = \emptyset$).

Remark 5.9. We have that $v_{P_j}(\mathcal{F}_j) \geq 1$ if $j \in I \setminus \Omega_1$. This is clear if $j \in I \setminus I_1$, since $v_{P_j}(\Gamma_j) \geq 2$. Moreover, it also holds if $j \in I_1 \setminus \Omega_1$, since there are two invariant curves in $\tilde{\pi}_j^{-1}(\mathbb{C}^2)$, namely Γ_j and $D_{\iota+1}$, containing P_j . This is what makes Ω_1 so important: it contains the “worst” centers in terms of lower bounds for $v_{P_j}(\mathcal{F}_j)$; this will become clear as we proceed.

Before continuing, notice that the inequality we wish to prove can be written, by Remark 5.5, as

$$(5.3) \quad \frac{v_0^\gamma \tau_0 + \cdots + v_\rho^\gamma \tau_\rho + Z_{P_{\rho+1}}(\mathcal{F}_{\rho+1}, \gamma_{\rho+1})}{\sum_{j=0}^{k-1} v_j^\gamma (v_{P_j}(\tilde{\pi}_j^{-1}(\Gamma)) - 2) + Z_{P_k}(\mathcal{H}_k, \gamma_k)} \geq \frac{1}{2}.$$

We are going to partition both numerator and denominator of the left-hand side and verify that, for each of the sets of the partition, the corresponding sums are both positive and satisfy the inequality, and that will finish the argument.

First of all, let us consider the last terms of the case $I_1 = \emptyset$.

Lemma 5.10. $Z_{P_k}(\mathcal{H}_k, \gamma_k) = 1$, and if D_k is invariant, $Z_{P_k}(\mathcal{F}_k, \gamma_k) \geq 1$.

Proof. The pair $(\mathcal{H}_k, \gamma_k)$ is analytically conjugated in a neighborhood of P_k to the pair $(d(x^p y^q) = 0, y = 0)$, where $p, q \geq 1$. We obtain $Z_{P_k}(\mathcal{H}_k, \gamma_k) = 1$. If D_k is invariant, then $Z_{P_k}(\mathcal{F}_k, \gamma_k) \geq 1$ since P_k is a singular point. ■

The following result was used in the proof of Theorem 1.4 to improve an inequality.

Lemma 5.11. Let Γ be a weakly isolated curve composed of pairwise transverse smooth branches. Then $Z_0(\mathcal{F}, \gamma) \geq Z_0(\mathcal{H}, \gamma) \geq 1$ for any irreducible component γ of Γ .

Proof. We have

$$Z_0(\mathcal{H}, \gamma) = (v_0(\mathcal{H}) - 1) + Z_{P_1}(\mathcal{H}_1, \gamma_1) = (v_0(\Gamma) - 2) + 1 = v_0(\Gamma) - 1.$$

Assume D_1 is invariant. We have $Z_{P_1}(\mathcal{F}_1, \gamma_1) \geq 1$ and

$$Z_0(\mathcal{F}, \gamma) = \tau_0 + Z_{P_1}(\mathcal{F}_1, \gamma_1) \geq v_0(\mathcal{F}) = \sum_{P \in D_1} Z_P(\mathcal{F}, D_1) - 1 \geq v_0(\Gamma) - 1,$$

since $Z_{P_{\gamma'}}(\mathcal{F}, D_1) \geq 1$ for any irreducible component γ' of Γ .

Assume D_1 is non-invariant. We have

$$Z_0(\mathcal{F}, \gamma) \geq \tau_0 = v_0(\mathcal{F}) = 1 + \sum_{P \in D_1} \text{tang}_P(\mathcal{F}, D_1) \geq 1 + (v_0(\Gamma) - 2)$$

by the weak isolation hypothesis. In any case, $Z_0(\mathcal{F}, \gamma) \geq v_0(\Gamma) - 1 = Z_0(\mathcal{H}, \gamma)$. ■

Definition 5.12. Let $0 \leq j \leq k$. From now on, F_j will denote the union of the (at most two, obviously) irreducible components of E_j containing P_j , and F'_j its subset of invariant irreducible components. We denote by m_j be the number of irreducible components of F_j .

Remark 5.13. We are going to apply Theorem 4.11 at P_j for $j \in I \setminus \Omega_1$ to obtain lower bounds for τ_j . This approach works since weak isolation is invariant by blow-ups by Proposition 4.4.

The next lemma measures the contribution of each term to the required inequality whenever $j \notin \Omega_1$.

Lemma 5.14. Let $j \in I \setminus \Omega_1$. Let

$$\theta_j = \tau_j - \frac{1}{2}(v_{P_j}(\mathcal{H}_j) - 1).$$

Then $\theta_j \geq -1$. Moreover, the following non-exclusive statements hold:

- If $F_j = F'_j$, then $\theta_j \geq 0$ (this contains the case $j = 0$).
- If \mathcal{F}_j is 1-dicritical at P_j , then $\theta_j \geq 0$.
- If $F_j = F'_j$ and \mathcal{F}_j is 1-dicritical at P_j , then $\theta_j \geq 1$.

Proof. We have $v_j(\mathcal{H}_j) - 1 = v_{P_j}(\Gamma_j) + m_j - 2$ by Remark 5.5. Since

$$\tau_j \geq v_{P_j}(\mathcal{F}_j) - 1 \geq \frac{1}{2} v_{P_j}(\Gamma_j) - 1$$

by Theorem 4.11, Remarks 5.9 and 5.13 and $v_{P_j}(\Gamma_j) \geq v_{P_j}(\mathcal{H}_j) - 1$, we obtain $\theta_j \geq -1$. Now we prove each of the statements.

- If $F_j = F'_j$, then

$$\tau_j \geq \frac{1}{2} (v_{P_j}(\Gamma_j) + m_j) - 1 \geq \frac{1}{2} (v_j(\mathcal{H}_j) - 1)$$

by Theorem 4.11 and Remarks 5.9 and 5.13, from which $\theta_j \geq 0$ follows (the case $j = 0$ is covered because Γ is singular at $(0, 0)$, which implies that $v_j(\mathcal{H}_j) \geq 1$).

- If \mathcal{F}_j is 1-dicritical at P_j , then we have $\tau_j = v_{P_j}(\mathcal{F}_j) \geq \frac{1}{2} v_{P_j}(\Gamma_j)$ by Theorem 4.11 and Remark 5.13, and $\theta_j \geq 0$ follows from $v_{P_j}(\Gamma_j) \geq v_{P_j}(\mathcal{H}_j) - 1$.
- Finally, if $F_j = F'_j$ and \mathcal{F}_j is 1-dicritical at P_j , then we obtain

$$\tau_j = v_{P_j}(\mathcal{F}_j) \geq \frac{1}{2} (v_{P_j}(\Gamma_j) + m_j) = \frac{1}{2} (v_{P_j}(\mathcal{H}_j) - 1) + 1$$

by Theorem 4.11 and Remark 5.13, and hence $\theta_j \geq 1$.

The proof is complete. ■

Definition 5.15. Given a subset S of $I \setminus \Omega_1$, we define

$$\Theta_S = \sum_{m \in S} v_m^\gamma \tau_m - \frac{1}{2} \sum_{m \in S} v_m^\gamma (v_{P_m}(\mathcal{H}_m) - 1).$$

We now divide the sequence $(P_j)_{j \in I \setminus \Omega_1}$ into “satisfactory” subsequences. Assume $I \setminus \Omega_1 = \bigcup_{i=1}^\ell S_i$, with $S_i \cap S_j = \emptyset$ if $i \neq j$. We will estimate Θ_{S_i} for each $i \in \{1, \dots, \ell\}$, and these estimates will essentially imply Theorem 1.3. The following definitions provide the required partition.

Definition 5.16. Let $0 \leq j \leq k$. We say that P_j is a *precursor point* if $j \in I \setminus \Omega_1$ and at least one of the following non-exclusive properties holds:

- D_{j+1} is non-invariant and $v_{j+1}^\gamma < v_j^\gamma$;
- D_{j+1} is non-invariant and it is the unique non-invariant divisor containing P_{j+1} in E_{j+1} ;
- every irreducible component of E_j containing P_j is invariant.

We say that P_j is a *leader point* if it is a precursor point such that $F_j = F'_j$.

A precursor point P_j either only belongs to invariant divisors, or (non-exclusively) marks the start of a chain P_j, \dots, P_r of blow-ups such that D_{j+1} is non-invariant, and for $l \in \{j + 1, \dots, r\}$, the curve γ_l intersects D_{j+1} or more precisely, its strict transform by $\pi_{j+2} \circ \dots \circ \pi_l$ if $l > j + 1$ (an important well-known consequence is that the multiplicity of γ_l at P_l is constant for $l \in \{j + 1, \dots, r - 1\}$).

Definition 5.17. We define a partition \mathcal{P}' of the set $I \setminus \Omega_1$ as follows: a set $\{j, \dots, r\}$ belongs to \mathcal{P}' if P_j is a leader, P_{j+1}, \dots, P_r are non-leaders, and either P_{r+1} is a leader or $r + 1 \notin I \setminus \Omega_1$. Replacing “leader” with “precursor”, we obtain another partition \mathcal{P} that is finer than \mathcal{P}' .

Notice that if $\iota > -1$ (cf. Definition 5.7) and $\Omega_1 \neq \emptyset$, then P_l is always a precursor. Finally, *roughly speaking*, the sets in \mathcal{P} are usually singletons, unless there are specific chains of dicritical divisors.

As pointed out above, the sets of the partition \mathcal{P} are all well-behaved with respect to (5.3).

Lemma 5.18. *Let $S = \{j, \dots, r\}$ be a set of the partition \mathcal{P} . Set $\delta = 1$ if $F_j = F'_j$, and $\delta = 0$ otherwise. Then we have*

- $\Theta_S \geq (\delta - 1)v_j^\gamma$ in any case;
- $\Theta_S \geq v_{r+1}^\gamma + (\delta - 1)v_j^\gamma$ if D_{j+1} is non-invariant and $F_{r+1} \neq F'_{r+1}$;
- $\Theta_S \geq 0$ if D_{j+1} is invariant.

Proof. We consider the two alternatives: D_{j+1} non-invariant or invariant. As usual, we identify D_{j+1} with its strict transforms for the sake of simplicity. So for instance, when we say $P_s \notin D_{j+1}$ for some $s > j + 1$, we mean that P_s is not in the strict transform of D_{j+1} by $\pi_{j+2} \circ \dots \circ \pi_s$.

Case D_{j+1} non-invariant. Consider the sequence P_{j+1}, \dots, P_s of infinitely near points of γ that belong to D_{j+1} . We claim that $r \leq s$. Assume $r \geq s + 1$, aiming at contradiction. This implies that P_s and P_{s+1} are not precursors, by definition of the partition \mathcal{P} . We distinguish two cases:

- If D_s is invariant or $s = j + 1$, then D_{j+1} is the unique non-invariant divisor containing P_s (in the latter case, it is a consequence of $v_j^\gamma = v_{j+1}^\gamma$ and the definition of precursor point). Now, if D_{s+1} is non-invariant then P_s is a precursor since $P_{s+1} \notin D_{j+1}$ (contradiction). Otherwise, if D_{s+1} is invariant, then P_{s+1} is a precursor, providing also a contradiction.
- If, on the contrary, D_s is non-invariant and $s > j + 1$, then, since P_{s-1} is not a precursor point, we obtain $v_{s-1}^\gamma = v_s^\gamma$, and as a consequence, P_{s+1} does not belong neither to D_{j+1} nor to D_s . We obtain a contradiction since P_s is a precursor if D_{s+1} is non-invariant and P_{s+1} is a precursor otherwise.

The equality $v_j^\gamma = \sum_{l=j+1}^s v_l^\gamma$ is a direct consequence of the fact that P_{j+1}, \dots, P_s belong to D_{j+1} and P_{s+1} does not. By Lemma 5.14, we obtain $\Theta_S \geq \delta v_j^\gamma - \sum_{l=j+1}^r v_l^\gamma$, and hence

$$\Theta_S \geq \delta v_j^\gamma - \sum_{l=j+1}^r v_l^\gamma \geq \delta v_j^\gamma - \sum_{l=j+1}^s v_l^\gamma = (\delta - 1)v_j^\gamma,$$

using that $r \leq s$ and Lemma 5.14. There are two subcases to consider.

If $r < s$ or D_{l+1} is non-invariant for some $j + 1 \leq l \leq r$, then the inequality $\Theta_S \geq v_{r+1}^\gamma + (\delta - 1)v_j^\gamma$ follows by Lemma 5.14.

On the other hand, if $r = s$ and D_{l+1} is invariant for all $j + 1 \leq l \leq r$, we obtain $F_{r+1} = F'_{r+1}$, which concludes this case.

Case D_{j+1} invariant. This implies $F_j = F'_j$ by Definition 5.16, and either $j+1 \notin I \setminus \Omega_1$ or P_{j+1} is a precursor, and hence $S = \{j\}$ in both cases. The result is a consequence of Lemma 5.14. ■

Lemma 5.19. *Let $S = \{j, \dots, r\}$ be a set of the partition \mathcal{P}' which is the union of consecutive sets S_1, \dots, S_m of \mathcal{P} . Then the following inequalities hold:*

$$(5.4) \quad \Theta_S = \sum_{l=1}^m \Theta_{S_l} \geq 0 \quad \text{and} \quad \sum_{l=1}^p \Theta_{S_l} \geq v_{1+\max S_p}^\gamma$$

if $1 \leq p < m$ or if $p = m$ and $F_{1+r} \neq F'_{1+r}$ (the latter condition can only happen if $r = \max(I \setminus \Omega_1)$). In particular, we obtain $\Theta_S \geq v_{1+r}^\gamma$ if $F_{1+r} \neq F'_{1+r}$.

Proof. There are two cases, depending on whether D_{j+1} is invariant or not.

If D_{j+1} is invariant, then, by definition of leader point $m = 1$, $S_1 = \{j\}$ and, by Lemma 5.18, $\Theta_{S_1} \geq 0$. The second part holds because the condition is empty (there is no $1 \leq p < m$ and $F_{1+r} = F'_{1+r}$).

Assume that D_{j+1} is non-invariant. Denote $\delta = 1$ if $F_{1+r} \neq F'_{1+r}$ and $\delta = 0$ otherwise. If $m = 1$, then $\Theta_{S_1} \geq \delta v_{1+r}^\gamma$ straightforwardly by Lemma 5.18. Suppose, then, that $m > 1$. Then Lemma 5.18 implies the inequalities

$$\begin{aligned} \Theta_{S_1} &\geq v_{1+\max S_1}^\gamma, \\ \Theta_{S_l} &\geq -v_{\min S_l}^\gamma + v_{1+\max S_l}^\gamma \quad \text{for any } 1 < l < m, \text{ and} \\ \Theta_{S_m} &\geq -v_{\min S_m}^\gamma + \delta v_{1+\max S_m}^\gamma. \end{aligned}$$

A telescopic argument concludes the proof of the claim. ■

At this point, we have all the machinery required to prove Theorem 1.3.

5.2. Proof of Theorem 1.3

By definition, we have $\rho \geq \iota$, as γ is a branch of Γ . We are going to compare

$$Z_0(\mathcal{F}, \gamma) = \sum_{l=0}^{\rho} v_l^\gamma \tau_l + Z_{P_{\rho+1}}(\mathcal{F}_{\rho+1}, \gamma_{\rho+1})$$

with

$$Z_0(\mathcal{H}, \gamma) = \sum_{j=0}^{k-1} v_j^\gamma (v_{P_j}(\mathcal{H}_j) - 1) + Z_{P_k}(\mathcal{H}_k, \gamma_k)$$

to get the inequality (see (2.5) and (2.6)). Recall the partition \mathcal{P}' of Definition 5.17. We will use the estimates in Lemma 5.19 for the sets of \mathcal{P}' . As a consequence, we obtain

$$(5.5) \quad \Theta_{I \setminus \Omega_1} \geq 0 \quad \text{and} \quad \Theta_{I \setminus \Omega_1} \geq 1 \quad \text{if } F_{1+\max(I \setminus \Omega_1)} \neq F'_{1+\max(I \setminus \Omega_1)}.$$

At this point, there are two cases to consider.

5.2.1. Case 1: $\Omega_1 = \emptyset$. We have $\Theta_I = \Theta_{I \setminus \Omega_1}$. It suffices to show that

$$\Theta_I + Z_{P_k}(\mathcal{F}_k, \gamma_k) - \frac{1}{2} Z_{P_k}(\mathcal{H}_k, \gamma_k) \geq 0.$$

Suppose that $F_k \neq F'_k$, i.e., D_k is non-invariant. Since $\Theta_I \geq 1$, by equation (5.5), and $Z_{P_k}(\mathcal{H}_k, \gamma_k) = 1$ and $Z_{P_k}(\mathcal{F}_k, \gamma_k) \geq 0$ hold, the inequality follows. Assume now that $F_k = F'_k$. Then, the inequality is a consequence of $Z_{P_k}(\mathcal{F}_k, \gamma_k) \geq Z_{P_k}(\mathcal{H}_k, \gamma_k) = 1$ (Lemma 5.10) and $\Theta_I \geq 0$.

5.2.2. Case 2: $\Omega_1 \neq \emptyset$. We have $\Omega_1 = I_1$ and D_{l+1} is non-invariant (Definition 5.7). The point P_l is a precursor by definition. Since the strict transform of D_{l+1} contains P_j for any $l < j < k$, it follows that no point P_ℓ with $\ell > l$ and $\ell \in I \setminus \Omega_1$ is a precursor. In particular, $S := \{l, \dots, \rho\}$ belongs to \mathcal{P} .

Consider the set S' of \mathcal{P}' containing S . By Lemma 5.19, we know that $\Theta_{S' \setminus S} \geq v_l^\gamma$ and hence $\Theta_{I \setminus (\Omega_1 \cup S)} \geq v_l^\gamma$ if $S \neq S'$. Moreover, we obtain $\Theta_{I \setminus (\Omega_1 \cup S)} \geq 0$ if $S = S'$, again by Lemma 5.19. Notice that $\tau_l = v_{P_l}(\mathcal{F}_l)$ since D_{l+1} is non-invariant. The previous discussion implies

$$\Theta_{I \setminus (\Omega_1 \cup S)} + v_l^\gamma \theta_l \geq v_l^\gamma$$

by Lemma 5.14. Therefore, we only need to show

$$\frac{v_l^\gamma + \sum_{l=i+1}^\rho \tau_l + Z_{P_{\rho+1}}(\mathcal{F}_{\rho+1}, \gamma_{\rho+1})}{\sum_{l=i+1}^{k-1} (v_{P_l}(\mathcal{H}_l) - 1) + Z_{P_k}(\mathcal{H}_k, \gamma_k)} \geq \frac{1}{2}.$$

By Lemma 5.14, the following inequality holds:

$$v_l^\gamma + \sum_{l=i+1}^\rho \tau_l \geq \frac{1}{2} \left(\sum_{l=i+1}^\rho (v_{P_l}(\mathcal{H}_l) - 1) \right) + v_l^\gamma - (\rho - l),$$

so that as $Z_{P_{\rho+1}}(\mathcal{F}_{\rho+1}, \gamma_{\rho+1}) \geq 0$, it suffices to show

$$(5.6) \quad \frac{v_l^\gamma - (\rho - l)}{\sum_{l \in I_1} (v_{P_l}(\mathcal{H}_l) - 1) + Z_{P_k}(\mathcal{H}_k, \gamma_k)} \geq \frac{1}{2}.$$

The denominator is at most $1 + \#I_1$ by Lemma 5.10 and Remark 5.5. On one hand, we have $v_l^\gamma \geq (\rho - l) + \#I_1$, and obviously $\#I_1 \geq 1$ in this case, because $I_1 = \Omega_1 \neq \emptyset$. This gives $2\#I_1 \geq \#I_1 + 1$, and equation (5.6) follows.

This completes the proof of Theorem 1.3.

Acknowledgements. We thank the referee for the reading and the helpful suggestions.

Funding. All authors are partially supported by the Ministerio de Ciencia e Innovación (Spain), Project Id. PID2019-105621GB-I00. The second author also by the Conselho Nacional de Desenvolvimento Científico e Tecnológico –CNPq, Proc. 308838/2019-0, and FAPERJ – Fundação Carlos Chagas Filho de Amparo à Pesquisa do Estado do Rio de Janeiro, Processo SEI 260003/003548/2022.

References

- [1] Brunella, M.: [Some remarks on indices of holomorphic vector fields](#). *Publ. Mat.* **41** (1997), no. 2, 527–544.
- [2] Camacho, C., Lins Neto, A. and Sad, P.: [Topological invariants and equidesingularization for holomorphic vector fields](#). *J. Differential Geom.* **20** (1984), no. 1, 143–174.
- [3] Cano, J. M., Fortuny Ayuso, P. and Ribón, J.: [The local Poincaré problem for irreducible branches](#). *Rev. Mat. Iberoam.* **37** (2021), no. 6, 2229–2244.
- [4] Carnicer, M. M.: [The Poincaré problem in the nondicritical case](#). *Ann. of Math. (2)* **140** (1994), no. 2, 289–294.
- [5] Cavalier, V. and Lehmann, D.: [On the Poincaré inequality for one-dimensional foliations](#). *Compos. Math.* **142** (2006), no. 2, 529–540.
- [6] Cerveau, D. and Lins Neto, A.: [Holomorphic foliations in \$\mathbb{C}\mathbb{P}\(2\)\$ having an invariant algebraic curve](#). *Ann. Inst. Fourier (Grenoble)* **41** (1991), no. 4, 883–903.
- [7] Corral, N. and Fernández-Sánchez, P.: [Isolated invariant curves of a foliation](#). *Proc. Amer. Math. Soc.* **134** (2006), no. 4, 1125–1132.
- [8] Galindo, C. and Monserrat, F.: [The Poincaré problem, algebraic integrability and dicritical divisors](#). *J. Differential Equations* **256** (2014), no. 11, 3614–3633.
- [9] Genzmer, Y. and Mol, R.: [Local polar invariants and the Poincaré problem in the dicritical case](#). *J. Math. Soc. Japan* **70** (2018), no. 4, 1419–1451.
- [10] Gómez-Mont, X., Seade, J. and Verjovsky, A.: [The index of a holomorphic flow with an isolated singularity](#). *Math. Ann.* **291** (1991), no. 4, 737–751.
- [11] Hertling, C.: [Formules pour la multiplicité et le nombre de Milnor d’un feuilletage sur \$\(\mathbb{C}^2, 0\)\$](#) . *Ann. Fac. Sci. Toulouse Math. (6)* **9** (2000), no. 4, 655–670.
- [12] Ilyashenko, Y. and Yakovenko, S.: [Lectures on analytic differential equations](#). Graduate Studies in Mathematics 86, American Mathematical Society, Providence, RI, 2008.
- [13] Lins Neto, A.: [Construction of singular holomorphic vector fields and foliations in dimension two](#). *J. Differential Geom.* **26** (1987), no. 1, 1–31.
- [14] Lins Neto, A.: [Some examples for the Poincaré and Painlevé problems](#). *Ann. Sci. École Norm. Sup. (4)* **35** (2002), no. 2, 231–266.
- [15] Pereira, J. V.: [On the Poincaré problem for foliations of general type](#). *Math. Ann.* **323** (2002), no. 2, 217–226.

Received June 16, 2022; revised October 16, 2023. Published online November 11, 2023.

Pedro Fortuny Ayuso

Departamento de Matemáticas, Facultad de Ciencias, Universidad de Oviedo,
C/ Leopoldo Calvo Sotelo 18, 33007 Oviedo, Spain;
fortunypedro@uniovi.es

Javier Ribón

Instituto de Matemática e Estatística, Universidade Federal Fluminense,
Bloco G, Campus do Gragoatá, São Domingos, 24210-201, Niterói, RJ, Brazil;
jribon@id.uff.br