

Curvature integrals on the real Milnor fibre

Nicolas Dutertre

Abstract. Let $f: \mathbb{R}^{n+1} \rightarrow \mathbb{R}$ be a polynomial with an isolated critical point at 0 and let $f_t: \mathbb{R}^{n+1} \rightarrow \mathbb{R}$ be a one-parameter deformation of f . We study the differential geometry of the real Milnor fibre $C_t^\varepsilon = f_t^{-1}(0) \cap B_\varepsilon^{n+1}$. More precisely, we express the limits

$$\lim_{\varepsilon \rightarrow 0} \lim_{t \rightarrow 0} \frac{1}{\varepsilon^k} \int_{C_t^\varepsilon} s_{n-k}(x) \, dx,$$

where s_{n-k} is the $(n-k)$ -th symmetric function of curvature, in terms of the following averages of topological degrees:

$$\int_{G_{n+1}^k} \deg_0 \nabla(f|_H) \, dH,$$

where G_{n+1}^k is the Grassmann manifold of k -dimensional planes through the origin of \mathbb{R}^{n+1} .

When 0 is an algebraically isolated critical point, we study the limits

$$\lim_{\varepsilon \rightarrow 0} \lim_{t \rightarrow 0} \frac{1}{\varepsilon^k} \int_{C_t^\varepsilon} h_{n-k}(x) \, dx,$$

where the h_{n-k} are positive extrinsic curvature functions. We prove that these limits are finite and that they are bounded in terms of the Milnor–Teissier numbers of the complexification of f .

Mathematics Subject Classification (2000). 14P25, 58K15, 53C65.

Keywords. Real Milnor fibre, curvatures, topological degree.

1. Introduction

Let $f: \mathbb{C}^{n+1} \rightarrow \mathbb{C}$ be a polynomial such that $f(0) = 0$ and 0 is an isolated singularity in $f^{-1}(0)$. Let $C_\lambda^\varepsilon = f^{-1}(\lambda) \cap B_\varepsilon^{2n+2}$ be the Milnor fibre of this singularity. It can be viewed as a $2n$ -dimensional manifold with boundary in \mathbb{R}^{2n+2} and therefore, with each point of its interior, we can associate a curvature, namely the Lipschitz–Killing curvature introduced by Fenchel in [Fe]. Let us recall what this curvature is. Given a point x belonging to a smooth p -dimensional manifold V in \mathbb{R}^N and a unit normal vector v to V at x , we will denote by π_v the orthogonal projection from V to the $(p+1)$ -dimensional vector space spanned by $T_x V$ and v . The image of this projection is a

hypersurface non-singular at x , we denote by $K(x, \pi_v(V))$ its Gaussian curvature at x . The Lipschitz–Killing curvature at x is

$$LK(x) = c(N, p) \int_{NU_x V} K(x, \pi_v(V)) dv,$$

where $NU_x V$ is the unitary normal space of V at x and where $c(N, p)$ depends only on N and p . When V is an open bounded subset of a complex hypersurface in \mathbb{C}^{n+1} , Langevin [La1], [La3] gave a nice way to compute $\int_V LK(x) dx$ using Morse theory and orthogonal projections on complex lines. More precisely, for almost all complex lines $L \subset \mathbb{C}\mathbb{P}^n$, the restriction to V of the orthogonal projection on L admits only non-degenerate critical points. Denoting by $|\mu(V, L)|$ the number of these critical points, we have the following equality, called the exchange formula:

$$\int_V (-1)^n LK(x) dx = c(n) \int_{\mathbb{C}\mathbb{P}^n} |\mu(V, L)| dL,$$

where $c(n)$ depends only on n . Such a result is interesting because it provides a link between the differential geometry and the intersection theory.

Applying this principle to the Milnor fibre, Langevin [La1] obtained

$$\int_{C_\lambda^\varepsilon} (-1)^n LK(x) dx = c(n) \int_{\mathbb{C}\mathbb{P}^n} |\mu(C_\lambda^\varepsilon, L)| dL.$$

A lemma due to Teissier [Te2] asserts that, as ε and λ tend to 0, the number $|\mu(C_\lambda^\varepsilon, L)|$ tends to $\mu^{(n+1)} + \mu^{(n)}$, where $\mu^{(n+1)}$ is the Milnor number of f at 0 and $\mu^{(n)}$ the first Milnor–Teissier number, namely the Milnor number of f restricted to a generic hyperplane section at 0. These last two numbers are integers. Furthermore $\mu^{(n+1)}$ depends only on the topological type of the germ of $f^{-1}(0)$ at the origin. Combining these two results, Langevin [La1] proved that

$$\lim_{\varepsilon \rightarrow 0} \lim_{\lambda \rightarrow 0} \int_{C_\lambda^\varepsilon} (-1)^n LK(x) dx = \frac{1}{2} \text{vol}(S^{2n}) (\mu^{(n+1)} + \mu^{(n)}).$$

Thus Langevin’s formula states that the asymptotic behaviour of the Lipschitz–Killing curvature of C_λ^ε , more precisely the “amount” of curvature that concentrates around the singularity, is described in terms of analytic invariants of this singularity.

Similar formulas for the other symmetric functions of curvature were announced by Griffiths [Gr] and proved by Loeser [Lo], who showed

$$\lim_{\varepsilon \rightarrow 0} \lim_{\lambda \rightarrow 0} \frac{(-1)^{n-k} c(n, k)}{\varepsilon^{2k}} \int_{C_\lambda^\varepsilon} c_{n-k}(\Omega_{C_\lambda}) \wedge \phi^k = \mu^{(n-k+1)} + \mu^{(n-k)}, \quad k \in \{1, \dots, n\},$$

where $c_{n-k}(\Omega_{C_\lambda})$ is the $(n-k)$ -th Chern form on $C_\lambda = f^{-1}(\lambda)$, ϕ is the Kähler form on \mathbb{C}^{n+1} , $c(n, k)$ is an universal constant depending only on n and k and $\mu^{(n+1-k)}$

denotes the k -th Milnor–Teissier number [Te1]. This last number is the Milnor number of f restricted to a generic plane of codimension k . One should mention that Loeser’s paper concerns a more general situation from which the above formulas are special cases.

Adding up these equalities with alternating signs simplifies, and we get

$$1 + (-1)^n \mu^{(n+1)} = \sum_{k=0}^n \lim_{\varepsilon \rightarrow 0} \lim_{\lambda \rightarrow 0} \frac{c(n, k)}{\varepsilon^{2k}} \int_{C_\lambda^\varepsilon} c_{n-k}(\Omega_{C_\lambda}) \wedge \phi^k,$$

and we recover Kennedy’s formula [Ke] for the Euler characteristic of the Milnor fibre:

$$\chi(C_\lambda^\varepsilon) = \sum_{k=0}^n \lim_{\varepsilon \rightarrow 0} \lim_{\lambda \rightarrow 0} \frac{c(n, k)}{\varepsilon^{2k}} \int_{C_\lambda^\varepsilon} c_{n-k}(\Omega_{C_\lambda}) \wedge \phi^k.$$

All these results concern curvatures of the complex Milnor fibre. Let us focus now on the real situation whose study was initiated by Risler [Ri] and the author [Du2].

Let $f : \mathbb{R}^{n+1} \rightarrow \mathbb{R}$ be a polynomial such that $f(0) = 0$ and 0 is an isolated critical point of f . Let $f_t : \mathbb{R}^{n+1} \rightarrow \mathbb{R}$ be a one-parameter deformation of f such that $f_t^{-1}(0)$ is smooth near 0 for t small. The real Milnor fibre C_t^ε is $f_t^{-1}(0) \cap B_\varepsilon^{n+1}$, where $|t|$ is much smaller than ε in such a way that $f_t^{-1}(0)$ is transverse to $\partial B_\varepsilon^{n+1} = S_\varepsilon^n$. This definition is different from the complex one. Actually, we could have defined the complex Milnor fibre as the set $f_t^{-1}(0) \cap B_\varepsilon^{2n+2}$, $|t| \ll \varepsilon$. However, this is not usual because this set has the same homotopy type as C_λ^ε , namely the homotopy type of a wedge of $\mu^{(n+1)}$ spheres S^n , and complex geometers only consider deformations given by $f = \lambda$. In the real case, the topology of C_t^ε does depend on the deformation, which explains our definition of the real Milnor fibre.

Risler proved that $\lim_{\varepsilon \rightarrow 0} \lim_{t \rightarrow 0} \int_{C_t^\varepsilon} |K(x)| dx$ (where K is the curvature, i.e. the Jacobian determinant of the Gauss map) was finite and that it was bounded from above by

$$\frac{\text{vol}(S^n)}{\text{vol}(S^{2n})} \lim_{\varepsilon \rightarrow 0} \lim_{t \rightarrow 0} \int_{f_t^{-1}(0) \cap B^{2n+2}} |LK(x)| dx = \frac{1}{2} \text{vol}(S^n) (\mu^{(n+1)}(f_{\mathbb{C}}) + \mu^{(n)}(f_{\mathbb{C}})),$$

where $f_{\mathbb{C}}$ (resp. $f_{t, \mathbb{C}}$) is the complexification of f (resp. f_t).

In [Du2], we studied $\lim_{\varepsilon \rightarrow 0} \lim_{t \rightarrow 0} \int_{C_t^\varepsilon} K dv_t$ for a deformation f_t given by $f_t(x) = F(t, x)$, where (t, x) is a coordinate system for \mathbb{R}^{n+2} and $F : \mathbb{R}^{n+2} \rightarrow \mathbb{R}$ is a polynomial such that for all $x \in \mathbb{R}^{n+1}$, $f(x) = F(0, x)$. We assumed that the mapping $\bar{H} : \mathbb{R}^{n+2} \rightarrow \mathbb{R}^{n+2}$ defined by $\bar{H} = (F, \frac{\partial F}{\partial x_1}, \dots, \frac{\partial F}{\partial x_{n+1}})$ had an isolated zero at the origin. This implies that ∇F , the gradient vector of F , has an isolated zero at the origin as well. For $t \neq 0$, the set $f_t^{-1}(0)$ is smooth in a neighborhood of 0 (see [Du2], Lemma 3.1) and the real Milnor fibre C_t^ε is a smooth manifold with boundary

(possibly empty). Orientating it by ∇f_t , we proved a real version of Langevin’s formula ([Du2], Theorem 5.3):

$$\lim_{\varepsilon \rightarrow 0} \lim_{t \rightarrow 0^+} \int_{C_t^\varepsilon} K(x) dx = -\frac{1}{2} \text{vol}(S^n) [\text{deg}_0 \nabla F + \text{deg}_0 \bar{H}] + \frac{1}{2} \int_{G_{n+1}^n} \text{deg}_0 \nabla(f|_H) dH,$$

$$\lim_{\varepsilon \rightarrow 0} \lim_{t \rightarrow 0^-} \int_{C_t^\varepsilon} K(x) dx = -\frac{1}{2} \text{vol}(S^n) [\text{deg}_0 \nabla F - \text{deg}_0 \bar{H}] + \frac{1}{2} \int_{G_{n+1}^n} \text{deg}_0 \nabla(f|_H) dH.$$

Here G_{n+1}^n denotes the Grassmann manifold of n -dimensional vector spaces in \mathbb{R}^{n+1} and $\text{deg}_0 \bar{H}$ (resp. $\text{deg}_0 \nabla F$, $\text{deg}_0(f|_H)$) is the topological degree of $\frac{\bar{H}}{\|\bar{H}\|}$ around a small sphere (resp. $\frac{\nabla F}{\|\nabla F\|}$, $\frac{\nabla(f|_H)}{\|\nabla(f|_H)\|}$).

In that paper, we adapted to the real case the method developed by Langevin. We needed the following real version of the exchange theorem. If V is an open bounded subset of a smooth oriented hypersurface in \mathbb{R}^n then, for almost all lines $L \subset \mathbb{R}P^n$, the restriction to V of the orthogonal projection on L admits only non-degenerate critical points. To each of these points one can assign an index, the local topological degree of the Gauss mapping at the point. Let $\mu(V, L)$ be the sum of all these indices. We have (see [La3], [LS])

$$\int_V K(x) dx = \int_{\mathbb{R}P^n} \mu(V, L) dL.$$

Applied to C_t^ε , this formula gives

$$\int_{C_t^\varepsilon} K(x) dx = \int_{\mathbb{R}P^n} \mu(C_t^\varepsilon, L) dL.$$

Then we showed that, as ε and t tend to zero, $\mu(C_t^\varepsilon, L)$ tends to $-\text{deg}_0 \nabla F \pm \text{deg}_0 \bar{H} + \text{deg}_0 \nabla(f|_{L^\perp})$, where L^\perp is the orthogonal of L . Note that unlike the complex case this last term does depend on L .

The purpose of this paper is to give real versions of the Griffiths–Loeser formulas and of Kennedy’s formula. We will use the following notations:

- for $k \in \{0, \dots, n\}$, G_{n+1}^k is the Grassmann manifold of k -dimensional linear subspaces in \mathbb{R}^{n+1} and $g_{n+1,k}$ is its volume,
- for $k \in \{0, \dots, n\}$, s_k is the k -th symmetric function of curvature,
- for $k \in \mathbb{N}$, b_k is the volume of the k -dimensional unit ball and o_k is the volume of the k -dimensional unit sphere.

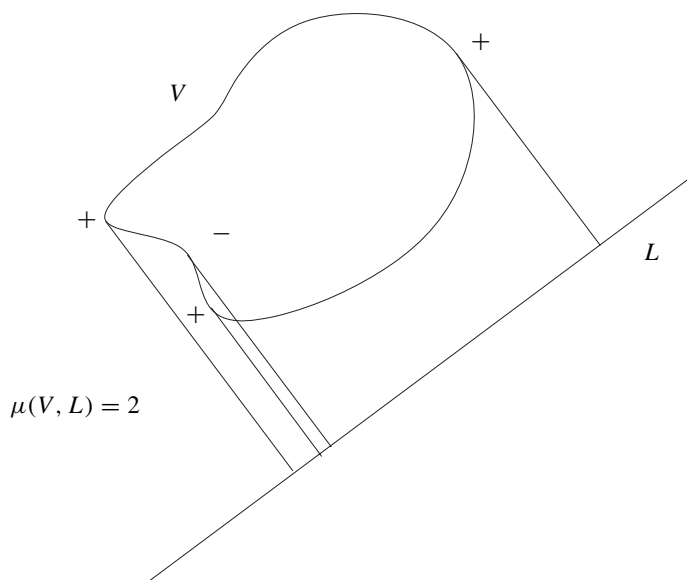

Figure 1. The exchange principle.

With the same assumptions as in the previous paragraph, we shall prove that (Theorem 7.1): for $k \in \{1, \dots, n - 1\}$,

$$\begin{aligned} & \frac{o_k}{\binom{n}{k} o_n} \lim_{\varepsilon \rightarrow 0} \lim_{t \rightarrow 0} \frac{1}{b_k \varepsilon^k} \int_{C_t^\varepsilon} s_{n-k}(x) dx \\ &= -\frac{1}{g_{n+1, n-k+2}} \int_{G_{n+1}^{n-k+2}} \text{deg}_0 \nabla(f|_K) dK + \frac{1}{g_{n+1, n-k}} \int_{G_{n+1}^{n-k}} \text{deg}_0 \nabla(f|_H) dH. \end{aligned}$$

Furthermore,

$$\lim_{\varepsilon \rightarrow 0} \lim_{t \rightarrow 0} \frac{1}{b_n \varepsilon^n} \int_{C_t^\varepsilon} s_0(x) dx = -\frac{1}{g_{n+1, 2}} \int_{G_{n+1}^2} \text{deg}_0 \nabla(f|_K) dK + 1.$$

From this and degree formulas for $\chi(C_t^\varepsilon)$ due to Fukui [Fu], we will deduce the following Gauss–Bonnet formula for the real Milnor fibre (Corollary 7.2): if n is even,

$$\chi(C_t^\varepsilon) = \sum_{k=0}^{n/2} \frac{o_{2k}}{\binom{n}{2k} o_n} \lim_{\varepsilon \rightarrow 0} \lim_{t \rightarrow 0} \frac{1}{b_{2k} \varepsilon^{2k}} \int_{C_t^\varepsilon} s_{n-2k}(x) dx,$$

and if n is odd,

$$\chi(C_t^\varepsilon) = \sum_{k=0}^{\frac{n-1}{2}} \frac{o_{2k+1}}{\binom{n}{2k+1} o_n} \lim_{\varepsilon \rightarrow 0} \lim_{t \rightarrow 0} \frac{1}{b_{2k+1} \varepsilon^{2k+1}} \int_{C_t^\varepsilon} s_{n-2k-1}(x) dx.$$

In the complex case, all the curvatures involved have a constant sign, whereas in the real case the sign of the symmetric functions of curvature may vary. However, Langevin and Shifrin [LS] defined, for a hypersurface $V \subset \mathbb{R}^{n+1}$, a sequence of positive curvatures h_0, \dots, h_n such that $h_0(x) = 1$ and $h_n(x) = |K(x)|$ for all $x \in V$. Moreover they proved that these curvatures satisfied the same reproducibility formulas as the s_i 's. We will work with them in order to get generalizations of Risler's inequality. More precisely, adding the assumption that f admits an algebraically isolated critical point at the origin, we shall show that (Theorem 7.1): for $k \in \{1, \dots, n - 1\}$,

$$\frac{o_k}{\binom{n}{k} o_n} \lim_{\varepsilon \rightarrow 0} \lim_{t \rightarrow 0} \frac{1}{b_k \varepsilon^k} \int_{C_t^\varepsilon} h_{n-k}(x) dx \leq \mu^{(n-k+1)}(f_{\mathbb{C}}) + \mu^{(n-k)}(f_{\mathbb{C}}).$$

Furthermore,

$$\lim_{\varepsilon \rightarrow 0} \lim_{t \rightarrow 0} \frac{1}{b_n \varepsilon^n} \int_{C_t^\varepsilon} h_0(x) dx \leq \mu^{(1)}(f_{\mathbb{C}}) + \mu^{(0)}(f_{\mathbb{C}}).$$

In order to establish our results, we use a method for the computation of $\int_V s_{n-k}(x) dx$ and $\int_V h_{n-k}(x) dx$, where V is a smooth bounded hypersurface in \mathbb{R}^{n+1} , due to Langevin and Shifrin [LS]. Let us explain briefly this method. The main idea is to refine the exchange principle by studying generic projections on higher dimensional vector spaces. Let $P \in G_{n+1}^{k+1}$, $0 \leq k \leq n - 1$ and let $\pi_P : V \rightarrow P$ be the restriction of the orthogonal projection on P . Generically the set Γ_P of critical values of π_P is almost everywhere a k -dimensional manifold. With each regular point y in Γ_P , we can associate two ‘‘curvature’’ indices $\lambda(y) \in \mathbb{Z}$ and $\mu(y) \in \mathbb{N}$. The integrals $\int_V s_{n-k}(x) dx$ and $\int_V h_{n-k}(x) dx$ are related to these indices as follows:

$$\int_V s_{n-k}(x) dx = c(n, k) \int_{G_{n+1}^{k+1}} \left(\int_{\Gamma_P} \lambda(y) dy \right) dP,$$

$$\int_V h_{n-k}(x) dx = c(n, k) \int_{G_{n+1}^{k+1}} \left(\int_{\Gamma_P} \mu(y) dy \right) dP.$$

Our strategy is to apply Langevin and Shifrin's machinery to the variety $C_0 = f^{-1}(0)$. Since f is algebraic, Γ_P is a semi-algebraic set of dimension k (or empty) in the neighborhood of 0. There exists a semi-algebraic set $W_P \subset \Gamma_P$ of dimension less than k such that the indices $\lambda(y)$ and $\mu(y)$ are constant on each connected component of $\Gamma_P \setminus W_P$. Writing $\Gamma_P \setminus W_P = \sqcup X_j^P$ and denoting by λ_j^P and μ_j^P the common values of $\lambda(y)$ and $\mu(y)$ on each X_j^P , we get

$$\frac{1}{b_k \varepsilon^k} \int_{C_0^\varepsilon \setminus \{0\}} s_{n-k}(x) dx = c(n, k) \int_{G_{n+1}^{k+1}} \sum_j \lambda_j^P \cdot \frac{\text{vol}(X_j^P \cap B_\varepsilon^P)}{b_k \varepsilon^k} dP,$$

$$\frac{1}{b_k \varepsilon^k} \int_{C_0^\varepsilon \setminus \{0\}} h_{n-k}(x) dx = c(n, k) \int_{G_{n+1}^{k+1}} \sum_j \mu_j^P \cdot \frac{\text{vol}(X_j^P \cap B_\varepsilon^P)}{b_k \varepsilon^k} dP,$$

where B_ε^P is the ball of radius ε in P . Applying Fubini’s theorem leads to

$$\begin{aligned} \lim_{\varepsilon \rightarrow 0} \frac{1}{b_k \varepsilon^k} \int_{C_0^\varepsilon \setminus \{0\}} s_{n-k}(x) dx &= c(n, k) \int_{G_{n+1}^{k+1}} \sum_j \lambda_j^P \cdot \Theta_k(X_j^P, 0) dP, \\ \lim_{\varepsilon \rightarrow 0} \frac{1}{b_k \varepsilon^k} \int_{C_0^\varepsilon \setminus \{0\}} h_{n-k}(x) dx &= c(n, k) \int_{G_{n+1}^{k+1}} \sum_j \mu_j^P \cdot \Theta_k(X_j^P, 0) dP. \end{aligned}$$

We recall that $\Theta_k(X_j^P, 0)$ is the density of X_j^P , which does exist for X_j^P is semi-algebraic (see [KR]). The remainder of the method is technical and difficult to present briefly. We use the Cauchy–Crofton formula for the density due to Comte [Co], the fact that the λ_j^P ’s are related to Morse critical points of some projections and some identifications between flag varieties in order to express $\int_{G_{n+1}^{k+1}} \sum_j \lambda_j^P \cdot \Theta_k(X_j^P, 0) dP$ in terms of mean-values of Euler characteristics of affine sections of C_0^ε . Using degree formulas for Euler characteristics, these last mean-values are easily seen to be mean-values of topological degrees.

The method for h_{n-k} is roughly the same; instead of degree formulas for Euler characteristics, we use Teissier’s lemma [Te2] which enables us to bound generically a number of critical points in terms of the Milnor–Teissier numbers.

The last step is to prove that

$$\begin{aligned} \lim_{\varepsilon \rightarrow 0} \lim_{t \rightarrow 0} \frac{1}{\varepsilon^k} \int_{C_t^\varepsilon} s_{n-k}(x) dx &= \lim_{\varepsilon \rightarrow 0} \frac{1}{\varepsilon^k} \int_{C_0^\varepsilon \setminus \{0\}} s_{n-k}(x) dx, \\ \lim_{\varepsilon \rightarrow 0} \lim_{t \rightarrow 0} \frac{1}{\varepsilon^k} \int_{C_t^\varepsilon} h_{n-k}(x) dx &= \lim_{\varepsilon \rightarrow 0} \frac{1}{\varepsilon^k} \int_{C_0^\varepsilon \setminus \{0\}} h_{n-k}(x) dx. \end{aligned}$$

Throughout the paper, we will use the following notations and conventions (some of them have already appeared in this introduction):

- o_k is the volume of S^k , b_k is the volume of the unit ball in \mathbb{R}^k .
- G_{n+1}^k is the Grassmann manifold of k -dimensional linear spaces in \mathbb{R}^{n+1} , $g_{n+1,k}$ is its volume (see [Sa] for an explicit expression of $g_{n+1,k}$).
- A_{n+1}^k is the affine grassmannian of k -dimensional affine spaces in \mathbb{R}^{n+1} .
- If H is a linear subspace of \mathbb{R}^{n+1} , G_H^k is the Grassmann manifold of k -dimensional linear spaces in H , H^\perp is its orthogonal, B_ε^H is the ball of radius ε centered at 0 in H . If $K \subset H$ is a linear subspace of H , K^\perp is the orthogonal of K in H .

- If v_1, \dots, v_q are vectors in \mathbb{R}^{n+1} , $\text{Span}(v_1, \dots, v_q)$ is the linear space spanned by v_1, \dots, v_q .
- If $X \subset \mathbb{R}^{n+1}$, $\text{Sing}(X)$ is the singular set of X , \bar{X} is its topological closure, $\overset{\circ}{X}$ is its interior and $\text{Bd}(X)$ is its boundary.
- If $M \subset \mathbb{R}^{n+1}$ is a submanifold, $\text{Fra}(M)$ is the set of adapted frames for M .
- A universal constant that we do not want to specify will be denoted by “cst”.
- We will often say orthogonal projection for the restriction of an orthogonal projection to a submanifold in \mathbb{R}^{n+1} .

The paper is organized as follows: in Section 2, we present the background in differential geometry necessary for our work. In Section 3, we study generic projections and polar varieties. In Section 4, we give the relations between topological degrees and Euler characteristics. Section 5 is devoted to the proof of the formulas dealing with $\lim_{\varepsilon \rightarrow 0} \frac{1}{b_k \varepsilon^k} \int_{C_0^\varepsilon \setminus \{0\}} s_{n-k}(x) dx$ and $\lim_{\varepsilon \rightarrow 0} \frac{1}{b_k \varepsilon^k} \int_{C_0^\varepsilon \setminus \{0\}} h_{n-k}(x) dx$. Section 6 relates $\lim_{\varepsilon \rightarrow 0} \lim_{t \rightarrow 0} \frac{1}{b_k \varepsilon^k} \int_{C_t^\varepsilon} s_{n-k}(x) dx$ and $\lim_{\varepsilon \rightarrow 0} \lim_{t \rightarrow 0} \frac{1}{b_k \varepsilon^k} \int_{C_t^\varepsilon} h_{n-k}(x) dx$ to the previous limits. The real versions of the Griffiths–Loeser formulas and of Kennedy’s formula are given in Section 7.

Several authors have worked on this subject of curvatures and invariants of singularities. Besides the ones already stated in the introduction, one can also mention the following papers: [G-B.T], [La2], [LL], [ST], [Ne], [Va] in the complex case and [BB],[CGM], [Du3] in the real case.

The author is grateful to Georges Comte for valuable discussions on this topic and to David Trotman for his careful reading of this manuscript.

2. Differential geometric preliminaries

In this section, we recall differential geometric results obtained by Langevin and Shifrin [LS] (see also [LR]). We will restrict ourselves to the case of a smooth oriented hypersurface.

Let $V \subset \mathbb{R}^{n+1}$ be an oriented hypersurface of class C^2 . A moving frame on an open subset $U \subset V^n$ is a set of smooth mappings $e_i : U \rightarrow \mathbb{R}^{n+1}$ such that for each x in U , $e_1(x), \dots, e_n(x)$ form an orthonormal basis for $T_x V$ and $e_{n+1}(x)$ is the unit normal vector in $N_x V = (T_x V)^\perp$ orienting V . Let ω_i be the 1-form dual to e_i (note that $\omega_{n+1} = 0$) and let $\omega_{i,j}$ be defined by $de_i = \sum \omega_{i,j} e_j$, where de_i is seen as a \mathbb{R}^{n+1} -valued 1-form. We have $\omega_{i,j} = \langle de_i, e_j \rangle$, where $\langle \cdot, \cdot \rangle$ denotes the usual scalar product in \mathbb{R}^{n+1} (note that $\omega_{i,j} = -\omega_{j,i}$).

The (Gaussian) curvature K is the Jacobian determinant of the Gauss map $\gamma : V \rightarrow S^n$, $\gamma(x) = e_{n+1}(x)$. We can consider de_{n+1} as an endomorphism of $T_x V$ and we

have

$$KdV = K\omega_1 \wedge \cdots \wedge \omega_n = (de_{n+1})^*(\omega_1) \wedge \cdots \wedge (de_{n+1})^*(\omega_n),$$

where $(de_{n+1})^*: (T_x V)^* \rightarrow (T_x V)^*$ is the transpose map of de_{n+1} . Since $de_{n+1} = \sum_{i=1}^n \omega_{n+1,i} e_i$, we find that for $i \in \{1, \dots, n\}$, $(de_{n+1})^*(\omega_i) = \omega_i(de_{n+1}) = \omega_{n+1,i}$ and that

$$KdV = K\omega_1 \wedge \cdots \wedge \omega_n = \bigwedge_{i=1}^n \omega_{n+1,i} = (-1)^n \bigwedge_{i=1}^n \omega_{i,n+1}.$$

The endomorphism de_{n+1} of $T_x V$ is self-adjoint and its eigenvalues k_1, \dots, k_n are called the principal curvatures of V at x . The symmetric functions of curvature $s_0(x), \dots, s_n(x)$ are defined as the coefficients of the following polynomial:

$$\det(\text{Id} + tde_{n+1}(x)) = \prod_{i=1}^n (1 + k_i(x)t) = \sum_{i=0}^n s_i(x) \cdot t^i.$$

We note that s_n is the curvature K and that $s_0(x) = 1$. Langevin and Shifrin give a geometric interpretation of the other symmetric functions.

Let $x \in V$ and let $l \in G_{T_x V}^q$ be a q -plane ($q = 1, \dots, n$). Let L be the $(q + 1)$ -plane $l \oplus \gamma(x)$. Let (e_1, \dots, e_q) be a direct orthonormal basis of l , we orientate L choosing $(e_1, \dots, e_q, \gamma(x))$ as a direct orthonormal basis. The section $V \cap L$ can be viewed as a hypersurface in L . Let $K(x, l)$ be its curvature at x . Note that if we change the orientation of l , the orientation of L is reversed and so $K(x, l)$ does not change.

Proposition 2.1. *Let $x \in V$ and let $l \in G_{T_x V}^q$. We have*

$$s_q(x) = \binom{n}{q} \frac{1}{g_{n,q}} \int_{G_{T_x V}^q} K(x, l) dl.$$

Proof. The proof is given in [LS], p560. We repeat it here with more details. Let $e_1, \dots, e_q; e_{q+1}, \dots, e_n; e_{n+1}$ be an adapted frame for $V \cap L \subset V \subset \mathbb{R}^{n+1}$ (i.e. e_1, \dots, e_q are tangent to $V \cap L$ and e_1, \dots, e_n to V). Let us denote by E the tangent space $T_x V$ and by $A: E \rightarrow E$ the linear map $de_{n+1}: T_x V \rightarrow T_x V$. The q -vectors $e_{i_1} \wedge \cdots \wedge e_{i_q}$, $1 \leq i_1 < \cdots < i_q \leq n$, form an orthonormal basis of the space $\wedge^q E$ and we have

$$\wedge^q A(e_1 \wedge \cdots \wedge e_q) = K(x, l)(e_1 \wedge \cdots \wedge e_q) + \sum_{i_1 \neq 1, \dots, i_q \neq q} \alpha_{i_1, \dots, i_q} e_{i_1} \wedge \cdots \wedge e_{i_q}.$$

Let (v_1, \dots, v_n) be an orthonormal basis of eigenvectors of A , each v_i being associated with the eigenvalue k_i . The q -vectors $v_{i_1} \wedge \cdots \wedge v_{i_q}$, $1 \leq i_1 < \cdots < i_q \leq n$, form

an orthonormal basis of eigenvectors of $\wedge^q A$, each $v_{i_1} \wedge \cdots \wedge v_{i_q}$ being associated with the eigenvalue $k_{i_1} \dots k_{i_q}$. Let $\langle \cdot, \cdot \rangle_q$ denote the usual scalar product in $\wedge^q E$. We have

$$\begin{aligned} & \wedge^q A(e_1 \wedge \cdots \wedge e_q) \\ &= \sum_{1 \leq i_1 < \cdots < i_q \leq n} \langle e_1 \wedge \cdots \wedge e_q, v_{i_1} \wedge \cdots \wedge v_{i_q} \rangle_q \wedge^q A(v_{i_1}, \dots, v_{i_q}), \\ &= \sum_{1 \leq i_1 < \cdots < i_q \leq n} \langle e_1 \wedge \cdots \wedge e_q, v_{i_1} \wedge \cdots \wedge v_{i_q} \rangle_q k_{i_1} \dots k_{i_q} v_{i_1} \wedge \cdots \wedge v_{i_q}, \end{aligned}$$

hence,

$$\begin{aligned} K(x, l) &= \sum_{1 \leq i_1 < \cdots < i_q \leq n} \langle e_1 \wedge \cdots \wedge e_q, v_{i_1} \wedge \cdots \wedge v_{i_q} \rangle_q^2 k_{i_1} \dots k_{i_q}, \\ &= \sum_{1 \leq i_1 < \cdots < i_q \leq n} (\det [\langle e_i, v_{i_j} \rangle]_{1 \leq i, j \leq q})^2 k_{i_1} \dots k_{i_q}. \end{aligned}$$

We can write

$$\int_{G_{T_x V}^q} K(x, l) dl = \sum_{1 \leq i_1 < \cdots < i_q \leq n} \left(\int_{G_{T_x V}^q} I(l, v_{i_1} \wedge \dots \wedge v_{i_q}) dl \right) \cdot k_{i_1} \dots k_{i_q},$$

where $I(l, v_{i_1} \wedge \cdots \wedge v_{i_q}) = (\det [\langle e_i, v_{i_j} \rangle]_{1 \leq i, j \leq q})^2$ does not depend on the choice of the direct orthonormal basis (e_1, \dots, e_q) of l . Since $G_{T_x V}^q$ is $\text{SO}(T_x V)$ -invariant, the integral

$$\int_{G_{T_x V}^q} I(l, v_{i_1} \wedge \dots \wedge v_{i_q}) dl$$

does not depend on the q -vector $v_{i_1} \wedge \cdots \wedge v_{i_q}$. This gives the result, the multiplicative constant being computed by taking $V = S^n$. \square

By analogy, Langevin and Shifrin [LS] (see also [LR]) define other curvature functions h_0, \dots, h_n on V .

Definition 2.2. For $q = 0, \dots, n$ and for all $x \in V$,

$$h_q(x) = \binom{n}{q} \frac{1}{g_{n,q}} \int_{G_{T_x V}^q} |K(x, l)| dl.$$

Note that for all $x \in V$, $h_n(x) = |K(x)| = |s_n(x)|$ and $h_0(x) = 1$. In order to study the functions s_q and h_q , we need a general version of Meusnier's theorem about surfaces. Let $x \in V$ and let L be a $(q + 1)$ -affine plane ($q = 0, \dots, n$)

passing through x , $L \not\subset T_x V$, whose direction is the $(q + 1)$ -vector plane l . Let π_l be the orthogonal projection on l and let (e_1, \dots, e_q) be a direct orthonormal basis of $T_x(V \cap L)$. We orientate L in such a way that $(e_1, \dots, e_q, \pi_l(\gamma(x)))$ is a direct basis for l . The section $V \cap L$ is a hypersurface of L , we denote by $K(x, V \cap L)$ its curvature. It does not depend on the orientation chosen for $T_x(V \cap L)$.

Proposition 2.3.

$$K(x, T_x V \cap L) = \|\pi_l(\gamma(x))\|^q \cdot K(x, V \cap L).$$

(Here $T_x V \cap L$ is seen as a q -vector plane in $T_x V$ as in Proposition 2.1.)

Proof. The proof for $q = n - 1$ is given in [LS], p. 561. We prove the general case. Let $e'_1, \dots, e'_q; e'_{q+1}; e'_{q+2}, \dots, e'_{n+1}$ be an adapted frame for $V \cap L \subset L \subset \mathbb{R}^{n+1}$ ($e'_{q+2}, \dots, e'_{n+1}$ are normal to L) in a neighborhood of x . Furthermore we take $e'_{q+1} = \frac{\pi_l(\gamma)}{\|\pi_l(\gamma)\|}$. We have

$$K(x, V \cap L) \bigwedge_{\alpha=1}^q \omega'_\alpha = \bigwedge_{\alpha=1}^q \omega'_{q+1,\alpha}$$

since e'_{q+1} is normal to $V \cap L$ in L . Hence

$$K(x, V \cap L) = \bigwedge_{\alpha=1}^q \omega'_{q+1,\alpha}(x)(e'_1, \dots, e'_q).$$

Now let $e_1, \dots, e_q; e_{q+1}; e_{q+2}, \dots, e_{n+1}$ be an adapted frame for $V \cap (T_x V \cap L) \subset V \subset \mathbb{R}^{n+1}$ such that $e_\alpha = e'_\alpha$ at x for $1 \leq \alpha \leq q$. We have

$$K(x, T_x V \cap L) \bigwedge_{\alpha=1}^q \omega_\alpha = \bigwedge_{\alpha=1}^q \omega_{q+1,\alpha},$$

hence

$$K(x, T_x V \cap L) = \bigwedge_{\alpha=1}^q \omega_{q+1,\alpha}(x)(e'_1, \dots, e'_q).$$

For each $1 \leq \alpha \leq q$, $\omega_{n+1,\alpha}$ is equal to $\langle de_{n+1}, e'_\alpha \rangle$ at x . Since $\langle e_{n+1}, e'_\alpha \rangle = 0$, we obtain

$$\begin{aligned} \langle de_{n+1}, e'_\alpha \rangle &= -\langle de'_\alpha, e_{n+1} \rangle = -\left\langle de'_\alpha, \sum_{\beta=q+1}^{n+1} \langle e_{n+1}, e'_\beta \rangle e'_\beta \right\rangle \\ &= -\langle e_{n+1}, e'_{q+1} \rangle \omega'_{\alpha,q+1} = \langle e_{n+1}, e'_{q+1} \rangle \omega'_{q+1,\alpha}, \end{aligned}$$

because $\langle de'_\alpha, e'_\beta \rangle \equiv -\langle de'_\beta, e'_\alpha \rangle \equiv 0$ for $\beta \geq q + 2$, the vectors e'_β being constant. \square

We can state reproducibility formulas for the functions s_q and h_q .

Proposition 2.4. *Let $V \subset \mathbb{R}^{n+1}$ be a bounded hypersurface. Then:*

$$\int_V s_q(x) dx = \text{cst} \int_{A_{n+1}^{q+1}} \left(\int_{V \cap L} K(x, V \cap L) dx \right) dL,$$

$$\int_V h_q(x) dx = \text{cst} \int_{A_{n+1}^{q+1}} \left(\int_{V \cap L} |K(x, V \cap L)| dx \right) dL.$$

Proof. The case $q = n - 1$ is proved in [LS], p577. We adapt this proof to the general case. Consider the incidence relation

$$\{(x, L) \in V \times A_{n+1}^{q+1} \mid x \in L\}$$

and the bundle of adapted frames

$$\begin{aligned} & ((x, e'_1, \dots, e'_q; e'_{q+1}, \dots, e'_n; e'_{n+1}), (x, e_1, \dots, e_q; e_{q+1}, \dots, e_n; e_{n+1})) \\ & \in \text{Fra}(A_{n+1}^{q+1}) \times \text{Fra}(V), \end{aligned}$$

such that $e_1 = e'_1, \dots, e_q = e'_q$ is a frame for $V \cap L$.

We have to compute the density $dv_{V \cap L} \wedge dL$ where $dv_{V \cap L}$ is the volume element on $V \cap L$ and dL is the invariant measure on A_{n+1}^{q+1} . We have

$$dv_{V \cap L} = \wedge \omega_\alpha, \quad \alpha = 1, \dots, q,$$

and (see [Sa], p. 202)

$$dL = \bigwedge \omega'_i \wedge \bigwedge \omega'_{\beta,j} \wedge \bigwedge \omega'_{q+1,j}, \quad \beta = 1, \dots, q, \quad i, j = q+2, \dots, n+1.$$

But ω'_i is equal to $\sum_{k=q+1}^n \langle e'_i, e_k \rangle \omega_k$ (remember that $\omega_{n+1} = 0$), hence we get

$$dv_{V \cap L} \wedge dL = \left| \det [\langle e'_i, e_k \rangle]_{\substack{q+1 \leq k \leq n \\ q+2 \leq i \leq n+1}} \right| dv_V \wedge \bigwedge \omega'_{\beta,j} \wedge \bigwedge \omega'_{q+1,j}.$$

For each β , we have

$$\begin{aligned} \omega'_{\beta,j} &= \langle de'_\beta, e'_j \rangle = \left\langle de_\beta, \sum_{t=q+1}^{n+1} \langle e'_j, e_t \rangle e_t \right\rangle \\ &= \sum_{t=q+1}^{n+1} \langle e'_j, e_t \rangle \omega_{\beta,t} = \sum_{t=q+1}^n \langle e'_j, e_t \rangle \omega_{\beta,t} \text{ mod } (\omega_1, \dots, \omega_n). \end{aligned}$$

This implies that

$$dv_{V \cap L} \wedge dL = \left| \det [\langle e'_i, e_k \rangle]_{\substack{q+1 \leq k \leq n \\ q+2 \leq i \leq n+1}} \right| \times \left| \det [\langle e'_i, e_t \rangle]_{\substack{q+1 \leq t \leq n \\ q+2 \leq i \leq n+1}} \right|^q dv_V \wedge \bigwedge \omega_{\beta,t} \wedge \bigwedge \omega'_{q+1,j},$$

hence

$$dv_{V \cap L} \wedge dL = \left| \det [\langle e'_i, e_k \rangle]_{\substack{q+1 \leq k \leq n \\ q+2 \leq i \leq n+1}} \right|^{q+1} dv_V \wedge \bigwedge \omega_{\beta,t} \wedge \bigwedge \omega'_{q+1,j}.$$

By a result on orthogonal matrices, we get

$$dv_{V \cap L} \wedge dL = |\langle e'_{q+1}, e_{n+1} \rangle|^{q+1} dv_V \wedge \bigwedge \omega_{\beta,t} \wedge \bigwedge \omega'_{q+1,j}.$$

We see that $\bigwedge \omega_{\beta,t}, \beta = 1, \dots, q, t = q + 1, \dots, n$ is the measure dl of the space $G^q_{T_x V}$. Moreover, $\bigwedge \omega'_{q+1,j}, j = q + 2, \dots, n + 1$, is the measure dp of the space $G^1_{N_x(V \cap L)}$. Finally,

$$\begin{aligned} & \int_{A^{q+1}_{n+1}} \left(\int_{V \cap L} K(x, V \cap L) dx \right) dL \\ &= \int_V \int_{G^q_{T_x V}} \left(\int_{G^1_{N_x(V \cap L)}} |\langle e'_{q+1}, e_{n+1} \rangle| dp \right) |\langle e'_{q+1}, e_{n+1} \rangle|^q K(x, V \cap L) dL dx. \end{aligned}$$

From Proposition 2.3 we have $|\langle e'_{q+1}, e_{n+1} \rangle|^q K(x, V \cap L) = K(x, T_x V \cap L) = K(x, l)$ with $l = T_x V \cap L$. Furthermore, the integral

$$\int_{G^1_{N_x(V \cap L)}} |\langle e'_{q+1}, e_{n+1} \rangle| dp,$$

where e'_{q+1} is a unit vector of p , does not depend neither on $N_x(V \cap L)$ nor on e_{n+1} and is equal to

$$\int_{G^{1}_{n+1-q}} |\langle e(p), w \rangle| dp,$$

where w is a unit vector in \mathbb{R}^{n+1-q} and $e(p)$ an unit vector of p . This implies the result for K . The same argument holds for $|K|$. □

Langevin and Shifrin's idea is to relate $\int_V s_q(x) dx$ and $\int_V h_q(x) dx$ to polar varieties of generic projections and to generalize somehow the exchange formulas. First we recall some results on polar varieties. Let $P \in G^k_{n+1}, k = 1, \dots, n$, and let $\pi_P : V \rightarrow P$ be the orthogonal projection on P . We denote by Σ_P the set of critical points of π_P and $\Gamma_P = \pi_P(\Sigma_P)$ the set of critical values. Usually Σ_P is called a polar set or polar variety.

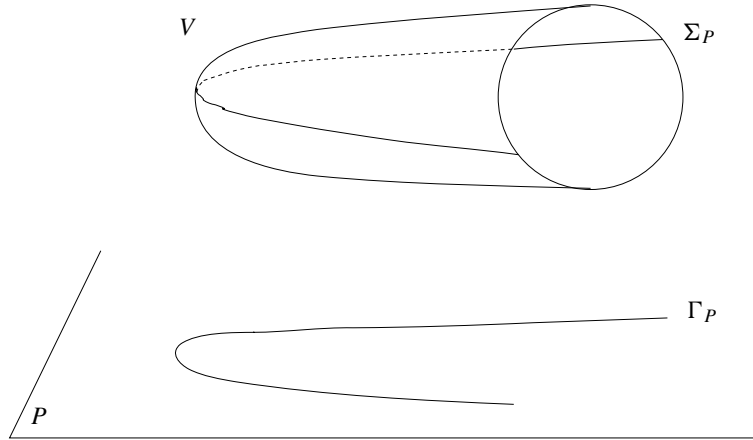

Figure 2. The sets Σ_P and Γ_P .

Lemma 2.5. *For almost all $P \in G_{n+1}^k$, Σ_P is a smooth $(k - 1)$ -dimensional submanifold of V (or is empty).*

Proof. We can refer to Mather’s work [Ma] on generic projections. Here we give an alternative proof due to Slavskii [SI]. We can assume that $V = \{x \in \mathbb{R}^{n+1} \mid f(x) = 0\}$ where $f: \mathbb{R}^{n+1} \rightarrow \mathbb{R}$ is C^2 and ∇f does not vanish on V . Let us put $q = n + 1 - k$ and let us consider

$$F: \mathbb{R}^{n+1} \times (\mathbb{R}^{n+1})^q \rightarrow \mathbb{R}^{q+1},$$

$$(x, v_1, \dots, v_q) \mapsto (f, \langle \nabla f, v_1 \rangle, \dots, \langle \nabla f, v_q \rangle).$$

Since V is non-singular, it is easy to see that $dF(x, v_1, \dots, v_q)$ has rank $q + 1$ if $F(x, v_1, \dots, v_q) = 0$. The set $F^{-1}(0)$ is then a smooth manifold of dimension $n(q + 1)$. Let $\pi: \mathbb{R}^{n+1} \times (\mathbb{R}^{n+1})^q \rightarrow (\mathbb{R}^{n+1})^q$ be the projection $(x, v_1, \dots, v_q) \mapsto (v_1, \dots, v_q)$. Sard’s theorem implies that almost all (v_1, \dots, v_q) are regular values of $\pi|_{F^{-1}(0)}$, which means that $F^{-1}(0) \cap \pi^{-1}((v_1, \dots, v_q))$ is a smooth manifold of dimension $n - q = k - 1$ for almost all (v_1, \dots, v_q) . But $F^{-1}(0) \cap \pi^{-1}((v_1, \dots, v_q))$ is exactly Σ_P where $P = [\text{Span}(v_1, \dots, v_q)]^\perp$. \square

Lemma 2.6. *For almost all $P \in G_{n+1}^k$, the set*

$$\Sigma'_P = \{x \in \Sigma_P \mid \pi_P|_{\Sigma_P} \text{ is not regular at } x\}$$

is a union of submanifolds of Σ_P of codimension greater than or equal to 1 (when Σ_P is not empty).

Proof (due to Slavskii [Sl]). Let (v_1, \dots, v_q) be a regular value of the map $\pi|_{F^{-1}(0)}$ defined in the previous lemma and let P be $[\text{Span}(v_1, \dots, v_q)]^\perp$. We have

$$\Sigma'_P = \{x \in \mathbb{R}^{n+1} \mid f(x) = 0, \langle \nabla f(x), v_1 \rangle = \dots = \langle \nabla f(x), v_q \rangle = 0 \text{ and there is } w \in \text{Span}(v_1, \dots, v_q) \text{ such that } \langle \nabla \langle \nabla f(x), v_i \rangle, w \rangle = 0 \text{ for } i \in \{1, \dots, q\}\}.$$

The last condition is equivalent to

$$\det \left[\sum_{\alpha, \beta=1}^{n+1} \frac{\partial^2 f(x)}{\partial x_\alpha \partial x_\beta} v_i^\alpha v_j^\beta \right]_{1 \leq i, j \leq q} = 0 \quad \text{where } v_i = (v_i^1, \dots, v_i^{n+1}).$$

Let us call $\mathfrak{g}_q \simeq \mathbb{R}^{\frac{q^2+q}{2}}$ the space of symmetric $(q \times q)$ -matrices and let $\Omega_i \subset \mathbb{R}^{\frac{q^2+q}{2}}$ be the subset of matrices with corank $i, i = 1, \dots, q$. It is a submanifold of $\mathbb{R}^{\frac{q^2+q}{2}}$ of codimension $\frac{i^2+i}{2}$. Let Ω_0 be the set of matrices in \mathfrak{g}_q with determinant zero, Ω_0 is equal to $\bigcup_{i=1}^q \Omega_i$. We can write

$$\Sigma'_P = \{x \in \mathbb{R}^{n+1} \mid f(x) = 0, \langle \nabla f(x), v_1 \rangle = \dots = \langle \nabla f(x), v_q \rangle = 0, \left[\sum_{\alpha, \beta=1}^{n+1} \frac{\partial^2 f(x)}{\partial x_\alpha \partial x_\beta} v_i^\alpha v_j^\beta \right]_{1 \leq i, j \leq q} \in \Omega_0\}.$$

Let Σ_π be the critical set of $\pi|_{F^{-1}(0)}$ and let $\mathcal{U} = F^{-1}(0) \setminus \Sigma_\pi$. The mapping

$$\Phi: F^{-1}(0) \rightarrow \left[\sum_{\alpha, \beta=1}^{n+1} \frac{\partial^2 f(x)}{\partial x_\alpha \partial x_\beta} v_i^\alpha v_j^\beta \right]_{1 \leq i, j \leq q}$$

is regular on \mathcal{U} . This is due to the fact that on \mathcal{U} the vectors with $n + 1$ components u_1, \dots, u_q , defined by

$$u_i = \left(\sum_{\alpha=1}^{n+1} \frac{\partial^2 f}{\partial x_\alpha \partial x_1}(x) v_i^\alpha, \dots, \sum_{\alpha=1}^{n+1} \frac{\partial^2 f}{\partial x_\alpha \partial x_{n+1}}(x) v_i^\alpha \right),$$

are linearly independent. Locally the set $\tilde{\Omega}_0 = \Phi^{-1}(\Omega_0) \cap \mathcal{U}$ has the same structure as Ω_0 , that is for all $i \in \{0, \dots, q\}$, $\tilde{\Omega}_i = \Phi^{-1}(\Omega_i) \cap \mathcal{U}$ is a submanifold of \mathcal{U} of codimension $\frac{i^2+i}{2}$. Let $\tilde{\Omega}'_i \subset \tilde{\Omega}_i$ be the subset where $\pi|_{\tilde{\Omega}'_i}$ is not regular. From Sard's theorem, $\pi(\tilde{\Omega}'_i)$ has measure zero and then $\Delta = \pi(\Sigma_\pi) \cup \bigcup_{i=1}^q \pi(\tilde{\Omega}'_i)$ has measure zero. If $(v_1, \dots, v_q) \notin \Delta$ then $\pi^{-1}((v_1, \dots, v_q)) \cap \tilde{\Omega}_i$ is a submanifold of dimension $k - 1 - (\frac{i^2+i}{2})$. Since $\Sigma'_P = \pi^{-1}((v_1, \dots, v_q)) \cap \tilde{\Omega}_0$, the lemma is proved. \square

In the following preliminary results, we will assume that V is a smooth bounded semi-algebraic variety.

Lemma 2.7. *For almost all $P \in G_{n+1}^k$, Γ_P is a semi-algebraic set of dimension $k - 1$.*

Proof. The set Γ_P is semi-algebraic as the projection of the semi-algebraic set Σ_P . Moreover $\dim \Gamma_P \leq \dim \Sigma_P = k - 1$. Let x be a point in $\Sigma_P \setminus \Sigma'_P$. From the previous lemma, there exists a semi-algebraic neighborhood U_x of x , $U_x \subset \Sigma_P \setminus \Sigma'_P$, on which π_P is a diffeomorphism and then $\dim \pi_P(U_x) = k - 1$. But $\pi_P(U_x)$ is included in Γ_P hence $\dim \Gamma_P$ is greater than or equal to $k - 1$. \square

We define now an index associated with each point $x \in \Sigma_P \subset \Sigma'_P$. For this, we consider the normal section $V \cap (P^\perp \oplus \gamma(x))$ and the orthogonal projection $\pi_{\gamma(x)}^{P^\perp \oplus \gamma(x)}$ of this section on the line oriented by $\gamma(x)$.

Lemma 2.8. *The point x is a non-degenerate critical point of $\pi_{\gamma(x)}^{P^\perp \oplus \gamma(x)}$.*

Proof. It is clearly critical. We can assume that V is defined by $\{f = 0\}$ around x . Let us choose coordinates (x_1, \dots, x_n) around x such that $P^\perp = \{x_{q+1} = \dots = x_{n+1} = 0\}$ ($q = n + 1 - k$) and such that $\frac{\nabla f}{\|\nabla f\|}(x) = \nabla x_{n+1}(x)$. In that case, a local coordinates system at x for $V \cap (P^\perp \oplus \gamma(x))$ is given by (x_1, \dots, x_q) . The implicit function theorem together with some derivative computations shows that $\pi_{\gamma(x)}^{P^\perp \oplus \gamma(x)}$ is non-degenerate at x if and only if $\det \left[\frac{\partial^2 f}{\partial x_i \partial x_j}(x) \right]_{1 \leq i, j \leq q} \neq 0$. Writing $P^\perp = \text{Span}(v_1, \dots, v_q)$ where $\forall i \in \{1, \dots, q\}$, $v_i = \nabla x_i$ and keeping the notations of Lemma 2.6, we see that

$$\frac{\partial^2 f}{\partial x_i \partial x_j}(x) = \sum_{\alpha, \beta=1}^{n+1} \frac{\partial^2 f}{\partial x_\alpha \partial x_\beta}(x) v_i^\alpha v_j^\beta.$$

Since $x \notin \Sigma'_P$, we conclude that $\det \left[\frac{\partial^2 f}{\partial x_i \partial x_j}(x) \right]_{1 \leq i, j \leq q} \neq 0$. \square

We define $i_P(x)$ to be the number of positive eigenvalues of $\pi_{\gamma(x)}$.

Lemma 2.9. *We have $(-1)^{i_P(x)} = \text{sign } K(x, P^\perp)$.*

Proof. According to [Du2] Lemma 2.3, one has

$$\text{sign } K(x, P^\perp) = (-1)^q \cdot \text{sign} \left(\frac{\partial f}{\partial x_{n+1}}(x) \right)^q \cdot (-1)^{q - i_P(x)},$$

keeping the above coordinate system. But, in that system, $\frac{\partial f}{\partial x_{n+1}}(x)$ is equal to $\|\nabla f(x)\|$, which is strictly positive. \square

Following Langevin and Shifrin, we can define the q -length and the oriented q -length of V (this terminology appears in [LR]).

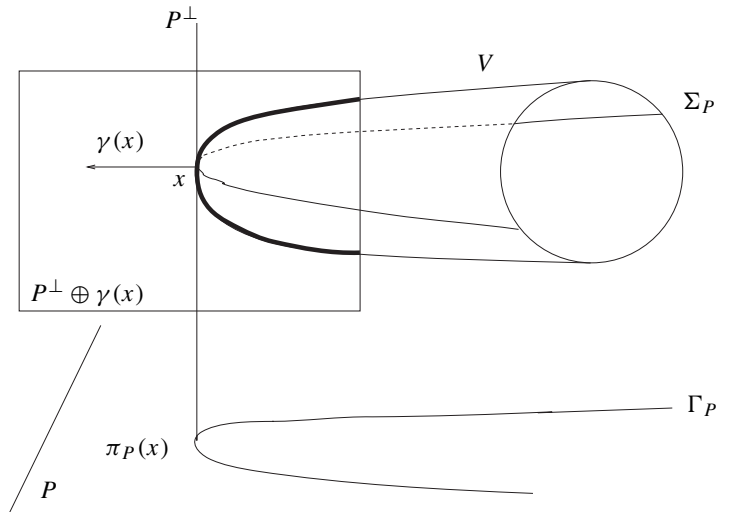

Figure 3. The index $i_P(x)$.

Definition 2.10. For each $q \in \{0, \dots, n - 1\}$, for almost all $P \in G_{n+1}^{q+1}$, we set

$$m^+(P) = \int_{\Gamma_P} \left(\sum_{\pi_P|_{\Sigma_P}(x)=y} (-1)^{i_P(x)} \right) dy$$

and

$$m(P) = \int_{\Gamma_P} \#(\pi_P|_{\Sigma_P})^{-1}(y) dy.$$

We define

$$L_q^+(V) = \frac{1}{g_{n+1,q+1}} \int_{G_{n+1}^{q+1}} m^+(P) dP,$$

and

$$L_q(V) = \frac{1}{g_{n+1,q+1}} \int_{G_{n+1}^{q+1}} m(P) dP.$$

Furthermore, we set $L_n^+(V) = L_n(V) = \text{vol}(V)$. We call $L_q^+(V)$ the oriented q -length of V and $L_q(V)$ the q -length of V .

First we note that $m^+(P)$ and $m(P)$ are well defined because $\dim \pi_P(\Sigma'_P) \leq n - 2$ and almost all y in Γ_P are regular values of $\pi_P|_{\Sigma_P}$. For such a y , $(\pi_P|_{\Sigma_P})^{-1}(y)$ is a 0-dimensional semi-algebraic set, hence a finite number of points. We also note that $L_0^+(V) = \int_V K(x) dx$ and $L_0(V) = \int_V |K(x)| dx$ by the exchange formula.

In order to relate the oriented q -length (resp. the q -length) to the curvature s_q (resp. h_q), we have to study the local situation at a point in $\Sigma_P \setminus \Sigma'_P$. Let us consider an $(n - q + 1)$ -affine plane L ($0 \leq q \leq n - 1$). Generically $V \cap L$ is a smooth $(n - q)$ -dimensional manifold. Let P be a $(q + 1)$ -vector plane containing the orthogonal of the direction of L . The intersection $l = P \cap L$ is an affine line in P . In L , let $\pi_l^L: V \cap L \rightarrow l$ be the orthogonal projection on l .

Lemma 2.11. *A point x in $(\Sigma_P \setminus \Sigma'_P) \cap L$ is a critical point of π_l^L .*

Proof. Let us assume that $V = \{f = 0\}$ near x . We can choose a coordinate system such that $P = \{x_{q+1} = \dots = x_{n+1} = 0\}$ and $L = \{x_1 = \alpha_1, \dots, x_q = \alpha_q\}$. In that case x is a critical point of π_P if and only if $\nabla f(x)$ is a linear combination of e_1, \dots, e_{q+1} ($e_i = \nabla x_i$). In L , x is a critical point of π_l^L if and only if e_{q+1} is a linear combination of e_1, \dots, e_q and $\nabla f(x)$. We conclude using the fact that $\nabla f(x)$ is not in the vector space spanned by e_1, \dots, e_q since V and L intersect transversally at x . \square

Lemma 2.12. *Such a point x is non-degenerate for π_l^L . Moreover,*

$$\text{sign } K(x, V \cap L) = (-1)^{i_P(x)}.$$

Proof. With the notations of the previous lemma, x is non-degenerate for π_l^L if and only if

$$\det \left[\frac{\partial^2 f(x)}{\partial x_i \partial x_j} \right]_{q+2 \leq i, j \leq n+1} \neq 0.$$

In the frame $(e_1, \dots, e_q, \frac{\nabla f}{\|\nabla f\|}(x), e_{q+2}, \dots, e_{n+1})$ with coordinate system

$$(x_1, \dots, x_q, x'_{q+1}, x_{q+2}, \dots, x_{n+1}),$$

P^\perp is the set $\{x_1 = 0, \dots, x_q = 0, x'_{q+1} = 0\}$ and $\frac{\nabla f}{\|\nabla f\|}(x)$ is equal to $\nabla x'_{q+1}(x)$, i.e. $\gamma(x)$. As in Lemma 2.8, we see that

$$\det \left[\frac{\partial^2 f(x)}{\partial x_i \partial x_j} \right]_{q+2 \leq i, j \leq n+1} \neq 0,$$

since $x \notin \Sigma'_P$. Finally, $(-1)^{i_P(x)} = \text{sign } K(x, P^\perp) = \text{sign } K(x, T_x V \cap L)$ for $P^\perp = T_x V \cap L$. We conclude with Proposition 2.3. \square

We need a last lemma which describes the structure of Γ_P .

Lemma 2.13. *There exists a semi-algebraic set $W_P \subset \overline{\Gamma_P}$ with $\dim W_P < k - 1$ such that the following functions in y ,*

$$\sum_{x \mid \pi_P|_{\Sigma_P}(x)=y} (-1)^{i_P(x)} \quad \text{and} \quad \sharp(\pi_P|_{\Sigma_P})^{-1}(y),$$

are defined and constant on each connected component of $\Gamma_P \setminus W_P$ and such that $\Gamma_P \setminus W_P$ is a smooth manifold of dimension $k - 1$.

Proof. Let

$$W_P = \overline{\text{Sing}(\Gamma_P) \cup \pi_P(\Sigma'_P) \cup \pi_P(\text{Bd}(\Sigma_P)) \cup \text{Bd}(\Gamma_P)}.$$

Since $\text{Sing}(\Gamma_P)$, $\pi_P(\Sigma'_P)$, $\pi_P(\text{Bd}(\Sigma_P))$ and $\text{Bd}(\Gamma_P)$ are semi-algebraic sets of dimension less than $k - 1$, $\dim W_P < k - 1$. Moreover, W_P is a closed set in P which contains $\text{Bd}(\Gamma_P)$, hence $\Gamma_P \setminus W_P$ is an open set in Γ_P included in $\overset{\circ}{\Gamma_P}$. The set $\Gamma_P \setminus W_P$ is a smooth $(k - 1)$ -dimensional manifold for $\text{Sing}(\Gamma_P) \subset W_P$ and the two functions are well-defined because $\pi_P(\Sigma'_P) \subset W_P$. Let y be a point $\Gamma_P \setminus W_P$ and let $\{x_1, \dots, x_{n_y}\}$ be $(\pi_P|_{\Sigma_P})^{-1}(y)$. For each $j \in \{1, \dots, n_y\}$, we can choose an open neighborhood $U_j \subset \Sigma_P$ such that $\pi_P|_{U_j}$ is a diffeomorphism and such that $(-1)^{i_P(x)} = (-1)^{i_P(x_j)}$ for each $x \in U_j$ (the function $K(x, P^\perp)$ is continuous in x). Let A be the following set:

$$A = \overline{\Sigma_P} \setminus \bigcup_{j=1}^{n_y} U_j.$$

It is a compact subset of $\overline{\Sigma_P}$, hence $\pi_P(A)$ is compact in $\overline{\Gamma_P}$. The point y does not belong to $\pi_P(A)$, for otherwise it would belong to $\pi_P(\text{Bd}(\Sigma_P))$. There exists an open neighborhood \mathcal{V} of y in $\overline{\Gamma_P}$ which does not intersect $\pi_P(A)$. Since y is an interior point of Γ_P , we can choose \mathcal{V} open in Γ_P . Then the two functions are constant on $\mathcal{V} \cap (\Gamma_P \setminus W_P)$. □

We can state now reproducibility formulas for the oriented q -length L_q^+ and the q -length L_q .

Proposition 2.14. *For $q \in \{0, \dots, n\}$ we have*

$$L_q^+(V) = \text{cst} \int_{A_{n+1}^{n+1-q}} L_0^+(V \cap L) dL,$$

and

$$L_q(V) = \text{cst} \int_{A_{n+1}^{n+1-q}} L_0(V \cap L) dL.$$

Proof. For $q = n$, this is just the Cauchy–Crofton formula because $L_0^+(V \cap L) = L_0(V \cap L) = \sharp\{V \cap L\}$. For $q \leq n - 1$, we have

$$L_q^+(V) = \frac{1}{g_{n+1, q+1}} \int_{G_{n+1}^{q+1}} \int_{\Gamma_P} \left(\sum_{x \mid \pi_P|_{\Sigma_P}(x)=y} (-1)^{i_P(x)} \right) dy dP.$$

But it is clear that

$$\int_{\Gamma_P} \left(\sum_{x \mid \pi_P|_{\Sigma_P}(x)=y} (-1)^{i_P(x)} \right) dy = \int_{\Gamma_P \setminus W_P} \left(\sum_{x \mid \pi_P|_{\Sigma_P}(x)=y} (-1)^{i_P(x)} \right) dy.$$

Let us decompose $\Gamma_P \setminus W_P$ into the finite union of its connected components, i.e., $\Gamma_P \setminus W_P = \bigcup X_j^P$. For each j , let us denote by λ_j^P the common value

$$\sum_{x \mid \pi_P|_{\Sigma_P}(x)=y} (-1)^{i_P(x)}.$$

We have

$$\int_{\Gamma_P} \left(\sum_{x \mid \pi_P|_{\Sigma_P}(x)=y} (-1)^{i_P(x)} \right) dy = \sum_j \lambda_j^P \cdot \text{vol}(X_j^P).$$

The Cauchy–Crofton formula in P gives

$$\text{vol}(X_j^P) = \text{cst} \int_{A_P^1} \sharp(X_j^P \cap l) dl,$$

and so

$$L_q^+(V) = \text{cst} \int_{G_{n+1}^{q+1}} \left(\int_{A_P^1} \sum_j \lambda_j^P \cdot \sharp(X_j^P \cap l) dl \right) dP.$$

Let y be a point in $X_j^P \cap l$. If $V \cap L$ is smooth, where L is the $(n - q + 1)$ -affine plane $P^\perp \oplus l$, then each preimage x of y by $\pi|_{\Sigma_P}$ is a non-degenerate critical point of the orthogonal projection $\pi_l^L: V \cap L \rightarrow l$, for $y \notin \pi_P(\Sigma'_P)$. Furthermore $(-1)^{i_P(x)} = \text{sign } K(x, V \cap L)$. Hence we get

$$\sum_j \lambda_j^P \cdot \sharp(X_j^P \cap l) = \sum_{\substack{x \mid x \text{ non degenerate} \\ \text{critical point of } \pi_l^L}} \text{sign } K(x, V \cap L).$$

Let \mathcal{F} be the flag variety of pairs (P, l) , $P \in G_{n+1}^{q+1}$ and $l \in A_P^1$. The mapping $(P, l) \mapsto (L, l)$ where $L = P^\perp \oplus l$ enables us to identify \mathcal{F} with the flag variety of pairs (L, l) , $L \in A_{n+1}^{n-q+1}$ and $l \in G_L^1$. Since for almost all $L \in A_{n+1}^{n-q+1}$, $V \cap L$ is smooth, we find

$$L_q^+(V) = \text{cst} \int_{A_{n+1}^{n-q+1}} \left[\int_{G_L^1} \left(\sum_{\substack{x \mid x \text{ non degenerate} \\ \text{critical point of } \pi_l^L}} \text{sign } K(x, V \cap L) \right) dl \right] dL.$$

But we have

$$\int_{G_L^1} \left(\sum_{\substack{x \mid x \text{ non degenerate} \\ \text{critical point of } \pi_l^L}} \text{sign } K(x, V \cap L) \right) dl = \int_{V \cap L} K(x, V \cap L) dx = L_0^+(V \cap L),$$

by the exchange formula and the fact that for almost all $l \in G_L^1$, π_l^L is a Morse function. □

Theorem 2.15. For $q \in \{0, \dots, n\}$,

$$\int_V s_{n-q}(x) dx = \binom{n}{q} \frac{o_n}{o_q} L_q^+(V),$$

$$\int_V h_{n-q}(x) dx = \binom{n}{q} \frac{o_n}{o_q} L_q(V).$$

Proof. By the reproducibility formula for s_{n-q} , we have that

$$\int_V s_{n-q}(x) dx = \text{cst} \int_{A_{n+1}^{n-q+1}} \left(\int_{V \cap L} K(x, V \cap L) dx \right) dL.$$

Hence, by the previous proposition, $\int_V s_{n-q}(x) dx$ is equal to $\text{cst} \cdot L_q^+(V)$. We compute the constant by taking $V = S^n$. □

This theorem leads to a geometric interpretation of $\int_V h_{n-q}(x) dx$ as explained in [LR], p. 597. Moreover, in [LS] and [LR], it is stated in the C^2 -case. In that situation, Lemma 2.7 relies on deep results of Mather on generic projections [Ma]. The semi-algebraic case allows an easier proof.

3. Generic projections and polar varieties

Let $f: \mathbb{R}^{n+1} \rightarrow \mathbb{R}$ be a polynomial such that $f(0) = 0$ and 0 is an isolated critical point of f . Let C_0 be $f^{-1}(0)$. For any $(n + 1 - q)$ -vector plane H , $1 \leq q \leq n - 1$, we denote by $\pi_{H^\perp}: C_0 \rightarrow H^\perp$ the orthogonal projection on H^\perp . We set also H_y for the $(n + 1 - q)$ -affine plane parallel to H and passing through $y \in H^\perp$ ($H_0 = H$). Let l be a vector line in H and let l_y be the line parallel to l passing through y . We will denote by $\pi_l^{H,y}: C_0 \cap H_y \rightarrow l_y$ the orthogonal projection on l_y . We will show that for a “generic” choice of H and l , the following property holds: the function $\pi_l^{H,y}$ admits only Morse critical points in $C_0 \cap H_y \cap B_\varepsilon^{n+1}$ for $0 < |y| \ll \varepsilon \ll 1$. We will establish this result studying generic projections and polar varieties.

Lemma 3.1. *For almost all $H \in G_{n+1}^{n+1-q}$, $1 \leq q \leq n-1$, $f|_H$ has an isolated critical point at 0.*

Proof. Let G be the map defined by

$$G: \mathbb{R}^{n+1} \times (\mathbb{R}^{n+1})^q \rightarrow \mathbb{R}^{q+1}$$

$$(x, v_1, \dots, v_q) \mapsto (f; \langle x, v_1 \rangle, \dots, \langle x, v_q \rangle).$$

The set $G^{-1}(0) \setminus (\{0\} \times (\mathbb{R}^{n+1})^q)$ is a smooth manifold of dimension $n - q + (n + 1)q$. Then we use the projection on $(\mathbb{R}^{n+1})^q$ and the Bertini–Sard theorem [BCR] and we choose $H = [\text{Span}(v_1, \dots, v_q)]^\perp$. We conclude recalling that $\{\nabla(f|_H) = 0\} \subset \{f|_H = 0\}$. \square

The following results are proved in the same way as Lemmas 2.5, 2.6 and 2.7, considering the smooth manifold $C_0 \setminus \{0\}$.

Lemma 3.2. *For almost all $H \in G_{n+1}^{n+1-q}$, $1 \leq q \leq n-1$, Σ_{H^\perp} is a smooth $(q-1)$ -dimensional or empty semi-algebraic set in the neighborhood of 0 (Σ_{H^\perp} is the critical set of π_{H^\perp}).*

Corollary 3.3. *For almost all $H \in G_{n+1}^{n+1-q}$, $1 \leq q \leq n-1$, $\Gamma_{H^\perp} = \pi_{H^\perp}(\Sigma_{H^\perp})$ is a $(q-1)$ -dimensional or empty semi-algebraic set in the neighborhood of 0.*

In the sequel, we fix a generic $(n+1-q)$ -plane H satisfying Lemmas 3.1, 3.2 and Corollary 3.3. We will assume that $H = \{x \in \mathbb{R}^{n+1} \mid x_1 = \dots = x_q = 0\}$ and so $\pi_{H^\perp}(x) = (x_1, \dots, x_q)$. Therefore the set Σ_{H^\perp} is

$$\{x \in C_0 \mid \text{rank}(\nabla f, e_1, \dots, e_q) < q + 1\}.$$

For all $l \in G_H^1$, there exists $v \in S^n \cap H$ such that the orthogonal projection $H \rightarrow l$ is given by $\langle v, x \rangle = v^*(x)$. We will work with $S^n \cap H$ and v^* . For all $v \in S^n \cap H$, we define

$$T_v = \{x \in \mathbb{R}^{n+1} \mid f(x) = 0 \text{ and } \text{rank}(\nabla f(x), e_1, \dots, e_q, v) < q + 2\}.$$

It is clear that $0 \in T_v$.

Proposition 3.4. *For almost all $v \in S^n \cap H$, $T_v \setminus \Sigma_{H^\perp}$ is a smooth q -dimensional or empty semi-algebraic set in the neighborhood of 0.*

Proof. Let G be the map defined by

$$G: \mathbb{R}^{n+1} \times (\mathbb{R}^{n+1-q})^{n-q} \rightarrow \mathbb{R}^{n-q+1},$$

$$(x, u_{q+2}, \dots, u_{n+1}) \mapsto (f; \langle \nabla f, u_{q+2} \rangle, \dots, \langle \nabla f, u_{n+1} \rangle),$$

where for $i \in \{q + 2, \dots, n + 1\}$, $u_i = (0, \dots, 0; u_i^{q+1}, \dots, u_i^{n+1})$. If $x \notin \Sigma_{H^\perp}$ then there exists $j \in \{q + 1, \dots, n + 1\}$ such that $\frac{\partial f}{\partial x_j}(x) \neq 0$. Hence $X = G^{-1}(0) \setminus [\Sigma_{H^\perp} \times (\mathbb{R}^{n+1-q})^{n-q}]$ is a smooth $[(n-q)(n+1-q)+q]$ -dimensional or empty semi-algebraic set. Let $v: \mathbb{R}^{n+1} \times (\mathbb{R}^{n+1-q})^{n-q} \rightarrow (\mathbb{R}^{n+1-q})^{n-q}$ be the projection. By the Bertini–Sard theorem, almost every $(u_{q+2}, \dots, u_{n+1}) \in (\mathbb{R}^{n+1-q})^{n-q}$ is a regular value of $v|_X$ which means that $X \cap v^{-1}((u_{q+2}, \dots, u_{n+1}))$ is a smooth q -dimensional or empty semi-algebraic set. We choose v in $[\text{Span}(u_{q+2}, \dots, u_{n+1})]^\perp \cap S^n \cap H$. \square

Proposition 3.5. *Let T'_v be the subset of $T_v \setminus \Sigma_{H^\perp}$ where the mapping $\pi_{H^\perp}: T_v \setminus \Sigma_{H^\perp} \rightarrow H^\perp$ is not regular. For almost all $v \in S^n \cap H$, the set T'_v is a union of smooth semi-algebraic sets of codimension greater than or equal to 1 in the neighborhood of 0.*

Proof. Let $v \in S^n \cap H$ be a generic vector for the previous proposition and let $(u_{q+2}, \dots, u_{n+1})$ be a $(n-q)$ -tuple such that $v \in [\text{Span}(u_{q+2}, \dots, u_{n+1})]^\perp \cap S^n \cap H$. The set T'_v is described as follows:

$$T'_v = \{x \notin \Sigma_{H^\perp} \mid f(x) = 0, \langle \nabla f(x), u_{q+2} \rangle = \dots = \langle \nabla f(x), u_{n+1} \rangle = 0, \\ \text{there is } w \in H \text{ such that } \langle \nabla f(x), w \rangle = 0 \text{ and} \\ \langle \nabla \langle \nabla f(x), u_i \rangle, w \rangle = 0 \text{ for } i \in \{q + 2, \dots, n + 1\}\}.$$

But at $x \in T_v \setminus \Sigma_{H^\perp}$, v belongs to $\text{Vect}(\nabla f(x), e_1, \dots, e_q)$ hence $\langle \nabla f(x), v \rangle \neq 0$ for otherwise $\langle v, v \rangle = 0$. If we write the element w of H as a linear combination of v and the u_i 's, we see that at $x \in T_v \setminus \Sigma_{H^\perp}$, $\langle \nabla f(x), w \rangle = 0$ if and only if $w \in \text{Vect}(u_{q+2}, \dots, u_{n+1})$. Therefore

$$T'_v = \{x \notin \Sigma_{H^\perp} \mid f(x) = 0, \langle \nabla f(x), u_{q+2} \rangle = \dots = \langle \nabla f(x), u_{n+1} \rangle = 0, \text{ there} \\ \text{is } w \in \text{Vect}(u_{q+2}, \dots, u_{n+1}) \text{ such that } \langle \nabla f(x), w \rangle = 0 \text{ and} \\ \langle \nabla \langle \nabla f(x), u_i \rangle, w \rangle = 0 \text{ for } i \in \{q + 2, \dots, n + 1\}\}.$$

We conclude mimicking Lemma 2.6. \square

Corollary 3.6. *For almost all $v \in S^n \cap H$, $\pi_{H^\perp}(T'_v)$ is a semi-algebraic set of H^\perp of dimension at most $q - 1$ in the neighborhood of 0.*

Proof. It is clear. \square

Lemma 3.7. *For almost all $v \in S^n \cap H$, $f|_{H \cap \{v^*=0\}}$ admits an isolated critical point at 0.*

Proof. Let us consider the following mapping:

$$G: \mathbb{R}^{n+1} \times \mathbb{R}^{n+1-q} \rightarrow \mathbb{R}^{q+2},$$

$$(x, v) \mapsto (f; x_1, \dots, x_q, \langle v, x \rangle).$$

Since $f|_H$ has an isolated critical point, for all $x \in f^{-1}(0) \cap H \setminus \{0\}$, there exists $j \in \{q+1, \dots, n+1\}$ such that $\frac{\partial f}{\partial x_j}(x) \neq 0$. We deduce that $G^{-1}(0) \setminus (\{0\} \times \mathbb{R}^{n+1-q})$ is a smooth manifold of dimension $2n - 2q$ and we conclude using a projection. \square

Corollary 3.8. *For almost all $H \in G_{n+1}^{n+1-q}$, $1 \leq q \leq n-1$, for almost all $l \in G_H^1$, the following properties hold: there exists a semi-algebraic set $\Delta \subset H^\perp$ which contains 0 and of dimension smaller than or equal to $q-1$ in the neighborhood of 0, there exists $0 < \varepsilon' \ll 1$ such that for all $0 < \varepsilon < \varepsilon'$, there exists $0 < y_\varepsilon \ll \varepsilon$ such that for all $y \in H^\perp \setminus \Delta$ with $0 < |y| \leq y_\varepsilon$, $C_0 \cap H_y \cap B_\varepsilon^{n+1}$ is a manifold with boundary and $\pi_l^{H,y}$ admits only Morse critical points in $C_0 \cap H_y \cap B_\varepsilon^{n+1}$.*

Proof. We choose H generic for Lemmas 3.1, 3.2 and Corollary 3.3. Therefore $f|_H$ has an isolated critical point and there exists $0 < \varepsilon' \ll 1$ such that for all $0 < \varepsilon \leq \varepsilon'$, $C_0 \cap H \cap S_\varepsilon^n$ is smooth. By transversality, there exists $0 < y' \ll \varepsilon$ such that for all y with $0 < |y| \leq y'$, $C_0 \cap H_y \cap S_\varepsilon^n$ is also smooth. Then we take $v \in S^n \cap H$ generic for Propositions 3.4 and 3.5 and we set $l = \text{Span}(v)$. Let Δ be $\Gamma_{H^\perp} \cap \pi_{H^\perp}(T'_v)$. It is a semi-algebraic set in H^\perp of dimension at most $q-1$ in the neighborhood of 0, which means that there exists $0 < y'' \ll 1$ such that $\Delta \cap B_{y''}^{n+1} \cap H^\perp$ is a semi-algebraic set of dimension at most $q-1$. We set $y_\varepsilon = \min(y', y'')$. If $y \in H^\perp \setminus \Delta$ and $0 < |y| \leq y_\varepsilon$ then $C_0 \cap H_y \cap B_\varepsilon^{n+1}$ is a smooth manifold with boundary because $y \notin \Gamma_{H^\perp}$ and $C_0 \cap H_y \cap S_\varepsilon^n$ is smooth. Furthermore $\pi_l^{H,y}$ is Morse in B_ε^{n+1} since $y \notin \pi(T'_v)$. \square

We will need also this lemma:

Lemma 3.9. *For almost all $l \in G_{n+1}^1$ with $l \perp H$, $f|_{H \oplus l}$ has an isolated critical point at 0.*

Proof. Let G be the mapping defined by

$$G: \mathbb{R}^{n+1} \times (\mathbb{R}^q)^{q-1} \rightarrow \mathbb{R}^q,$$

$$(x, w_1; \dots, w_{q-1}) \mapsto (f; \langle x, w_1 \rangle, \dots, \langle x, w_{q-1} \rangle).$$

As usual, for almost all $(w_1, \dots, w_{q-1}) \in (\mathbb{R}^q)^{q-1}$, $C_0 \cap \{\langle w_1, x \rangle = 0, \dots, \langle w_{q-1}, x \rangle = 0\}$ is smooth of codimension q outside H . But if $x \neq 0$ belongs to $H \cap C_0 \cap \{\langle w_1, x \rangle = 0, \dots, \langle w_{q-1}, x \rangle = 0\}$ then $\text{rank}(\nabla f(x), e_1, \dots, e_q) =$

$q + 1$ and therefore $\text{rank}(\nabla f(x), w_1, \dots, w_{q-1}) = q$ since $\text{Span}(w_1, \dots, w_{q-1}) \subset \text{Span}(e_1, \dots, e_q)$. We choose l in such a way that $H \oplus l = [\text{Span}(w_1, \dots, w_{q-1})]^\perp$. \square

The second part of our study on polar varieties consists in localizing the results on polar varieties of Section 2. Let k be in $\{0, \dots, n - 1\}$ and let P be in G_{n+1}^{k+1} . Let $\pi_P: C_0 \rightarrow P$ be the orthogonal projection on P . We recall that Σ_P is the set of critical points of π_P and $\Gamma_P = \pi_P(\Sigma_P)$.

Lemma 3.10. *For almost all $P \in G_{n+1}^{k+1}$, $\Sigma_P \setminus \{0\}$ is a k -dimensional submanifold in the neighborhood of 0.*

Proof. See Lemma 2.5. \square

Lemma 3.11. *For almost all $P \in G_{n+1}^{k+1}$, the set*

$$\Sigma'_P = \{x \in \Sigma_P \mid \pi_P|_{\Sigma_P} \text{ is not regular at } x\}$$

is a union of submanifolds of Σ_P of codimension greater than or equal to 1 in the neighborhood of 0.

Proof. See Lemma 2.6. \square

Lemma 3.12. *For almost all $P \in G_{n+1}^{k+1}$, Γ_P is a semi-algebraic set of dimension k in the neighborhood of 0.*

Proof. See Lemma 2.7. \square

With the definition of $i_P(x)$ given in Section 2, we have:

Lemma 3.13. *For almost all $P \in G_{n+1}^{k+1}$, there exists a semi-algebraic set $W_P \subset \overline{\Gamma_P}$ of dimension smaller than k in the neighborhood of 0 such that $\Gamma_P \setminus W_P$ is a smooth k -dimensional manifold in the neighborhood of 0 and the following functions in y ,*

$$\sum_{x \mid \pi_P|_{\Sigma_P}(x)=y} (-1)^{i_P(x)} \quad \text{and} \quad \sharp(\pi_P|_{\Sigma_P})^{-1}(y),$$

are defined and constant on each connected component of $\Gamma_P \setminus W_P$ whose closure contains 0.

Proof. Apply Lemma 2.13 to the manifold $C_0 \cap B_\varepsilon^{n+1} \setminus \{0\}$. \square

In the rest of this section, we assume that f admits an algebraically isolated critical point and we will denote by $f_{\mathbb{C}}$ its complexification (the same notation will be used for the complexification of any real algebraic mapping or set). Let us recall first two general lemmas.

Lemma 3.14. *Let $N \subset M \subset \mathbb{R}^N$ be analytic sets and let $N_{\mathbb{C}}$ and $M_{\mathbb{C}}$ be their respective complexifications. Assume that $M_{\mathbb{C}} \setminus N_{\mathbb{C}}$ is a smooth complex manifold of dimension K . Let $\pi: \mathbb{R}^N \rightarrow \mathbb{R}^P$, with $P \leq K$, be an analytic mapping and let $\pi_{\mathbb{C}}$ be its complexification. Then for almost all $\alpha \in \mathbb{R}^P$, $\pi_{\mathbb{C}}^{-1}(\alpha) \cap M_{\mathbb{C}} \setminus N_{\mathbb{C}}$ is a smooth manifold of dimension $K - P$ and $\pi^{-1}(\alpha) \cap M \setminus N$ is a smooth manifold of dimension $K - P$ (or empty).*

Proof. Let $\Sigma_{\mathbb{C}}$ be the critical set of $\pi_{\mathbb{C}}|_{M_{\mathbb{C}} \setminus N_{\mathbb{C}}}$ and let Σ be the critical set of $\pi|_{M \setminus N}$. Then $\pi_{\mathbb{C}}(\Sigma_{\mathbb{C}})$ has at most dimension $P - 1$ and $\pi_{\mathbb{C}}(\Sigma_{\mathbb{C}}) \cap \mathbb{R}^P$ is a subanalytic set of dimension at most $P - 1$, which contains $\pi(\Sigma)$. \square

Lemma 3.15. *Let $g = (g_1, \dots, g_n): \mathbb{R}^n \rightarrow \mathbb{R}^n$ be an analytic mapping such that 0 is algebraically isolated in $g^{-1}(0)$. Then, for all sufficiently small regular values δ of g ,*

$$\sharp g^{-1}(\delta) \leq \dim_{\mathbb{C}} \frac{\mathbb{C}\{x_1, \dots, x_n\}}{(g_{1\mathbb{C}}, \dots, g_{n\mathbb{C}})}.$$

Proof. Let Γ_g (resp. $\Gamma_{g_{\mathbb{C}}}$) be the discriminant of g (resp. $g_{\mathbb{C}}$); Γ_g is included in $\Gamma_{g_{\mathbb{C}}} \cap \mathbb{R}^n$. If δ does not belong to $\Gamma_{g_{\mathbb{C}}} \cap \mathbb{R}^n$ then δ is also a regular value of $g_{\mathbb{C}}$ and the result is clear. If $\delta \in (\Gamma_{g_{\mathbb{C}}} \cap \mathbb{R}^n) \setminus \Gamma_g$, δ is a regular value of g and the function $\lambda \mapsto \sharp g^{-1}(\lambda)$ is locally constant around δ . Since $\dim \Gamma_{g_{\mathbb{C}}} \cap \mathbb{R}^n < n$, there are regular values of $g_{\mathbb{C}}$ in the neighborhood of δ in \mathbb{R}^n . \square

Using these two lemmas and the machinery developed in the first part of this section, we obtain:

Corollary 3.16. *For almost all $H \in G_{n+1}^{n+1-q}$, $1 \leq q \leq n - 1$, for almost all $l \in G_H^1$, the properties of Corollary 3.8 hold. Furthermore, $C_{0\mathbb{C}} \cap H_{y_{\mathbb{C}}} \cap B_{\varepsilon}^{2(n+1)}$ is a smooth manifold with boundary and the projection $\pi_{l_{\mathbb{C}}}^{H, y_{\mathbb{C}}}: C_{0\mathbb{C}} \cap H_{y_{\mathbb{C}}} \cap B_{\varepsilon}^{2(n+1)} \rightarrow l_{y_{\mathbb{C}}}$ admits only non-degenerate critical points. The number of critical points of $\pi_l^{H, y}$ is smaller than or equal to the number of critical points of $\pi_{l_{\mathbb{C}}}^{H, y_{\mathbb{C}}}$. \square*

4. Euler characteristics and topological degrees

Let $g: (\mathbb{R}^{N+1}, 0) \rightarrow (\mathbb{R}, 0)$ be an analytic function with an isolated critical point at 0. Let us assume that $g|_{\{x_1=0\}}$ has also an isolated critical point.

Lemma 4.1. *The function $x_1|_{g^{-1}(0) \setminus \{0\}}$ has no critical point in a neighborhood of 0.*

Proof. Using the Curve Selection Lemma, it is easy to prove that the critical set of $x_1|_{g^{-1}(0)}$ lies in $\{x_1 = 0\}$. Similarly the critical set of $g|_{\{x_1=0\}}$ lies in $g^{-1}(0)$. Hence these two critical sets are the same. \square

This lemma implies that 0 is an isolated root of the mapping $G: (\mathbb{R}^{N+1}, 0) \rightarrow (\mathbb{R}^{N+1}, 0), x \mapsto (g(x), \frac{\partial g}{\partial x_{N+1}}(x), \dots, \frac{\partial g}{\partial x_{N+1}}(x))$.

Theorem 4.2. *Let $\delta, 0 < |\delta| \ll \varepsilon \ll 1$, be a regular value of $x_1|_{g^{-1}(0) \setminus \{0\}}$. Then, if $N - 1$ is even, we have*

$$\begin{aligned} \chi(g^{-1}(0) \cap \{x_1 = \delta\} \cap B_\varepsilon^{N+1}) &= 1 - \text{deg}_0 \nabla g - \text{sign}(\delta) \cdot \text{deg}_0 G, \\ \chi(\{g \geq 0\} \cap \{x_1 = \delta\} \cap B_\varepsilon^{N+1}) - \chi(\{g \leq 0\} \cap \{x_1 = \delta\} \cap B_\varepsilon^{N+1}) \\ &= \text{deg}_0 \nabla(g|_{\{x_1=0\}}). \end{aligned}$$

If $N - 1$ is odd, we have

$$\begin{aligned} \chi(g^{-1}(0) \cap \{x_1 = \delta\} \cap B_\varepsilon^{N+1}) &= 1 - \text{deg}_0 \nabla(g|_{\{x_1=0\}}), \\ \chi(\{g \geq 0\} \cap \{x_1 = \delta\} \cap B_\varepsilon^{N+1}) - \chi(\{g \leq 0\} \cap \{x_1 = \delta\} \cap B_\varepsilon^{N+1}) \\ &= \text{deg}_0 \nabla g + \text{sign}(\delta) \cdot \text{deg}_0 G. \end{aligned}$$

Proof. This is an immediate consequence of Fukui’s formula [Fu]. See [Du2], Theorem 3.2 for details. \square

We will use these results in the following form:

Corollary 4.3. *Let $\delta, 0 < \delta \ll \varepsilon \ll 1$, be a regular value of $x_1|_{g^{-1}(0) \setminus \{0\}}$. Then, if $N - 1$ is even, we have*

$$\begin{aligned} \chi(g^{-1}(0) \cap \{x_1 = \delta\} \cap B_\varepsilon^{N+1}) + \chi(g^{-1}(0) \cap \{x_1 = -\delta\} \cap B_\varepsilon^{N+1}) &= 2 - 2 \text{deg}_0 \nabla g, \\ \chi(\{g \geq 0\} \cap \{x_1 = 0\} \cap S_\varepsilon^N) - \chi(\{g \leq 0\} \cap \{x_1 = 0\} \cap S_\varepsilon^N) &= 2 \text{deg}_0 \nabla(g|_{\{x_1=0\}}). \end{aligned}$$

If $N - 1$ is odd, we have

$$\begin{aligned} \chi(g^{-1}(0) \cap \{x_1 = 0\} \cap S_\varepsilon^N) &= 2 - 2 \text{deg}_0 \nabla(g|_{\{x_1=0\}}), \\ [\chi(\{g \geq 0\} \cap \{x_1 = \delta\} \cap B_\varepsilon^{N+1}) - \chi(\{g \leq 0\} \cap \{x_1 = \delta\} \cap B_\varepsilon^{N+1})] \\ + [\chi(\{g \geq 0\} \cap \{x_1 = -\delta\} \cap B_\varepsilon^{N+1}) - \chi(\{g \leq 0\} \cap \{x_1 = -\delta\} \cap B_\varepsilon^{N+1})] \\ &= 2 \text{deg}_0 \nabla g. \end{aligned}$$

Proof. It is easy. However the reader will find in [Du1], Theorem 5.2, the argument necessary for the proof of the second point of the case $N - 1$ even. \square

5. Integrals on the singular level

We recall that $f : \mathbb{R}^{n+1} \rightarrow \mathbb{R}$ is a polynomial such that $f(0) = 0$ and 0 is an isolated critical point of f . Let C_0 be $f^{-1}(0)$ and let C_0^ε be $C_0 \cap B_\varepsilon^{n+1}$. In this section, we express

$$\lim_{\varepsilon \rightarrow 0} \frac{1}{b_k \varepsilon^k} \int_{C_0^\varepsilon \setminus \{0\}} s_{n-k}(x) dx, \quad 1 \leq k \leq n,$$

in terms of mean values of topological degrees, and we bound from above

$$\lim_{\varepsilon \rightarrow 0} \frac{1}{b_k \varepsilon^k} \int_{C_0^\varepsilon \setminus \{0\}} h_{n-k}(x) dx$$

in terms of the Milnor–Teissier numbers of $f_{\mathbb{C}}$.

5.1. Study of s_{n-k} . First we study the case $1 \leq k < n$. From Theorem 2.15,

$$\int_{C_0^\varepsilon \setminus \{0\}} s_{n-k}(x) dx = \binom{n}{k} \cdot \frac{\partial_n}{\partial_k} L_k^+(C_0^\varepsilon \setminus \{0\}).$$

We keep the notations of Sections 2 and 3: $P \in G_{n+1}^{k+1}$, $\pi_P : C_0 \rightarrow P$ is the orthogonal projection on P , Σ_P is the polar variety and $\Gamma_P = \pi_P(\Sigma_P)$. We will write

$$m^{+, \varepsilon} = \int_{\Gamma_P \cap B_\varepsilon^P} \left(\sum_{\pi_P|_{\Sigma_P}(x)=y} (-1)^{i_P(x)} \right) dy \quad \text{for } 0 < \varepsilon \ll 1.$$

Here B_ε^P is the ball of radius ε in P . Then, we have

$$\frac{1}{b_k \varepsilon^k} L_k^+(C_0^\varepsilon \setminus \{0\}) = \frac{1}{g_{n+1, k+1}} \int_{G_{n+1}^{k+1}} \frac{m^{+, \varepsilon}}{b_k \varepsilon^k} dP.$$

With the notations of Lemma 3.13, let us write $\Gamma_P \setminus W_P = \bigcup_{j=1}^{r_P} X_j^P$ in the neighborhood of 0. Moreover, on each X_j^P the integer $\sum_{\pi_P|_{\Sigma_P}(x)=y} (-1)^{i_P(x)}$, where $y \in X_j^P$, does not depend on y . We will denote it by λ_j^P . Then the following equality holds:

$$m^{+, \varepsilon} = \sum_{j=1}^{r_P} \lambda_j^P \cdot \text{vol}(X_j^P \cap B_\varepsilon^P) = \sum_{j=1}^{r_P} \lambda_j^P \cdot \int_{A_P^1} (\#X_j^P \cap l \cap B_\varepsilon^P) dl,$$

hence,

$$m^{+, \varepsilon} = \int_{A_P^1} \sum_{j=1}^{r_P} \lambda_j^P \cdot (\#X_j^P \cap l \cap B_\varepsilon^P) dl.$$

But $\sum_{j=1}^{r_P} \lambda_j^P \cdot (\#X_j^P \cap l \cap B_\varepsilon^P)$ is generically the number of critical points of the orthogonal projection $\pi_l^L : C_0 \cap L \cap B_\varepsilon^{n+1} \rightarrow l$ where $L = P^\perp \oplus l$. By Bezout's theorem, this number is smaller than or equal to $D = \deg f (\deg f - 1)^{n-k}$. Since $X_j^P \cap B_\varepsilon^P \subset B_\varepsilon^P$, there exists a constant cst such that $|m^{+, \varepsilon}| \leq cst \cdot D \cdot \varepsilon^k$ and $\frac{|m^{+, \varepsilon}|}{\varepsilon^k} \leq cst \cdot D$, this last term does not depend neither on P nor on ε . We can apply Fubini's theorem to get

$$\begin{aligned} \lim_{\varepsilon \rightarrow 0} \frac{1}{b_k \varepsilon^k} L_k^+(C_0^\varepsilon \setminus \{0\}) &= \frac{1}{g_{n+1, k+1}} \int_{G_{n+1}^{k+1}} \lim_{\varepsilon \rightarrow 0} \frac{m^{+, \varepsilon}}{b_k \varepsilon^k} dP \\ &= \frac{1}{g_{n+1, k+1}} \int_{G_{n+1}^{k+1}} \sum_{j=1}^{r_P} \lambda_j^P \cdot \lim_{\varepsilon \rightarrow 0} \frac{\text{vol}(X_j^P \cap B_\varepsilon^P)}{b_k \varepsilon^k} dP. \end{aligned}$$

Each set X_j^P is semi-algebraic of dimension k , hence by the Kurduka–Raby theorem [KR], we obtain the following proposition:

Proposition 5.1. *For $k \in \{1, \dots, n - 1\}$, $\lim_{\varepsilon \rightarrow 0} \frac{1}{b_k \varepsilon^k} L_k^+(C_0^\varepsilon \setminus \{0\})$ exists and equals*

$$\frac{1}{g_{n+1, k+1}} \int_{G_{n+1}^{k+1}} \sum_{j=1}^{r_P} \lambda_j^P \cdot \Theta_k(X_j^P, 0) dP. \quad \square$$

Now we have to compute $\Theta_k(X_j^P, 0)$ for a generic $(k + 1)$ -plane P . We will use the Cauchy–Crofton formula for the density due to Comte [Co], which can be summarized in this way in the semi-algebraic case:

Proposition 5.2. *Let X be a semi-algebraic set in \mathbb{R}^N whose closure contains 0, d -dimensional in the neighborhood of 0. For every d -dimensional vector plane Q in \mathbb{R}^N , we denote by $\pi_Q : X \rightarrow Q$ the orthogonal projection on Q . There exists a dense open semi-algebraic set \mathcal{E}_X in G_N^d such that for all $Q \in \mathcal{E}_X$, the following holds:*

- (1) *The complement of the discriminant of π_Q is a dense open semi-algebraic set of Q . We call local polar profiles its connected components whose closure contains 0. We denote them by $K_1^Q, \dots, K_{n_Q}^Q$.*
- (2) *For all $i \in \{1, \dots, n_Q\}$, the cardinal of the fibre $\pi_Q^{-1}(y)$ does not depend on y if $y \in K_i^Q$ and y is close enough to 0. We call this integer multiplicity of the polar profile and denote it by e_i^Q .*

Moreover, we have

$$\Theta_d(X, 0) = \frac{1}{g_{N, d}} \int_{G_N^d} \sum_{i=1}^{n_Q} e_i^Q \cdot \Theta_d(K_i^Q, 0) dQ. \quad \square$$

Applied to X_j^P , this gives

$$\Theta_k(X_j^P, 0) = \frac{1}{g_{k+1,k}} \int_{G_P^k} \sum_{i=1}^{n_{P,Q,j}} e_{j,i}^{P,Q} \cdot \Theta_k(K_{j,i}^{P,Q}, 0) dQ,$$

where the $K_{j,i}^{P,Q}$'s are the polar profiles and the $e_{j,i}^{P,Q}$'s are the multiplicities of $\pi_j^{P,Q}: X_j^P \rightarrow Q$. Hence for a fixed P , we obtain

$$\sum_{j=1}^{r_P} \lambda_j^P \cdot \Theta_k(X_j^P, 0) = \frac{1}{g_{k+1,k}} \int_{G_P^k} \sum_{j=1}^{r_P} \sum_{i=1}^{n_{P,Q,j}} \lambda_j^P \cdot e_{j,i}^{P,Q} \cdot \Theta_k(K_{j,i}^{P,Q}, 0) dQ.$$

Now let us fix a k -plane Q in P and let us set $l = Q^\perp$. As in Section 3, we denote by l_y the line parallel to l passing by y and H_y the $(n - k + 1)$ -affine plane $P^\perp \oplus l_y$. For $y \in K_{j,i}^{P,Q}$ close to 0 (i.e. $|y| \ll \varepsilon$), $(\pi_j^{P,Q})^{-1}(y)$ is included in X_j^P and therefore is disjoint from $\pi_P(\Sigma'_P)$ (see the notations in Sections 2 and 3). Each point in $\pi_P^{-1}[(\pi_j^{P,Q})^{-1}(y)]$ is a non-degenerate critical point of the projection $\pi_l^{H,y}: C_0^\varepsilon \cap H_y \rightarrow l_y$ (by Corollary 3.8, we can assume that $C_0^\varepsilon \cap H_y$ is smooth).

Let $\Omega_1, \dots, \Omega_\alpha$ be the connected components, whose closure contains 0, of the complement of the union of the discriminants of the projections $\pi_j^{P,Q}$. These connected components are the non-empty intersections $\bigcap_{j=1}^{r_P} K_{j,i_j}^{P,Q}$ where i_j ranges in $\{1, \dots, n_{P,Q}\}$. The set $\bigcup_{\beta=1}^\alpha \Omega_\beta$ is a dense semi-algebraic set in Q . For each $\beta \in \{1, \dots, \alpha\}$, Ω_β is equal to $\bigcap_{j,i \mid \Omega_\beta \subset K_{j,i}^{P,Q}} K_{j,i}^{P,Q}$. Let y_β be a point in Ω_β close to 0, then using Lemma 2.12 we have

$$\sum_{j,i \mid \Omega_\beta \subset K_{j,i}^{P,Q}} \lambda_j^P \cdot e_{j,i}^{P,Q} = \sum_{\substack{x \mid x \text{ non degenerate} \\ \text{critical point of } \pi_l^{H,y_\beta}}} \text{sign } K(x, C_0^\varepsilon \cap H_{y_\beta}).$$

Let us denote by I_β this integer depending only on β . Since

$$\Theta_k(K_{j,i}^{P,Q}, 0) = \sum_{\beta \mid \Omega_\beta \subset K_{j,i}^{P,Q}} \Theta_k(\Omega_\beta, 0),$$

we get

$$\begin{aligned} \sum_{j,i} \lambda_j^P \cdot e_{j,i}^{P,Q} \cdot \Theta_k(K_{j,i}^{P,Q}, 0) &= \sum_{j,i} \lambda_j^P \cdot e_{j,i}^{P,Q} \cdot \sum_{\beta \mid \Omega_\beta \subset K_{j,i}^{P,Q}} \Theta_k(\Omega_\beta, 0) \\ &= \sum_{j,i} \sum_{\beta \mid \Omega_\beta \subset K_{j,i}^{P,Q}} \lambda_j^P \cdot e_{j,i}^{P,Q} \cdot \Theta_k(\Omega_\beta, 0) \\ &= \sum_{\beta} I_\beta \cdot \Theta_k(\Omega_\beta, 0). \end{aligned}$$

Finally this gives

$$\sum_{j=1}^{r_P} \lambda_j^P \cdot \Theta_k(X_j^P, 0) = \frac{1}{g_{k+1,k}} \int_{G_P^k} \sum_{\beta} I_{\beta} \cdot \Theta_k(\Omega_{\beta}, 0) dQ,$$

and

$$\lim_{\varepsilon \rightarrow 0} \frac{1}{b_k \varepsilon^k} L_k^+(C_0^{\varepsilon} \setminus \{0\}) = \frac{1}{g_{n+1,k+1} \cdot g_{k+1,k}} \int_{G_{n+1}^{k+1}} \left(\int_{G_P^k} \sum_{\beta} I_{\beta} \cdot \Theta_k(\Omega_{\beta}, 0) dQ \right) dP.$$

The mapping $Q \rightarrow l = Q^{\perp}$ identifies $G(P, k)$ with $G(P, 1)$, hence

$$\lim_{\varepsilon \rightarrow 0} \frac{1}{b_k \varepsilon^k} L_k^+(C_0^{\varepsilon} \setminus \{0\}) = \frac{1}{g_{n+1,k+1} \cdot g_{k+1,1}} \int_{G_{n+1}^{k+1}} \left(\int_{G_P^1} \sum_{\beta} I_{\beta} \cdot \Theta_k(\Omega_{\beta}, 0) dl \right) dP.$$

Let \mathcal{F}' be the flag variety of pairs (P, l) , $P \in G_{n+1}^{k+1}$ and $l \in G_P^1$. The mapping $(P, l) \rightarrow (H, l)$ where $H = P^{\perp} \oplus l$ and $P = H^{\perp} \oplus l$ enables us to identify \mathcal{F}' with the flag variety of pairs (H, l) , $H \in G_{n+1}^{n-k+1}$ and $l \in G_H^1$. With the notations used above, we see that $H^{\perp} = Q \subset P$. Finally, we find

$$\lim_{\varepsilon \rightarrow 0} \frac{1}{b_k \varepsilon^k} L_k^+(C_0^{\varepsilon} \setminus \{0\}) = \frac{1}{g_{n+1,k+1} \cdot g_{k+1,1}} \int_{G_{n+1}^{n-k+1}} \left(\int_{G_H^1} I_{H,l} dl \right) dH,$$

where $I_{H,l}$ is defined as follows. There exists a semi-algebraic set $\tilde{\Sigma} \subset H^{\perp}$ of dimension smaller than k such that, if $H^{\perp} \setminus \tilde{\Sigma} = \bigcup_{\beta=1}^{\alpha} \Omega_{\beta}$ is the decomposition of $H^{\perp} \setminus \tilde{\Sigma}$ into its connected components, then for y_{β} close to 0 in Ω_{β} , the following sum:

$$\sum_{\substack{x \mid x \text{ non degenerate} \\ \text{critical point of } \pi_l^{H,y_{\beta}}}} \text{sign } K(x, C_0^{\varepsilon} \cap H_{y_{\beta}})$$

does not depend on the choice of y_{β} . Denoting it by I_{β} , we set

$$I_{H,l} = \sum_{\beta} I_{\beta} \cdot \Theta_k(\Omega_{\beta}, 0).$$

By Corollary 3.8, we know that for almost every pair (H, l) , there exists a semi-algebraic set $\Delta \subset H^{\perp}$, $\dim \Delta < k$, such that for all $y \notin \Delta$ close enough to 0, $C_0^{\varepsilon} \cap H_y$ is a smooth manifold with boundary and $\pi_l^{H,y} : C_0^{\varepsilon} \cap H_y \rightarrow l_y$ is a Morse function. In that case, if $n - k$ is even, one has

$$\sum_{\substack{x \mid x \text{ non degenerate} \\ \text{critical point of } \pi_l^{H,y}}} \text{sign } K(x, C_0^{\varepsilon} \cap H_y) = \chi(H_y \cap C_0^{\varepsilon}) - \chi(H_y \cap C_0^{\varepsilon} \cap \{\pi_l^{H,y} = \delta\}).$$

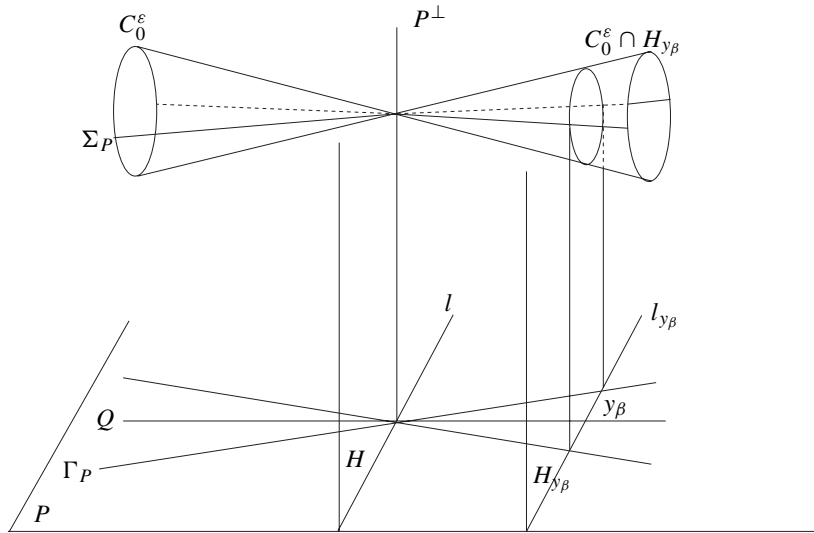

Figure 4. The case $n = 2$ and $k = 1$.

If $n - k$ is odd, one has

$$\begin{aligned} & \sum_{\substack{x \mid x \text{ non degenerate} \\ \text{critical point of } \pi_l^{H,y}}} \text{sign } K(x, C_0^\epsilon \cap H_y) \\ &= - \{ \chi(H_y \cap B_\epsilon \cap \{f \geq 0\}) - \chi(H_y \cap B_\epsilon \cap \{f \leq 0\}) \} \\ & \quad + \{ \chi(H_y \cap B_\epsilon \cap \{f \geq 0\}) \cap \{ \pi_l^{H,y} = \delta \} \\ & \quad \quad - \chi(H_y \cap B_\epsilon \cap \{f \leq 0\}) \cap \{ \pi_l^{H,y} = \delta \} \}. \end{aligned}$$

Here δ is a small regular value of $\pi_l^{H,y}$ ($|\delta| \ll |y|$). These two equalities require some explanations. By Lemma 2.3 in [Du2], we can relate the sign of $K(x, C_0^\epsilon \cap H_y)$ to the Morse index of $\pi_l^{H,y}$ at x . Then we can apply Morse theory to $\pi_l^{H,y} : C_0^\epsilon \cap H_y \rightarrow l_y$ as is done in the proof of Lemma 5.1 in [Du2]. However, as in this lemma, we have to take care about the critical points on $f^{-1}(0) \cap H_y \cap S_\epsilon^n$ and on $H_y \cap S_\epsilon^n$. If we write $l = \text{Span}(v)$, then by Lemma 3.7, $f|_{H \cap \{v^*=0\}}$ has an isolated critical point at 0. This implies that $v^*|_{C_0^\epsilon \cap H}$ has an isolated critical point at 0 by Lemma 4.1. But with our notations, $v^*|_{C_0^\epsilon \cap H}$ is $\pm \pi_l^{H,0} : C_0^\epsilon \cap H_0 \rightarrow l_0$. We can apply the same arguments as [Du1], Lemma 4.1, to get rid of these critical points on the boundary.

We will study in detail the case $n - k$ even. Since $\dim \Delta < k$, the set $\bigcup_{\beta=1}^\alpha \Omega_\beta \setminus \Delta$

is dense in H^\perp and then

$$\begin{aligned} & \lim_{\varepsilon \rightarrow 0} \frac{1}{b_k \varepsilon^k} L_k^+(C_0^\varepsilon \setminus \{0\}) \\ &= \frac{1}{g_{n+1,k+1} \cdot g_{k+1,1}} \int_{G_{n+1}^{n-k+1}} \int_{G_H^1} \sum_{\beta} \chi(H_{y_\beta} \cap C_0^\varepsilon) \Theta_k(\Omega_\beta, 0) \, dl dH \\ & - \frac{1}{g_{n+1,k+1} \cdot g_{k+1,1}} \int_{G_{n+1}^{n-k+1}} \int_{G_H^1} \sum_{\beta} \chi(H_{y_\beta} \cap C_0^\varepsilon \cap \{\pi_l^{H,y_\beta} = \delta\}) \Theta_k(\Omega_\beta, 0) \, dl dH. \end{aligned}$$

Let us compute the second term on the right-hand side. The manifold with boundary $H_{y_\beta} \cap C_0^\varepsilon \cap \{\pi_l^{H,y_\beta} = \delta\}$ has dimension $n - k - 1$, which is odd. Its Euler characteristic is half the Euler characteristic of its boundary. If y_β and δ are sufficiently small, this last Euler characteristic is the Euler characteristic of $H \cap C_0^\varepsilon \cap \{v^* = 0\}$. By Lemma 3.1 and Lemma 3.7, $f|_H$ and $f|_{H \cap \{v^*=0\}}$ have an isolated critical point at the origin. Denoting $H \cap \{v^* = 0\}$ by $l^\perp H$ (the orthogonal of l in H) and applying Corollary 4.3, we get

$$\chi(H_{y_\beta} \cap C_0^\varepsilon \cap \{\pi_l^{H,y_\beta} = \delta\}) = 1 - \text{deg}_0 \nabla(f|_{l^\perp H}).$$

Since $\sum_{\beta} \Theta_k(\Omega_\beta, 0) = 1$, we have

$$\begin{aligned} & \frac{1}{g_{n+1,k+1} \cdot g_{k+1,1}} \int_{G_{n+1}^{n-k+1}} \int_{G_H^1} \sum_{\beta} \chi(H_{y_\beta} \cap C_0^\varepsilon \cap \{\pi_{y_\beta}^l = \delta\}) \Theta_k(\Omega_\beta, 0) \, dl dH \\ &= 1 - \frac{1}{g_{n+1,k+1} \cdot g_{k+1,1}} \int_{G_{n+1}^{n-k+1}} \int_{G_H^1} \text{deg}_0 \nabla(f|_{l^\perp H}) \, dl dH \\ &= 1 - \frac{1}{g_{n+1,k+1} \cdot g_{k+1,1}} \int_{G_{n+1}^{n-k+1}} \int_{G_H^{n-k}} \text{deg}_0 \nabla(f|_K) \, dK dH. \end{aligned}$$

Let \mathcal{G} be the flag variety of pairs (H, K) , $H \in G_{n+1}^{n-k+1}$ and $K \in G_H^{n-k}$. This variety is a bundle over G_{n+1}^{n-k} , each fibre being a G_{k+1}^1 . Hence, we find

$$\begin{aligned} \int_{G_{n+1}^{n-k+1}} \int_{G_H^{n-k}} \text{deg}_0 \nabla(f|_K) \, dK dH &= \int_{G_{n+1}^{n-k}} \int_{G_{k+1}^1} \text{deg}_0 \nabla(f|_K) \, dl dK \\ &= g_{k+1,1} \int_{G_{n+1}^{n-k}} \text{deg}_0 \nabla(f|_K) \, dK. \end{aligned}$$

So our second term equals

$$1 - \frac{1}{g_{n+1,n-k}} \int_{G_{n+1}^{n-k}} \text{deg}_0 \nabla(f|_K) \, dK.$$

Let us have a look now at the first integral:

$$\mathcal{I} = \frac{1}{g_{n+1,k+1} \cdot g_{k+1,1}} \int_{G_{n+1}^{n-k+1}} \int_{G_H^1} \sum_{\beta} \chi(H_{y_{\beta}} \cap C_0^{\varepsilon}) \Theta_k(\Omega_{\beta}, 0) dl dH.$$

The sets $\Omega_1, \dots, \Omega_{\alpha}$ depend on the pair (H, l) but $\chi(H_{y_{\beta}} \cap C_0^{\varepsilon})$ depends only on y_{β} and H . We can write

$$\begin{aligned} \mathcal{I} &= \frac{g_{n-k+1,1}}{g_{n+1,k+1} \cdot g_{k+1,1}} \int_{G_{n+1}^{n-k+1}} \sum_{\beta=1}^{\alpha} \chi(H_{y_{\beta}} \cap C_0^{\varepsilon}) \Theta_k(\Omega_{\beta}, 0) dH \\ &= \frac{1}{g_{n+1,n-k+1}} \int_{G_{n+1}^{n-k+1}} \sum_{\beta=1}^{\alpha} \chi(H_{y_{\beta}} \cap C_0^{\varepsilon}) \Theta_k(\Omega_{\beta}, 0) dH, \end{aligned}$$

where, with an abuse of notation, the Ω_i 's are the connected components of $H^{\perp} \setminus \Gamma_{\pi_{H^{\perp}}}$ whose closure contains 0 ($\pi_{H^{\perp}}$ is the orthogonal projection on H^{\perp} and $\Gamma_{\pi_{H^{\perp}}}$ is its discriminant).

Let us compute $\sum_{\beta=1}^{\alpha} \chi(H_{y_{\beta}} \cap C_0^{\varepsilon}) \Theta_k(\Omega_{\beta}, 0)$. First, replacing $H^{\perp} \setminus \Gamma_{\pi_{H^{\perp}}}$ by $H^{\perp} \setminus (\Gamma_{\pi_{H^{\perp}}} \cup -\Gamma_{\pi_{H^{\perp}}})$, we can assume that for all $k \in \{1, \dots, \alpha\}$, there exists $j \in \{1, \dots, \alpha\}$ such that $-\Omega_k = \Omega_j$. Here the notation $-X$ for $X \subset H^{\perp}$ means the symmetric of X by the symmetry whose center is the origin. We have

$$\Theta_k(\Omega_{\beta}, 0) = \lim_{\varepsilon \rightarrow 0} \frac{1}{b_k \varepsilon^k} \text{vol}(\Omega_{\beta} \cap B_{\varepsilon}^k) = \lim_{\varepsilon \rightarrow 0} \frac{1}{o_{k-1} \varepsilon^{k-1}} \text{vol}(\Omega_{\beta} \cap S_{\varepsilon}^{k-1}).$$

But $\text{vol}(\Omega_{\beta} \cap S_{\varepsilon}^{k-1})$ is equal to $\varepsilon^{k-1} \int_{G_{H^{\perp}}^1} \#(\Omega_{\beta} \cap S_{\varepsilon}^{k-1} \cap l) dl$ and therefore

$$\Theta_k(\Omega_{\beta}, 0) = \frac{1}{o_{k-1}} \lim_{\varepsilon \rightarrow 0} \int_{G_{H^{\perp}}^1} \#(\Omega_{\beta} \cap S_{\varepsilon}^{k-1} \cap l) dl.$$

Since $\#(\Omega_{\beta} \cap S_{\varepsilon}^{k-1} \cap l)$ is smaller than or equal to 2 for all $l \in G_{H^{\perp}}^1$, we have

$$\Theta_k(\Omega_{\beta}, 0) = \frac{1}{o_{k-1}} \int_{G_{H^{\perp}}^1} \lim_{\varepsilon \rightarrow 0} [\#(\Omega_{\beta} \cap S_{\varepsilon}^{k-1} \cap l)] dl$$

and

$$\sum_{\beta} \chi(H_{y_{\beta}} \cap C_0^{\varepsilon}) \Theta_k(\Omega_{\beta}, 0) = \frac{1}{o_{k-1}} \int_{G_{H^{\perp}}^1} \left[\sum_{\beta} \chi(H_{y_{\beta}} \cap C_0^{\varepsilon}) \lim_{\varepsilon \rightarrow 0} \#(\Omega_{\beta} \cap S_{\varepsilon}^{k-1} \cap l) \right] dl.$$

On Ω_{β} , $\chi(H_{y_{\beta}} \cap C_0^{\varepsilon})$ does not depend on y_{β} provided it is sufficiently small.

Let $\mathcal{C}_0(\Gamma_{H^{\perp}})$ be the tangent cone of $\Gamma_{H^{\perp}}$ at 0 (see [KR] for the definition of the tangent cone). Since $\Gamma_{H^{\perp}} = -\Gamma_{H^{\perp}}$, $\mathcal{C}_0(\Gamma_{H^{\perp}})$ is an homogeneous set, i.e, if

$u \neq 0$ belongs to $\mathcal{C}_0(\Gamma_{H^\perp})$, then $\mathbb{R} \cdot u$ is included in $\mathcal{C}_0(\Gamma_{H^\perp})$. Let $\mathbb{P}\mathcal{C}_0(\Gamma_{H^\perp})$ be its projectivisation in $G^1_{H^\perp}$, we have $\dim \mathbb{P}\mathcal{C}_0(\Gamma_{H^\perp}) < k - 1$ for $\dim \mathcal{C}_0(\Gamma_{H^\perp}) \leq \dim \Gamma_{H^\perp} < k$. Let l be a line not belonging to $\mathbb{P}\mathcal{C}_0(\Gamma_{H^\perp})$, we can decompose it in the following way: $l = l^+ \sqcup \{0\} \sqcup l^-$. We assert that there exist $\varepsilon = \varepsilon(l^+)$ and Ω_β such that $l^+ \cap B_\varepsilon^{H^\perp} \subset \Omega_\beta$. Let us suppose that is not true. Then for all $\varepsilon > 0$ and for all β , there is $x_{\beta,\varepsilon}$ in l^+ such that $|x_{\beta,\varepsilon}| < \varepsilon$ and $x_{\beta,\varepsilon} \notin \Omega_\beta$. But for ε small enough, $l^+ \cap B_\varepsilon^{H^\perp}$ is not included in Γ_{H^\perp} because otherwise l^+ would be included in $\mathcal{C}_0(\Gamma_{H^\perp})$ and l would belong to $\mathbb{P}\mathcal{C}_0(\Gamma_{H^\perp})$. Hence for ε small enough, there exist $\beta_0 = \beta_0(\varepsilon)$ and $x'_{\beta_0,\varepsilon}$ in Ω_{β_0} such that $x'_{\beta_0,\varepsilon} \in l^+ \cap B_\varepsilon^{H^\perp}$. Let I be the interval in l^+ with extremities $x'_{\beta_0,\varepsilon}$ and $x_{\beta_0,\varepsilon}$. If $I \cap \Gamma_{H^\perp} = \emptyset$ then, since I is connected and $I \cap \Omega_{\beta_0} \neq \emptyset$, I is included in Ω_{β_0} , which is impossible for $x_{\beta_0,\varepsilon} \notin \Omega_{\beta_0}$. So $I \cap \Gamma_{H^\perp}$ and $l^+ \cap B_\varepsilon^{H^\perp} \cap \Gamma_{H^\perp}$ are not empty. Finally, for ε small enough, there exists x_ε in $l^+ \cap B_\varepsilon^{H^\perp} \cap \Gamma_{H^\perp}$ and so $l^+ \subset \mathcal{C}_0\Gamma_{H^\perp}$, which contradicts the fact that $l \notin \mathbb{P}\mathcal{C}_0(\Gamma_{H^\perp})$. Our assertion is proven. It clearly implies that $l \subset \Omega_\beta \cup \{0\} \cup -\Omega_\beta$.

Let us compute $\sum_\beta \chi(H_{y_\beta} \cap C_0^\varepsilon) \lim_{\varepsilon \rightarrow 0} \#(\Omega_\beta \cap S_\varepsilon^{k-1} \cap l)$ for $l \notin \mathbb{P}\mathcal{C}_0(\Gamma_{H^\perp})$. Since there exists β such that $l \subset \Omega_\beta \cup \{0\} \cup -\Omega_\beta$, this sum is equal to

$$\chi(H_{y_\beta} \cap C_0^\varepsilon) + \chi(H_{y_{\beta'}} \cap C_0^\varepsilon), \quad \text{where } \Omega_{\beta'} = -\Omega_\beta.$$

Let us suppose that $H = \{x_1 = 0, \dots, x_k = 0\}$, in that case $H^\perp = \{x_{k+1} = 0, \dots, x_{n+1} = 0\} = \text{Span}(e_1, \dots, e_k)$. Suppose that $l = \text{Span}(e_1) = \{x_2 = \dots = x_k = 0\}$ in H^\perp . Since $l \subset \Omega_\beta \cup \{0\} \cup \Omega_{\beta'}$, we can choose y_β and $y_{\beta'}$ of the form $y_\beta = (\delta, 0, \dots, 0)$ and $y_{\beta'} = -y_\beta = -(\delta, 0, \dots, 0)$, where $0 < \delta \ll \varepsilon \ll 1$. Then, we have

$$H_{y_\beta} \cap C_0^\varepsilon = C_0^\varepsilon \cap \{x_1 = \delta, x_2 = 0, \dots, x_k = 0\}$$

and

$$H_{y_{\beta'}} \cap C_0^\varepsilon = C_0^\varepsilon \cap \{x_1 = -\delta, x_2 = 0, \dots, x_k = 0\}.$$

By Lemma 3.1 and Lemma 3.9, $f|_H$ and $f|_{H \oplus l}$ have an isolated critical point at 0. We can apply Corollary 4.3 and get

$$\chi(H_{y_\beta} \cap C_0^\varepsilon) + \chi(H_{y_{\beta'}} \cap C_0^\varepsilon) = 2 - 2 \deg_0 \nabla(f|_{\{x_2=0, \dots, x_k=0\}}) = 2 - 2 \deg_0 \nabla(f|_{H \oplus l}).$$

Finally, we find:

$$\begin{aligned} \sum_\beta \chi(H_{y_\beta} \cap C_0^\varepsilon) \Theta_k(\Omega_\beta, 0) &= \frac{2}{o_{k-1}} \int_{G^1_{H^\perp}} (1 - \deg_0 \nabla(f|_{H \oplus l})) dl \\ &= 1 - \frac{2}{o_{k-1}} \int_{G^1_{H^\perp}} \deg_0 \nabla(f|_{H \oplus l}) dl \end{aligned}$$

and

$$\mathcal{I} = 1 - \frac{1}{g_{n+1,n-k+1} \cdot g_{k,1}} \int_{G_{n+1}^{n-k+1}} \int_{G_{H^\perp}^1} \deg_0 \nabla(f|_{H \oplus l}) dldH.$$

Let \mathcal{H} be the flag variety of pairs (K, H) , $K \in G_{n+1}^{n-k+2}$ and $H \in G_K^{n-k+1}$. This variety is a bundle over G_{n+1}^{n-k+1} , each fibre being a G_k^1 . Hence, we have

$$\begin{aligned} \int_{G_{n+1}^{n-k+1}} \int_{G_{H^\perp}^1} \deg_0 \nabla(f|_{H \oplus l}) dldH &= \int_{G_{n+1}^{n-k+2}} \int_{G_K^{n-k+1}} \deg_0 \nabla(f|_K) dHdK \\ &= g_{n-k+2,n-k+1} \int_{G_{n+1}^{n-k+2}} \deg_0 \nabla(f|_K) dK, \end{aligned}$$

and

$$\begin{aligned} \mathcal{I} &= 1 - \frac{g_{n-k+2,n-k+1}}{g_{n+1,n-k+1} \cdot g_{k,1}} \int_{G_{n+1}^{n-k+2}} \deg_0 \nabla(f|_K) dK \\ &= 1 - \frac{1}{g_{n+1,n-k+2}} \int_{G_{n+1}^{n-k+2}} \deg_0 \nabla(f|_K) dK. \end{aligned}$$

We can study the case of $n - k$ odd in the same way, using the second part of Corollary 4.3. We have proved:

Theorem 5.3. For $1 \leq k < n$,

$$\begin{aligned} \lim_{\varepsilon \rightarrow 0} \frac{1}{b_k \varepsilon^k} L_k^+(C_0^\varepsilon \setminus \{0\}) &= -\frac{1}{g_{n+1,n-k+2}} \int_{G_{n+1}^{n-k+2}} \deg_0 \nabla(f|_K) dK \\ &\quad + \frac{1}{g_{n+1,n-k}} \int_{G_{n+1}^{n-k}} \deg_0 \nabla(f|_H) dH. \quad \square \end{aligned}$$

Corollary 5.4. For $1 \leq k < n$,

$$\begin{aligned} \lim_{\varepsilon \rightarrow 0} \frac{1}{b_k \varepsilon^k} \int_{C_0^\varepsilon \setminus \{0\}} s_{n-k}(x) dx &= -\binom{n}{k} \cdot \frac{o_n}{o_k} \cdot \frac{1}{g_{n+1,n-k+2}} \int_{G_{n+1}^{n-k+2}} \deg_0 \nabla(f|_K) dK \\ &\quad + \binom{n}{k} \cdot \frac{o_n}{o_k} \cdot \frac{1}{g_{n+1,n-k}} \int_{G_{n+1}^{n-k}} \deg_0 \nabla(f|_H) dH. \quad \square \end{aligned}$$

It remains to consider the case $k = n$. Here, we have

$$\lim_{\varepsilon \rightarrow 0} \frac{1}{b_n \varepsilon^n} \int_{C_0^\varepsilon \setminus \{0\}} s_0(x) dx = \lim_{\varepsilon \rightarrow 0} \frac{\text{vol}(C_0 \cap B_\varepsilon^{n+1})}{b_n \varepsilon^n} = \Theta_n(C_0, 0).$$

We use the Cauchy–Crofton formula for the density:

$$\Theta_n(C_0, 0) = \frac{1}{g_{n+1,n}} \int_{G_{n+1}^n} \sum_{j=1}^{n_P} e_j^P \cdot \Theta_n(K_j^P, 0) dP,$$

where the K_j 's are the polar profiles and e_j 's are the multiplicities of $\pi_P: C_0 \rightarrow P$. Let Γ_P be the discriminant of π_P . As before, we can assume that $\Gamma_P = -\Gamma_P$ and so for all $j \in \{1, \dots, n_P\}$, there exists $i \in \{1, \dots, n_P\}$ such that $K_j^P = -K_i^P$. We have

$$\Theta_n(K_j^P, 0) = \frac{1}{o_{n-1}} \int_{G_P^1} \left[\lim_{\varepsilon \rightarrow 0} \sharp(K_j^P \cap S_\varepsilon^{n-1} \cap l) \right] dl,$$

and

$$\sum_{j=1}^{n_P} e_j^P \cdot \Theta_n(K_j^P, 0) = \frac{1}{o_{n-1}} \int_{G_P^1} \left[\sum_{j=1}^{n_P} e_j^P \cdot \lim_{\varepsilon \rightarrow 0} \sharp(K_j^P \cap S_\varepsilon^{n-1} \cap l) \right] dl.$$

Let l be a line not belonging to $\mathbb{P}\mathcal{C}_0(\Gamma_P)$, then there exist j and k in $\{1, \dots, n_P\}$ such that $K_k^P = -K_j^P$ and such that $l \subset K_j^P \cup K_k^P \cup \{0\}$. Let us assume that $P = \{x_{n+1} = 0\}$ and that $l = \text{Span}(e_1) = \{x_2 = \dots = x_n = 0\}$ in P . Let $y = (\delta, 0, \dots, 0)$, $0 < \delta \ll \varepsilon \ll 1$, be in $K_j^P \cap l$. Then $-y$ belongs to $K_k^P \cap l$. Moreover e_j^P is equal to $\sharp\pi_P^{-1}(y)$ and e_k^P to $\sharp\pi_P^{-1}(-y)$, hence e_j^P is equal to $\sharp C_0^\varepsilon \cap \{x_1 = \delta, x_2 = 0, \dots, x_n = 0\}$ and e_k^P to $\sharp C_0^\varepsilon \cap \{x_1 = -\delta, x_2 = 0, \dots, x_n = 0\}$. By Corollary 4.3, we find that

$$e_j^P + e_k^P = 2 - 2 \deg_0 \nabla(f|_{\{x_2=0, \dots, x_n=0\}}) = 2 - 2 \deg_0 \nabla(f|_{l \oplus P^\perp}),$$

$$\sum_{j=1}^{n_P} e_j^P \lim_{\varepsilon \rightarrow 0} \sharp(K_j^P \cap S_\varepsilon^{n-1} \cap l) = 2 - 2 \deg_0 \nabla(f|_{l \oplus P^\perp}),$$

and, finally,

$$\Theta_n(C_0, 0) = 1 - \frac{1}{g_{n+1,n} \cdot g_{n,1}} \int_{G_{n+1}^n} \int_{G_P^1} \deg_0 \nabla(f|_{l \oplus P^\perp}) dl dP.$$

The same argument as above shows that:

Theorem 5.5.

$$\Theta_n(C_0, 0) = 1 - \frac{1}{g_{n+1,2}} \int_{G_{n+1}^2} \deg_0 \nabla(f|_K) dK. \quad \square$$

5.2. Study of h_{n-k} . We study the case $1 \leq k < n$. Theorem 2.15 gives

$$\int_{C_0^\varepsilon \setminus \{0\}} h_{n-k}(x) dx = \binom{n}{k} \cdot \frac{o_n}{o_k} L_k(C_0^\varepsilon \setminus \{0\}).$$

With the notations used in Subsection 5.1., we can prove that

$$\frac{1}{b_k \varepsilon^k} L_k(C_0^\varepsilon \setminus \{0\}) = \frac{1}{g_{n+1,k+1}} \int_{G_{n+1}^{k+1}} \frac{m^\varepsilon(P)}{b_k \varepsilon^k},$$

where

$$m^\varepsilon(P) = \int_{\Gamma \cap B_\varepsilon^P} \sharp(\pi_P|_{\Sigma_P})^{-1}(y) dy$$

for $0 < \varepsilon \ll 1$. With the method applied in the previous subsection, we get:

Proposition 5.6. *For $k \in \{1, \dots, n-1\}$, $\lim_{\varepsilon \rightarrow 0} \frac{1}{b_k \varepsilon^k} L_k(C_0^\varepsilon \setminus \{0\})$ exists and equals*

$$\frac{1}{g_{n+1,k+1}} \int_{G_{n+1}^{k+1}} \sum_{j=1}^{r_P} \mu_j^P \cdot \Theta_k(X_j^P, 0) dP,$$

where μ_j^P is the integer $\sharp(\pi_P|_{\Sigma_P})^{-1}(y)$, which does not depend on the choice of the point y in X_j^P , provided y is close enough to 0. \square

Then, everywhere replacing λ_j^P by μ_j^P , we obtain

$$\lim_{\varepsilon \rightarrow 0} \frac{1}{b_k \varepsilon^k} L_k(C_0^\varepsilon \setminus \{0\}) = \frac{1}{g_{n+1,k+1} \cdot g_{k+1,1}} \int_{G_{n+1}^{n-k+1}} \int_{G_H^1} J_{H,l} dl dH,$$

where $J_{H,l}$ is defined as follows. There exists a semi-algebraic set $\tilde{\Sigma} \subset H^\perp$ of dimension smaller than k such that, if $H^\perp \setminus \tilde{\Sigma} = \bigcup_{\beta=1}^\alpha \Omega_\beta$ is the decomposition of $H^\perp \setminus \tilde{\Sigma}$ in its connected components, then for y_β close to 0 in Ω_β , the following integer:

$$\sharp\{x \mid x \text{ non degenerate critical point of } \pi_l^{H,y_\beta}\}$$

does not depend on the choice of y_β . Denoting it by J_β , we set

$$J_{H,l} = \sum_{\beta} J_\beta \cdot \Theta_k(\Omega_\beta, 0).$$

By Corollary 3.16, we know that for almost all pairs (H, l) , there exists a semi-algebraic set $\Delta \subset H^\perp$, $\dim \Delta < k$, such that for all y not in Δ and close to 0, $C_0^\varepsilon \cap H_y$ and $C_{0\mathbb{C}} \cap H_{y\mathbb{C}} \cap B_\varepsilon^{2(n+1)}$ are smooth manifolds with boundary and $\pi_l^{H,y} : C_0^\varepsilon \cap H_y \rightarrow l_y$

and $\pi_{l_{\mathbb{C}}}^{H,y_{\mathbb{C}}}: C_{0\mathbb{C}} \cap H_{y_{\mathbb{C}}} \cap B_{\varepsilon}^{2(n+1)} \rightarrow l_{y_{\mathbb{C}}}$ are Morse functions. Furthermore, the following inequality holds:

$$\begin{aligned} \# \{x \mid x \text{ non degenerate critical point of } \pi_l^{H,y}\} \cap B_{\varepsilon}^{n+1} \\ \leq \# \{z \mid z \text{ non degenerate critical point of } \pi_{l_{\mathbb{C}}}^{H,y_{\mathbb{C}}}\} \cap B_{\varepsilon}^{2(n+1)}. \end{aligned}$$

Let us express the right hand side of the inequality in terms of the Milnor–Teissier numbers. For convenience we will assume that $H = \{x_1 = 0, \dots, x_k = 0\}$ and that $l = \text{Vect}(e_{k+1}) = \{x_{k+2} = 0, \dots, x_{n+1} = 0\}$. Thus, our right-hand side is the number of elements in

$$\{f_{\mathbb{C}} = 0\} \cap \{x_1 = y_1, \dots, x_k = y_k\} \cap \left\{ \frac{\partial f_{\mathbb{C}}}{\partial x_{k+2}} = 0, \dots, \frac{\partial f_{\mathbb{C}}}{\partial x_{n+1}} = 0 \right\} \cap B_{\varepsilon}^{2(n+1)},$$

where $0 < \|(y_1, \dots, y_k)\| \ll \varepsilon \ll 1$. Generically this is the dimension of the algebra

$$\frac{\mathbb{C}\{x_1, \dots, x_{n+1}\}}{\left(f, x_1, \dots, x_k, \frac{\partial f_{\mathbb{C}}}{\partial x_{k+2}}, \dots, \frac{\partial f_{\mathbb{C}}}{\partial x_{n+1}}\right)}.$$

Applying Teissier’s lemma [Te] to $f_{\mathbb{C}}|_H$, it follows that this dimension is equal to $\mu^{(n-k+1)}(f_{\mathbb{C}}) + \mu^{(n-k)}(f_{\mathbb{C}})$. This enables us to bound J_{β} generically and since $\sum_{\beta} \Theta_k(\Omega_{\beta}, 0) = 1$, we get:

Theorem 5.7. For $k \in \{1, \dots, n - 1\}$,

$$\lim_{\varepsilon \rightarrow 0} \frac{1}{b_k \varepsilon^k} L_k(C_0^{\varepsilon} \setminus \{0\}) \leq \mu^{(n-k+1)}(f_{\mathbb{C}}) + \mu^{(n-k)}(f_{\mathbb{C}}). \quad \square$$

Corollary 5.8. For $k \in \{1, \dots, n - 1\}$,

$$\lim_{\varepsilon \rightarrow 0} \frac{1}{b_k \varepsilon^k} \int_{C_0^{\varepsilon} \setminus \{0\}} h_{n-k}(x) dx \leq \binom{n}{k} \cdot \frac{o_n}{o_k} \cdot (\mu^{(n-k+1)}(f_{\mathbb{C}}) + \mu^{(n-k)}(f_{\mathbb{C}})). \quad \square$$

It remains to study the case $k = n$, i.e. to bound $\Theta_n(C_0, 0)$ in terms of the Milnor–Teissier numbers. We will not go into details but just mention that using the Cauchy–Crofton formula for the density and the fact that generically $e_j^P \leq e(f_{\mathbb{C}})$ ($e(f_{\mathbb{C}})$ is the multiplicity of $f_{\mathbb{C}}$), we get:

Theorem 5.9.

$$\Theta_n(V, 0) \leq e(f_{\mathbb{C}}) = \mu^{(1)}(f_{\mathbb{C}}) + \mu^{(0)}(f_{\mathbb{C}}). \quad \square$$

6. Integrals on the Milnor fibre and on the singular level

We recall that (t, x_1, \dots, x_{n+1}) is a coordinate system in \mathbb{R}^{2+n} and that $F: \mathbb{R}^{2+n} \rightarrow \mathbb{R}$ is a polynomial such that for all $x \in \mathbb{R}^{n+1}$, $f(x) = F(0, x)$. We assume that $\bar{H} = (F, \frac{\partial F}{\partial x_1}, \dots, \frac{\partial F}{\partial x_{n+1}})$ has an isolated zero at 0 which implies that ∇F also has an isolated zero at 0. We denote by $f_t: \mathbb{R}^{n+1} \rightarrow \mathbb{R}$ the deformation given by $f_t(x) = F(t, x)$. Let $C_0 = f^{-1}(0)$, $C_0^\varepsilon = C_0 \cap B_\varepsilon^{n+1}$, $C_t = f_t^{-1}(0)$ and $C_t^\varepsilon = C_t \cap B_\varepsilon^{n+1}$.

Proposition 6.1. *For $k \in \{1, \dots, n\}$, one has:*

$$\lim_{\varepsilon \rightarrow 0} \lim_{t \rightarrow 0} \frac{1}{\varepsilon^k} \int_{C_t^\varepsilon} s_{n-k}(x) dx = \lim_{\varepsilon \rightarrow 0} \frac{1}{\varepsilon^k} \int_{C_0^\varepsilon \setminus \{0\}} s_{n-k}(x) dx,$$

$$\lim_{\varepsilon \rightarrow 0} \lim_{t \rightarrow 0} \frac{1}{\varepsilon^k} \int_{C_t^\varepsilon} h_{n-k}(x) dx = \lim_{\varepsilon \rightarrow 0} \frac{1}{\varepsilon^k} \int_{C_0^\varepsilon \setminus \{0\}} h_{n-k}(x) dx.$$

Proof. We prove the result for s_{n-k} . For $0 < \varepsilon' < \varepsilon$, we will denote by $C_t^{\varepsilon, \varepsilon'}$ the set $C_t \cap \{\varepsilon' \leq \omega \leq \varepsilon\}$, where $\omega = \sqrt{x_1^2 + \dots + x_{n+1}^2}$. Then for $0 < \varepsilon' \ll \varepsilon \ll 1$, $C_0^{\varepsilon, \varepsilon'}$ is a smooth manifold with boundary (possibly empty). This implies that for $0 < t \ll \varepsilon'$, $C_t^{\varepsilon, \varepsilon'}$ is also a smooth manifold with boundary.

The proof decomposes into three steps.

First step. If $0 < \varepsilon' \ll \varepsilon$, i.e. $\varepsilon' = o(\varepsilon)$, then

$$\lim_{\varepsilon \rightarrow 0} \frac{1}{\varepsilon^k} \int_{C_0^{\varepsilon, \varepsilon'}} s_{n-k}(x) dx = \lim_{\varepsilon \rightarrow 0} \frac{1}{\varepsilon^k} \int_{C_0^{\varepsilon, \varepsilon'}} s_{n-k}(x) dx.$$

We have

$$\frac{1}{\varepsilon^k} \int_{C_0^\varepsilon \setminus \{0\}} s_{n-k}(x) dx = \frac{1}{\varepsilon^k} \int_{C_0^{\varepsilon, \varepsilon'}} s_{n-k}(x) dx + \frac{1}{\varepsilon^k} \int_{C_0^{\varepsilon'} \setminus \{0\}} s_{n-k}(x) dx.$$

The second term of the right-hand side can be written as follows:

$$\frac{1}{\varepsilon^k} \int_{C_0^{\varepsilon'} \setminus \{0\}} s_{n-k}(x) dx = \left(\frac{\varepsilon'}{\varepsilon}\right)^k \left(\frac{1}{\varepsilon'^k} \int_{C_0^{\varepsilon'} \setminus \{0\}} s_{n-k}(x) dx\right).$$

We have proved in the previous section that $\lim_{\varepsilon' \rightarrow 0} \frac{1}{\varepsilon'^k} \int_{C_0^{\varepsilon'} \setminus \{0\}} s_{n-k}(x) dx$ exists and is finite. Since as ε tends to 0, ε' and $\frac{\varepsilon'}{\varepsilon}$ tend to 0, it is easy to see that

$$\lim_{\varepsilon \rightarrow 0} \frac{1}{\varepsilon^k} \int_{C_0^{\varepsilon'} \setminus \{0\}} s_{n-k}(x) dx = 0.$$

Second step. If $0 < |t| \ll \varepsilon' \ll \varepsilon$, then

$$\lim_{\varepsilon \rightarrow 0} \lim_{t \rightarrow 0} \frac{1}{\varepsilon^k} \int_{C_t^\varepsilon} s_{n-k}(x) dx = \lim_{\varepsilon \rightarrow 0} \lim_{t \rightarrow 0} \frac{1}{\varepsilon^k} \int_{C_t^{\varepsilon, \varepsilon'}} s_{n-k}(x) dx.$$

As above, we have

$$\frac{1}{\varepsilon^k} \int_{C_t^\varepsilon} s_{n-k}(x) dx = \frac{1}{\varepsilon^k} \int_{C_t^{\varepsilon, \varepsilon'}} s_{n-k}(x) dx + \left(\frac{\varepsilon'}{\varepsilon}\right)^k \left(\frac{1}{\varepsilon'^k} \int_{C_t^{\varepsilon'}} s_{n-k}(x) dx\right).$$

Applying the argument of Proposition 5.1 to $C_t^{\varepsilon'}$ instead of $C_0^\varepsilon \setminus \{0\}$, we find that

$$\left| \frac{1}{\varepsilon'^k} \int_{C_t^{\varepsilon'}} s_{n-k}(x) dx \right| \leq \text{cst} \cdot \deg f_t (\deg f_t - 1)^{n-k}.$$

But $\deg f_t$ is smaller than $\deg F$, hence

$$\left| \frac{1}{\varepsilon'^k} \int_{C_t^{\varepsilon'}} s_{n-k}(x) dx \right| \leq \text{cst} \cdot \deg F (\deg F - 1)^{n-k}.$$

Since $\left(\frac{\varepsilon'}{\varepsilon}\right)^k$ tends to 0, this proves the second step.

Third step. If $0 < |t| \ll \varepsilon' \ll \varepsilon$, then

$$\lim_{t \rightarrow 0} \int_{C_t^{\varepsilon, \varepsilon'}} s_{n-k}(x) dx = \int_{C_0^{\varepsilon, \varepsilon'}} s_{n-k}(x) dx.$$

In order to prove this equality, we will first show that

$$\lim_{t \rightarrow 0} \int_{C_t^{\varepsilon, \varepsilon'}} K(x) dx = \int_{C_0^{\varepsilon, \varepsilon'}} K(x) dx,$$

and then we will use the reproducibility formula for s_{n-k} (Proposition 2.4).

Let us explain briefly why the above equality is true. Let $W = F^{-1}(0)$ and for $0 < \varepsilon' \ll \varepsilon \ll 1$, let $W^{\varepsilon, \varepsilon'} = W \cap \{\varepsilon' \leq \omega \leq \varepsilon\}$. For δ such that $0 \leq |\delta| \ll \varepsilon'$, let $D_\delta^{\varepsilon, \varepsilon'}$ be the smooth manifold with boundary $W^{\varepsilon, \varepsilon'} \cap \{t = \delta\}$. The restriction of the projection $\pi : \mathbb{R}^{2+n} \rightarrow \mathbb{R}^{1+n}$, $(t, x) \mapsto x$ to the manifold $D_\delta^{\varepsilon, \varepsilon'}$ is a diffeomorphism onto $C_\delta^{\varepsilon, \varepsilon'}$.

Let us recall that for all $v \in S^n$ and for $x \in \mathbb{R}^{n+1}$, $v^*(x) = \langle v, x \rangle$. We will also denote by v^* the function $\mathbb{R}^{2+n} \rightarrow \mathbb{R}$, $(t, x) \mapsto \langle v, x \rangle$. For all $v \in S^n$, we define the following polar set:

$$Z_v = \{(t, x) \in W^{\varepsilon, \varepsilon'} \mid \text{rank}(\nabla t, \nabla F, v) < 3\}.$$

Using techniques similar to the ones developed in Section 3 and in [Du2] p. 854–855, we can prove the following results.

Lemma 6.2. *There exists an open dense semi-algebraic set O in S^n such that for all $v \in O$, Z_v is empty or a smooth semi-algebraic curve in a neighborhood of $D_0^{\varepsilon, \varepsilon'}$.*

Lemma 6.3. *For all $v \in O$, there exists δ' with $0 < \delta' \ll \varepsilon'$ such that for all δ with $0 \leq |\delta| \leq \delta'$, the critical points of $v^*|_{D_\delta^{\varepsilon, \varepsilon'}}$ lying in the interior of $D_\delta^{\varepsilon, \varepsilon'}$ are Morse critical points.*

The last lemma has this direct corollary.

Lemma 6.4. *For all $v \in O$, there exists t' with $0 < t' \ll \varepsilon'$ such that for all t with $0 \leq |t| \leq t'$, the critical points of $v^*|_{C_t^{\varepsilon, \varepsilon'}}$ lying in the interior of $C_t^{\varepsilon, \varepsilon'}$ are Morse critical points.*

Let γ_t be the Gauss mapping:

$$\begin{aligned} \gamma_t : C_t^{\varepsilon, \varepsilon'} &\rightarrow S^n, \\ x &\mapsto \frac{\nabla f_t(x)}{\|\nabla f_t(x)\|}. \end{aligned}$$

Let us fix v in the open dense semi-algebraic set $O \setminus (\gamma_0(C_0 \cap S_\varepsilon^n) \cup \gamma_0(C_0 \cap S_{\varepsilon'}^n))$. Let $\{p_1^t, \dots, p_{r_t}^t\}$ be the set of points in the interior of $C_t^{\varepsilon, \varepsilon'}$ that are sent to v or $-v$ by γ_t . Let $I_{v,t}$ be defined by $I_{v,t} = \sum_i^{r_t} \deg(\gamma_t, p_i^t)$ where $\deg(\gamma_t, p_i^t)$ is the local topological degree of γ_t at the point p_i^t . By the exchange formula, we have

$$\int_{C_t^{\varepsilon, \varepsilon'}} K(x) dx = \frac{1}{2} \int_{S^n} I_{v,t} dv.$$

By Bezout's theorem, $|I_{v,t}|$ is lower than $\deg F \cdot (\deg F - 1)^n$ and then, by Lebesgue's theorem,

$$\lim_{t \rightarrow 0} \int_{C_t^{\varepsilon, \varepsilon'}} K(x) dx = \frac{1}{2} \int_{S^n} \lim_{t \rightarrow 0} I_{v,t} dv.$$

It remains to prove that $\lim_{t \rightarrow 0} I_{v,t} = I_{v,0}$. Observe that the set $\pi(Z_v)$ has a finite number of connected components $Z_{v,1}, \dots, Z_{v,r}$ which are either 0-dimensional or 1-dimensional. Furthermore these connected components do not intersect the boundary of $C_0^{\varepsilon, \varepsilon'}$ because $v \notin \gamma_0(C_0 \cap S_\varepsilon^n) \cup \gamma_0(C_0 \cap S_{\varepsilon'}^n)$. Hence for t such that $0 \leq |t| \ll \varepsilon'$, they do not intersect the boundary of $C_t^{\varepsilon, \varepsilon'}$. Furthermore each of the $Z_{v,i}$'s intersects $C_t^{\varepsilon, \varepsilon'}$ in exactly one point and the union of these intersection points is exactly the set $\{p_1^t, \dots, p_{r_t}^t\}$. Therefore, r_t is equal to r and we can write $\{p_i^t\} = Z_{v,i} \cap C_t^{\varepsilon, \varepsilon'}$, where p_i^t tends to p_i^0 as t tends to 0. Since for t sufficiently small, $\deg(\gamma_t, p_i^t) = \deg(\gamma_0, p_i^0)$, it is easy to conclude that $\lim_{t \rightarrow 0} I_{v,t} = I_{v,0}$.

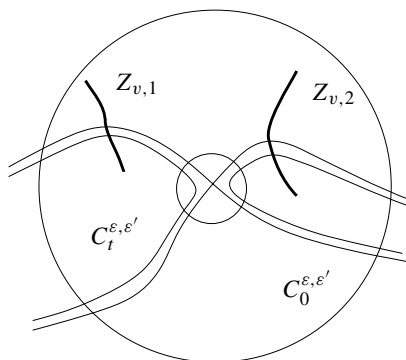

Figure 5. The sets $Z_{v,i}$.

By the reproducibility formula for s_{n-k} , we have that for $0 \leq |t| \ll \epsilon' \ll \epsilon$:

$$\int_{C_t^{\epsilon, \epsilon'}} s_{n-k}(x) dx = \text{cst} \cdot \int_{A_{n+1}^{n-k+1}} \left(\int_{C_t^{\epsilon, \epsilon'} \cap L} K(x, C_t^{\epsilon, \epsilon'} \cap L) dx \right) dL.$$

Using Bezout's theorem and the exchange formula, we see that

$$\left| \int_{C_t^{\epsilon, \epsilon'} \cap L} K(x, C_t^{\epsilon, \epsilon'} \cap L) dx \right|$$

is bounded by a constant which does not depend neither on t nor on L . Applying Lebesgue's theorem, we obtain

$$\lim_{t \rightarrow 0} \int_{C_t^{\epsilon, \epsilon'}} s_{n-k}(x) dx = \text{cst} \cdot \int_{A_{n+1}^{n-k+1}} \left(\lim_{t \rightarrow 0} \int_{C_t^{\epsilon, \epsilon'} \cap L} K(x, C_t^{\epsilon, \epsilon'} \cap L) dx \right) dL.$$

Replacing \mathbb{R}^{1+n} by the affine subspace L in the above study, we find that

$$\lim_{t \rightarrow 0} \int_{C_t^{\epsilon, \epsilon'} \cap L} K(x, C_t^{\epsilon, \epsilon'} \cap L) dx = \int_{C_0^{\epsilon, \epsilon'} \cap L} K(x, C_0^{\epsilon, \epsilon'} \cap L) dx.$$

This ends the proof of the third step and the proof of the proposition. \square

7. Curvature integrals on the real Milnor fibre

In this section we state our main results. First we state real versions of the Griffiths–Loeser formulas.

Theorem 7.1. For $k \in \{1, \dots, n-1\}$,

$$\begin{aligned} \frac{o_k}{\binom{n}{k} o_n} \lim_{\varepsilon \rightarrow 0} \lim_{t \rightarrow 0} \frac{1}{b_k \varepsilon^k} \int_{C_t^\varepsilon} s_{n-k}(x) dx &= - \frac{1}{g_{n+1, n-k+2}} \int_{G_{n+1}^{n-k+2}} \text{deg}_0 \nabla(f|_K) dK \\ &+ \frac{1}{g_{n+1, n-k}} \int_{G_{n+1}^{n-k}} \text{deg}_0 \nabla(f|_H) dH, \\ \frac{o_k}{\binom{n}{k} o_n} \lim_{\varepsilon \rightarrow 0} \lim_{t \rightarrow 0} \frac{1}{b_k \varepsilon^k} \int_{C_t^\varepsilon} h_{n-k}(x) dx &\leq \mu^{(n-k+1)}(f_{\mathbb{C}}) + \mu^{(n-k)}(f_{\mathbb{C}}). \end{aligned}$$

Furthermore,

$$\begin{aligned} \lim_{\varepsilon \rightarrow 0} \lim_{t \rightarrow 0} \int_{C_t^\varepsilon} s_0(x) dx &= - \frac{1}{g_{n+1, 2}} \int_{G_{n+1}^2} \text{deg}_0 \nabla(f|_K) dK + 1, \\ \lim_{\varepsilon \rightarrow 0} \lim_{t \rightarrow 0} \int_{C_t^\varepsilon} h_0(x) dx &\leq \mu^{(1)}(f_{\mathbb{C}}) + \mu^{(0)}(f_{\mathbb{C}}) = e(f_{\mathbb{C}}). \end{aligned}$$

Proof. Use Corollary 5.2, Theorem 5.3, Corollary 5.6, Theorem 5.7 and the results of Section 6. \square

Let us recall the main result we proved in [Du2]:

$$\begin{aligned} \frac{1}{g_{n+1, n}} \lim_{\varepsilon \rightarrow 0} \lim_{t \rightarrow 0} \int_{C_t^\varepsilon} s_n(x) dx &= - [\text{deg}_0 \nabla F + \text{sign}(t) \text{deg}_0 \bar{H}] \\ &+ \frac{1}{g_{n+1, n}} \int_{G_{n+1}^n} \text{deg}_0 \nabla(f|_K) dK, \end{aligned}$$

where the mappings F and \bar{H} are defined in the introduction. Using this, Theorem 7.1 and the formula for $\chi(C_t^\varepsilon)$ given in [Du2] Theorem 3.2, we obtain real versions of Kennedy's formula, that is to say Gauss–Bonnet type formulas for the real Milnor fibre.

Corollary 7.2. If n is even, then

$$\chi(C_t^\varepsilon) = \sum_{k=0}^{n/2} \frac{o_{2k}}{\binom{n}{2k} o_n} \lim_{\varepsilon \rightarrow 0} \lim_{t \rightarrow 0} \frac{1}{b_{2k} \varepsilon^{2k}} \int_{C_t^\varepsilon} s_{n-2k}(x) dx.$$

If n is odd, then

$$\chi(C_t^\varepsilon) = \frac{1}{2} \chi(C_0 \cap S_\varepsilon^n) = \sum_{k=0}^{\frac{n-1}{2}} \frac{o_{2k+1}}{\binom{n}{2k+1} o_n} \lim_{\varepsilon \rightarrow 0} \lim_{t \rightarrow 0} \frac{1}{b_{2k+1} \varepsilon^{2k+1}} \int_{C_t^\varepsilon} s_{n-2k-1}(x) dx.$$

Proof. Let us prove first the case n even. Theorem 3.2 in [Du2] states that

$$\chi(C_t^\varepsilon) = 1 - \text{deg}_0 \nabla F - \text{sign}(t) \text{deg}_0 \bar{H}.$$

We have

$$\begin{aligned} \frac{1}{g_{n+1,n}} \lim_{\varepsilon \rightarrow 0} \lim_{t \rightarrow 0} \int_{C_t^\varepsilon} s_n(x) dx &= - [\text{deg}_0 \nabla F + \text{sign}(t) \text{deg}_0 \bar{H}] \\ &\quad + \frac{1}{g_{n+1,n}} \int_{G_{n+1}^n} \text{deg}_0 \nabla(f|_K) dK. \end{aligned}$$

By Theorem 7.1, we know that for $k \in \{1, \dots, \frac{n-2}{2}\}$:

$$\begin{aligned} \frac{o_{2k}}{\binom{n}{2k} o_n} \lim_{\varepsilon \rightarrow 0} \lim_{t \rightarrow 0} \frac{1}{b_{2k} \varepsilon^{2k}} \int_{C_t^\varepsilon} s_{n-2k}(x) dx &= - \frac{1}{g_{n+1,n-2k+2}} \int_{G_{n+1}^{n-2k+2}} \text{deg}_0 \nabla(f|_K) dK \\ &\quad + \frac{1}{g_{n+1,n-2k}} \int_{G_{n+1}^{n-2k}} \text{deg}_0 \nabla(f|_H) dH, \end{aligned}$$

and that

$$\lim_{\varepsilon \rightarrow 0} \lim_{t \rightarrow 0} \int_{C_t^\varepsilon} s_0(x) dx = - \frac{1}{g_{n+1,2}} \int_{G_{n+1}^2} \text{deg}_0 \nabla(f|_K) dK + 1.$$

Adding these $\frac{n}{2} + 1$ equalities, we obtain that

$$\sum_{k=0}^{n/2} \frac{o_{2k}}{\binom{n}{2k} o_n} \lim_{\varepsilon \rightarrow 0} \lim_{t \rightarrow 0} \frac{1}{b_{2k} \varepsilon^{2k}} \int_{C_t^\varepsilon} s_{n-2k}(x) dx = 1 - [\text{deg}_0 \nabla F + \text{sign}(t) \text{deg}_0 \bar{H}].$$

The term in the right-hand side of this equality is $\chi(C_t^\varepsilon)$. If n is odd, Theorem 3.2 in [Du2] states that

$$\chi(C_t^\varepsilon) = 1 - \text{deg}_0 \nabla f.$$

By Theorem 7.1, we know that for $k \in \{0, \dots, \frac{n-3}{2}\}$:

$$\begin{aligned} \frac{o_{2k+1}}{\binom{n}{2k+1} o_n} \lim_{\varepsilon \rightarrow 0} \lim_{t \rightarrow 0} \frac{1}{b_{2k+1} \varepsilon^{2k+1}} \int_{C_t^\varepsilon} s_{n-2k-1}(x) dx \\ = - \frac{1}{g_{n+1,n-2k+1}} \int_{G_{n+1}^{n-2k+1}} \text{deg}_0 \nabla(f|_K) dK \\ + \frac{1}{g_{n+1,n-2k-1}} \int_{G_{n+1}^{n-2k-1}} \text{deg}_0 \nabla(f|_H) dH, \end{aligned}$$

and that

$$\lim_{\varepsilon \rightarrow 0} \lim_{t \rightarrow 0} \int_{C_t^\varepsilon} s_0(x) dx = - \frac{1}{g_{n+1,2}} \int_{G_{n+1}^2} \text{deg}_0 \nabla(f|_K) dK + 1.$$

Adding these $\frac{n+1}{2}$ equalities, we obtain that

$$\sum_{k=0}^{\frac{n-1}{2}} \frac{a_{2k+1}}{\binom{n}{2k+1} o_n} \lim_{\varepsilon \rightarrow 0} \lim_{t \rightarrow 0} \frac{1}{b_{2k+1} \varepsilon^{2k+1}} \int_{C_t^\varepsilon} s_{n-2k-1}(x) dx = 1 - \text{deg}_0 \nabla f.$$

The term in the right-hand side of this equality is $\chi(C_t^\varepsilon)$. Since C_t^ε is an odd-dimensional manifold with boundary, we have that $\chi(C_t^\varepsilon) = \frac{1}{2} \chi(C_t \cap S_\varepsilon^n)$. But C_0 intersects S_ε^n transversally if $0 < \varepsilon \ll 1$, hence $C_0 \cap S_\varepsilon^n$ is diffeomorphic to $C_t \cap S_\varepsilon^n$ for $0 < |t| \ll \varepsilon \ll 1$. This proves the third equality of the corollary. \square

We end this paper with two remarks. In [BB], the authors define spherical densities $\tilde{\Theta}_i(X, x)$, $i = 1, \dots, N - 1$, for a point x belonging to a definable set $X \subset \mathbb{R}^N$. They are generalizations of the classical density. Michel Coste asked the author about the relations between these densities and our limits of curvature integrals. Using the following formula ([Ar], [Wa]):

$$\chi(\{f \leq 0\} \cap S_\varepsilon^n) = 1 - \text{deg}_0 \nabla f \quad (= \frac{1}{2} \chi(\{f = 0\} \cap S_\varepsilon^n) \text{ if } n \text{ is odd}),$$

the spherical Gauss–Bonnet formula ([BB], Theorem 1.2, [Sa], p. 302–303) and the spherical kinematic formula ([BB], Theorem 4.4), it is possible to express the mean-values $\int_{G_{n+1}^k} \text{deg}_0 \nabla(f|_H) dH$ in terms of the $\tilde{\Theta}_i(\{f \leq 0\}, 0)$ and $\tilde{\Theta}_i(\{f = 0\}, 0)$. For example, if $n + 1 = 2$,

$$\int_{G_2^1} \text{deg}_0 \nabla(f|_H) dH = 2\pi \left(\frac{1}{2} - \tilde{\Theta}_2(\{f \leq 0\}, 0) \right),$$

and if $n + 1 = 3$,

$$\int_{G_3^2} \text{deg}_0 \nabla(f|_H) dH = 2\pi (1 - \tilde{\Theta}_2(\{f = 0\}, 0)).$$

This makes the link between the spherical densities and the limits of curvature integrals on the real Milnor fibre.

We have restricted ourselves to the case of a polynomial. Except for Bezout’s inequality, everything works in the analytic case. It is possible to prove Proposition 5.1 in the analytic case (even in the subanalytic case) using a more sophisticated argument based on the Thom–Mather first isotopy lemma as is done in [CGM] (see also [CY], p. 157). However the spirit of this paper is to apply techniques of integral geometry to singularity theory rather than to focus on the category of functions we work with. That is why we have chosen to present our results only in the algebraic case.

References

- [Ar] V. I. Arnold, Index of a singular point of a vector field, the Petrovski-Oleinik inequality, and mixed Hodge structures. *Funct. Anal. Appl.* **12** (1978), 1–14. [Zbl 0407.57025](#) [MR 0498592](#)
- [BB] A. Bernig, L. Bröcker, Courbures intrinsèques dans les catégories analytico-géométriques. *Ann. Inst. Fourier (Grenoble)* **53** (6) (2003), 1897–1924. [Zbl 1053.53053](#) [MR 2038783](#)
- [BCR] J. Bochnak, M. Coste, M. F. Roy, *Géométrie algébrique réelle*. *Ergeb. Math. Grenzgeb.* **12**, Springer-Verlag, 1987. [Zbl 0633.14016](#) [MR 0949442](#)
- [Co] G. Comte, Equisingularité réelle: nombres de Lelong et images polaires. *Ann. Sci. Ecole Norm. Sup* (4) **33** (6), (2000) 757–788. [Zbl 0981.32018](#) [MR 1832990](#)
- [CGM] G. Comte, P. Graftieaux, M. Merle, Equisingularité réelle: invariants locaux et conditions de régularité. Preprint.
- [CY] G. Comte, Y. Yomdin, *Tame geometry with application in smooth analysis*. *Lecture Notes in Math.* **1834**, Springer-Verlag, Berlin 2004. [Zbl 1076.14079](#) [MR 2041428](#)
- [Du1] N. Dutertre, Degree formulas for a topological invariant of bifurcations of function-germs. *Kodai Math. J.* **23** (3) (2000), 442–461. [Zbl 0982.58025](#) [MR 1787676](#)
- [Du2] N. Dutertre, Courbures et singularités réelles. *Comment. Math. Helv.* **77** (4) (2002), 846–863. [Zbl 1022.58017](#) [MR 1949116](#)
- [Fe] W. Fenchel, On total curvature of riemannian manifolds I. *J. London Math. Soc.* **15** (1940), 15–22. [Zbl 0026.26401](#) [MR 0002252](#)
- [Fu] T. Fukui, An algebraic formula for a topological invariant of bifurcation of 1-parameter family of function-germs. In *Stratifications, singularities, and differential equations, II* (Marseille, 1990; Honolulu, HI, 1990), *Travaux en cours* **55**, Hermann, Paris 1997, 45–54. [Zbl 0887.57037](#) [MR 1473240](#)
- [G-B.T] E. Garcia Barroso, B. Teissier, Concentration multi-échelles de courbure dans des fibres de Milnor. *Comment. Math. Helv.* **74** (3) (1999), 398–418. [Zbl 0956.32028](#) [MR 1710694](#)
- [Gr] P. A. Griffiths, Complex differential and integral geometry and curvature integrals associated to singularities of complex analytic varieties. *Duke Math. J.* **45** (3) (1978) 427–512. [Zbl 0409.53048](#) [MR 0507455](#)
- [KR] K. Kurdyka, G. Raby, Densité des ensembles sous-analytiques. *Ann. Inst. Fourier (Grenoble)* **39** (3) (1989) 753–771. [Zbl 0673.32015](#) [MR 1030848](#)
- [Ke] G. Kennedy, Griffiths' integral formula for the Milnor number. *Duke Math. J.* **48** (1) (1981), 159–165. [Zbl 0467.32006](#) [MR 0610181](#)
- [La1] R. Langevin, Courbure et singularités complexes. *Comment. Math. Helv.* **54** (1) (1979), 6–16. [Zbl 0429.32008](#) [MR 0522029](#)
- [La2] R. Langevin, Classe moyenne d'une sous-variété d'une sphère ou d'un espace projectif. *Rend. Circ. Mat. Palermo* (2) **28** (2) (1979), 313–318. [Zbl 0459.53048](#) [MR 0580266](#)
- [La3] R. Langevin, Courbures, feuilletages et surfaces. Dissertation, Université Paris-Sud, Orsay 1980; Publications Mathématiques d'Orsay **80**, 3, Université de Paris-Sud, Département de Mathématiques, Orsay 1980. [Zbl 0466.53036](#) [MR 0584793](#)

- [LL] R. Langevin, D. T. Lê, Courbure au voisinage d'une singularité. *C. R. Acad. Sci. Paris Sér. A-B* **290** (2) (1980), 95–98. [Zbl 0429.32009](#) [MR 0563947](#)
- [LR] R. Langevin, H. Rosenberg, Fenchel types theorems for submanifolds of S^n . *Comment. Math. Helv.* **71** (4) (1996), 594–616. [Zbl 0880.53047](#) [MR 1420512](#)
- [LS] R. Langevin, T. Shifrin, Polar varieties and integral geometry. *Amer. J. Math.* **104** (3) (1982), 553–605. [Zbl 0504.53048](#) [MR 0658546](#)
- [Lo] F. Loeser, Formules intégrales pour certains invariants locaux des espaces analytiques complexes. *Comment. Math. Helv.* **59** (2) (1984), 204–225. [Zbl 0579.32009](#) [MR 0749105](#)
- [MA] J. N. Mather, Generic projections. *Ann. of Math. (2)* **98** (1978), 226–245. [Zbl 0242.58001](#) [MR 0362393](#)
- [Mi] J. Milnor, *Singular points of complex hypersurfaces*. Ann. Math. Stud. 61, Princeton University Press, Princeton, NJ, 1968. [Zbl 0184.48405](#) [MR 0239612](#)
- [Ne] L. Ness, Curvature on algebraic plane curves I. *Compositio Math.* **35** (1) (1977), 57–63. [Zbl 0369.32003](#) [MR 0453752](#)
- [Ri] J.-J. Risler, On the curvature of the Milnor fiber. *Bull. London Math. Soc.* **35** (4) (2003), 445–454. [Zbl 1030.32024](#) [MR 1978997](#)
- [Sa] L. A. Santaló, *Integral geometry and geometric probability*. Encyclopedia of Mathematics and its Applications, Vol 1. Addison-Wesley Publishing Co., Reading, Mass. 1976. [Zbl 0342.53049](#) [MR 0433364](#)
- [ST] D. Siersma, M. Tibar, The Gauss-Bonnet defect of complex affine hypersurfaces. *Bull. Sci. Math.* **130** (2) (2006), 110–122. [Zbl 1093.53080](#) [MR 2200641](#)
- [SI] V. V. Slavskii, Integral relations with an orthogonal projection for hypersurfaces. *Siberian Math. J.* **16** (1) (1975), 82–98. [Zbl 0314.53037](#) [MR 0375191](#)
- [Te1] B. Teissier, Cycles évanescents, sections planes et conditions de Whitney. In *Singularités à Cargèse, 1972, Astérisque* **7–8** (1973), 285–362. [Zbl 0295.14003](#) [MR 0374482](#)
- [Te2] B. Teissier, Introduction to equisingularity problems. In *Algebraic geometry* (Arcata 1974), Proc. Sympos. Pure Math. 29, Amer. Math. Soc., Providence, R.I., 1975, 593–632. [Zbl 0322.14008](#) [MR 0422256](#)
- [Va] N. A. Varchenko, The integrality of the limit of the integral of the curvature along the boundary of an isolated singularity of a surface in \mathbb{C}^3 . *Russian Math. Surveys* **33** (6) (1978), 263–264. [Zbl 0473.57022](#) [MR 0526016](#)
- [Wa] C. T. C. Wall, Topological invariance of the Milnor number mod 2. *Topology* **22** (1983), 345–350. [Zbl 0516.58010](#) [MR 0710107](#)

Received March 2, 2005; revised November 17, 2005

Nicolas Dutertre, Université de Provence, Centre de Mathématiques et Informatique, 39 rue Joliot-Curie, 13453 Marseille Cedex 13, France

E-mail: dutertre@cmi.univ-mrs.fr