

The virtual fibering theorem for 3-manifolds

Stefan FRIEDL and Takahiro KITAYAMA*

Abstract. In 2007 Agol showed that if N is an aspherical compact 3-manifold with empty or toroidal boundary such that $\pi_1(N)$ is virtually RFRS, then N is virtually fibered. We give a largely self-contained proof of Agol's theorem using complexities of sutured manifolds.

Mathematics Subject Classification (2010). 57M05, 57M10.

Keywords. Fibered 3-manifolds, RFRS groups.

1. Introduction

In 1982 Thurston [Th82], Question 18, asked whether every hyperbolic 3-manifold is virtually fibered, i.e. whether every hyperbolic 3-manifold admits a finite cover which fibers over S^1 .

Evidence towards an affirmative answer was given by many authors, including Agol, Boyer, and Zhang [ABZ08], Aitchison and Rubinstein [AR99], Button [Bu05], DeBlois [DeB10], Gabai [Ga86], Guo and Zhang [GZ09], Leininger [Lei02], Reid [Re95], and Walsh [Wa05].

The first general virtual fibering theorem was proved by Agol in 2007. In order to state the theorem we need two more definitions.

- (1) A group π is *residually finite rationally solvable* or *RFRS* if π admits a filtration

$$\pi = \pi_0 \supset \pi_1 \supset \pi_2 \dots$$

such that the following hold:

- (a) $\bigcap_k \pi_k = \{1\}$;
- (b) for any k the group π_k is a normal, finite index subgroup of π ;

*This work was supported by Grant-in-Aid for JSPS Fellows.

(c) for any k the map

$$\pi_k \longrightarrow \pi_k / \pi_{k+1}$$

factors through

$$\pi_k \longrightarrow H_1(\pi_k; \mathbb{Z}) / \text{torsion}.$$

(2) Given a 3-manifold N , we say

$$\phi \in H^1(N; \mathbb{Q}) = \text{Hom}(\pi_1(N), \mathbb{Q})$$

is *fibred* if there exists an $n \in \mathbb{N}$ and a locally trivial fiber bundle $p: N \rightarrow S^1$ such that

$$\phi = \frac{1}{n} \cdot p_*: \pi_1(N) \longrightarrow \mathbb{Q}.$$

We can now state Agol's theorem; see [Ag08], Theorem 5.1.

Theorem 1.1 (Agol [Ag08]). *Let N be an irreducible 3-manifold with empty or toroidal boundary such that $\pi_1(N)$ is virtually RFRS. Let $\phi \in H^1(N; \mathbb{Q})$ be non-trivial. Then there exists a finite cover*

$$q: \tilde{N} \longrightarrow N$$

such that q^ϕ is the limit of a sequence of fibred classes in $H^1(\tilde{N}; \mathbb{Q})$.*

The key idea in the proof of the theorem is that the RFRS condition ensures that given a Thurston norm minimizing surface one can find ‘enough’ surfaces in finite covers to ‘reduce the complexity of the guts’ by perturbing the initial surface appropriately. Agol uses the theory of ‘least-weight taut normal surfaces’ introduced and developed by Oertel [Oe86] and Tollefson and Wang [TW96] to carry through this program.

In the introduction to [Ag08] Agol writes that ‘the natural setting [...] lies in sutured manifold hierarchies’. We pick up this suggestion and provide a proof of Theorem 1.1 using sutured manifolds and their hierarchies. In our proof we only use standard results about the Thurston norm and sutured manifold decompositions (see [Th86] and [Ga83]) and a complexity for sutured manifolds defined by Gabai [Ga83]. At the core our argument also follows the above ‘key idea’, but for the most part the treatment of the argument is somewhat different from Agol's original proof.

In a stunning turn of events it has been shown over the last few years that most 3-manifold groups are in fact virtually RFRS. More precisely, the following theorem was proved by Agol [Ag13] and Wise [Wi12] in the hyperbolic case and by Przytycki and Wise [PW12] in the case of a 3-manifold with a non-trivial JSJ decomposition.

Theorem 1.2 (Agol [Ag13], Przytycki and Wise [PW12], Wise [Wi12]). *If N is an irreducible 3-manifold with empty or toroidal boundary which is not a graph manifold, then $\pi_1(N)$ is virtually RFRS.*

Furthermore it follows from work of Liu [Li11] and Przytycki and Wise [PW11] that the fundamental group of a graph manifold with boundary is also virtually RFRS. Finally Liu [Li11] showed that the fundamental group of a closed aspherical graph manifold is virtually RFRS if and only if N is non-positively curved, i.e. if it admits a Riemannian metric of non-positive curvature. Combining these results with Theorem 1.1 we thus obtain the following result.

Theorem 1.3. *Let N be an irreducible 3-manifold with empty or toroidal boundary and let $\phi \in H^1(N; \mathbb{Q})$ be non-trivial. Suppose one of the following two conditions hold:*

- (1) N is not a closed graph manifold, or
- (2) N is a closed graph manifold which is non-positively curved,

then there exists a finite cover $q: \tilde{N} \rightarrow N$ such that q^ϕ is the limit of a sequence of fibered classes in $H^1(\tilde{N}; \mathbb{Q})$.*

Remark. (1) If $\pi_1(N)$ is infinite and virtually RFRS, then there exists a finite cover with positive first Betti number. It therefore follows from Theorem 1.3 that if N is an irreducible 3-manifold with empty or toroidal boundary which is not a graph manifold, then N is virtually fibered. In particular Theorem 1.3 gives an affirmative answer to Thurston's question.

(2) The work of Agol [Ag13], Przytycki and Wise [PW12], and Wise [Wi12] resolves not only Thurston's Virtual Fibering Conjecture but also has a long list of other consequences. We refer to the survey paper [AFW12] for a comprehensive discussion.

(3) Let N be an aspherical 3-manifold. If N is not a closed graph manifold, then it follows from work of Leeb [Leb95] (see also [Br99] and [Br01]) that N is non-positively curved. Combining this with the above results we see that an aspherical 3-manifold N is non-positively curved if and only if $\pi_1(N)$ is virtually RFRS.

(4) There are graph manifolds which are virtually fibered but whose fundamental groups are not virtually RFRS. One class of such graph manifolds is given by Sol-manifolds (see e.g. [Ag13] and [AFW12]).

(5) It follows from classical arguments that the conclusion of Theorem 1.3 in fact holds for any virtually fibered graph manifold.

(6) The conclusion that any cohomology class can be approximated by fibered classes in a suitable finite cover has been crucial in the applications to twisted Alexander polynomials and to the study of surfaces of minimal complexity in 4-manifolds with a free S^1 -action (see [FV12] and [FV14]).

For completeness' sake we also mention Agol's result on finite covers of taut sutured manifolds, even though it plays no role in the later part of the paper. Using the argument in the proof of Theorem 1.1 and using a 'doubling' argument Agol proves that given any taut sutured manifold with virtually RFRS fundamental group there exists a finite cover which admits a depth one taut oriented foliation. (We will not define these notions and we refer instead to [Ga83], [Ag08], and [CC03] for background information and precise definitions.) More precisely, Agol [Ag08], Theorem 6.1, proved the following result.

Theorem 1.4 (Agol [Ag08]). *Let (N, γ) be a taut sutured manifold such that $\pi_1(N)$ is virtually RFRS. Then there exists a finite covering $p: (\tilde{N}, \tilde{\gamma}) \rightarrow (N, \gamma)$ such that $(\tilde{N}, \tilde{\gamma})$ admits a depth one taut oriented foliation.*

In the above discussion we already saw that the fundamental group of any irreducible 3-manifold with non-trivial toroidal boundary is virtually RFRS. A straightforward doubling argument (see e.g. [AFW12], Section 5.3) shows that in fact the fundamental group of any irreducible 3-manifold with non-empty incompressible boundary is virtually RFRS. Combining this observation with Theorem 1.4 we obtain the following theorem.

Theorem 1.5. *Let (N, γ) be a taut-sutured manifold. Then there exists a finite covering $p: (\tilde{N}, \tilde{\gamma}) \rightarrow (N, \gamma)$ such that $(\tilde{N}, \tilde{\gamma})$ admits a depth one taut-oriented foliation.*

The paper is organized as follows. In Sections 2 and 3 we recall some standard facts about the Thurston norm and sutured manifolds. Along the way we will also make some preparations for the proof of Proposition 4.1. This proposition allows us to carefully arrange surfaces to 'cut the guts' of a given surface. This result is the technical heart of the paper and we give a very detailed proof of it. In Proposition 4.2 we then summarize the effect of 'cutting by a surface' on the complexities of the guts of a given surface. Finally in the last section we present our proof of Theorem 1.1.

Convention. All manifolds are assumed to be compact and oriented. We do not assume that spaces are connected, nonetheless, if we talk about the fundamental group of a space without specifying a base point, then we implicitly assume that the space is connected. All surfaces in a 3-manifold are assumed to be properly embedded, unless we say explicitly otherwise. If N is a 3-manifold and $R \subset N$ a properly embedded surface and $a > 0$, then we denote by $R \times [-a, a]$ a neighborhood of R such that $(R \times [-a, a]) \cap \partial N = \partial R \times [-a, a]$. Finally, given a submanifold $S \subset M$ we denote by νS an open tubular neighborhood around S .

Acknowledgment. We wish to thank Ian Agol and Steve Boyer for helpful conversations. We are also grateful to the referee for many helpful comments. Finally, we are especially indebted to András Juhász for pointing out a mistake in our first version of this paper.

2. The Thurston norm

2.1. The Thurston norm and fibered classes. Let S be a surface with connected components $S_1 \cup \cdots \cup S_k$. We then refer to

$$\chi_-(S) := \sum_{i=1}^k \max\{-\chi(S_i), 0\}$$

as the *complexity* of S . Now let N be a 3-manifold and let $\phi \in H^1(N; \mathbb{Z})$. It is well-known that any class in $H^1(N; \mathbb{Z})$ is dual to a properly embedded surface. The *Thurston norm of ϕ* is defined as

$$x_N(\phi) := \min\{\chi_-(S) \mid S \subset N \text{ properly embedded and dual to } \phi\}.$$

We will drop the subscript ‘ N ’, when the manifold N is understood.

Thurston [Th86] showed that x is a seminorm on $H^1(N; \mathbb{Z})$, which implies that x can be extended to a seminorm on $H^1(N; \mathbb{Q})$. We denote the seminorm on $H^1(N; \mathbb{Q})$ also by x . Throughout the paper we will freely go back and forth between $H^1(N; \mathbb{Q})$ and $H_2(N, \partial N; \mathbb{Q})$. In particular we will consider the Thurston norm also for classes in $H_2(N, \partial N; \mathbb{Q})$.

Thurston furthermore proved that the Thurston norm ball

$$B(N) := \{\phi \in H^1(N; \mathbb{Q}) \mid x(\phi) \leq 1\}$$

is a (possibly non-compact) finite convex polytope. A *Thurston cone of N* is defined to be either an open cone $\{rf \mid r > 0, f \in F\}$ on a face F of $B(N)$ or a maximal connected subset of $H^1(N; \mathbb{Q}) \setminus \{0\}$ on which x vanishes. The Thurston cones have the following properties:

(1) if ϕ, ψ lie in a Thurston cone C , then $\phi + \psi \in C$ and given any $r > 0$ we have $r\phi \in C$;

(2) the Thurston cones are disjoint and their union equals $H^1(N; \mathbb{Q}) \setminus \{0\}$;

(3) the Thurston norm is additive precisely on the closures of Thurston cones, i.e. given $\phi, \psi \in H^1(N; \mathbb{Q})$ we have

$$x(\phi + \psi) = x(\phi) + x(\psi) \iff \text{there exists a Thurston cone } C \text{ with } \phi, \psi \in \bar{C}.$$

In the following we say that an integral class $\phi \in H^1(N; \mathbb{Z}) = \text{Hom}(\pi_1(N), \mathbb{Z})$ is *fibred* if there exists a fibration $p: N \rightarrow S^1$ such that

$$\phi = p_*: \pi_1(N) \longrightarrow \mathbb{Z}.$$

We say $\phi \in H^1(N; \mathbb{Q})$ is *fibred* if a non-trivial integral multiple of ϕ is fibred. Thurston [Th86] showed that the set of fibred classes equals the union of some top-dimensional Thurston cones. These cones are referred to as the *fibred cones* of N .

2.2. Subordination. Given two non-zero cohomology classes $\phi, \psi \in H^1(N; \mathbb{Q})$ we say ϕ is *subordinate* to ψ if $\phi \in \overline{C}$ where C is the unique Thurston cone which contains ψ . We collect several properties of subordination in a lemma.

Lemma 2.1. (1) *Subordination is transitive, i.e. if ϕ is subordinate to ψ and ψ is subordinate to φ , then ϕ is subordinate to φ .*

(2) *Given any two non-zero cohomology classes $\phi, \psi \in H^1(N; \mathbb{Q})$ there exists an $m \in \mathbb{N}$ such that ϕ is subordinate to $m\phi + \psi$.*

(3) *If ϕ is subordinate to $m\phi + \psi$ for some m , then ϕ is also subordinate to $k\phi + \psi$ for any $k \geq m$.*

(4) *Let $p: \tilde{N} \rightarrow N$ be a finite cover and let $\phi, \psi \in H^1(N; \mathbb{Q})$ be two non-zero cohomology classes. Then ϕ is subordinate to ψ if and only if $p^*\phi$ is subordinate to $p^*\psi$.*

The first three statements are straightforward to verify. The last statement is an immediate consequence of the fact that given any cover $p: \tilde{N} \rightarrow N$ of degree k and any $\phi \in H^1(N; \mathbb{Q})$ we have $x(p^*\phi) = k \cdot x(\phi)$ (see [Ga83], Corollary 6.13). Put differently, $p^*: H^1(N; \mathbb{Q}) \rightarrow H^1(\tilde{N}; \mathbb{Q})$ is up to the scaling factor k an isometry of vector spaces.

3. Complexities for sutured manifolds

3.1. Sutured manifolds. A sutured manifold (M, R_-, R_+, γ) consists of a 3-manifold M together with a decomposition of its boundary

$$\partial M = -R_- \cup \gamma \cup R_+$$

into oriented submanifolds where the following conditions hold:

- (1) γ is a disjoint union of annuli.
- (2) R_- and R_+ are disjoint.
- (3) If A is a component of γ , then $R_- \cap A$ is a boundary component of A and of R_- , and similarly for $R_+ \cap A$. Furthermore, $[R_+ \cap A] = [R_- \cap A] \in H_1(A; \mathbb{Z})$ where we endow $R_{\pm} \cap A$ with the orientation coming from the boundary of R_{\pm} .

(Here we give ∂M the orientation such that R_+ are precisely those components of $\overline{\partial M \setminus \gamma}$ whose normal vectors point out of M .)

We sometimes just write (M, γ) instead of (M, R_-, R_+, γ) , but it is important to remember that R_- and R_+ are part of the structure of a sutured manifold.

Finally a simple example of a sutured manifold is given as follows: Let R be a surface, then

$$(R \times [-1, 1], R \times -1, R \times 1, \partial R \times [-1, 1])$$

is a sutured manifold. We refer to such a sutured manifold as a *product sutured manifold*.

3.2. Taut sutured manifolds and Thurston norm minimizing surfaces. A sutured manifold (M, R_-, R_+, γ) is called *taut* if M is irreducible and if R_- and R_+ have minimal complexity among all surfaces representing $[R_-] = [R_+] \in H_2(M, \gamma; \mathbb{Z})$.

Let R be a surface in a closed 3-manifold N . We say that R is *good* if R has no spherical components and no component which bounds a solid torus. Furthermore we say R is *Thurston norm minimizing* if R has minimal complexity in its homology class $[R] \in H_2(N, \partial N; \mathbb{Z})$. It is clear that any homology class can be represented by a good Thurston norm minimizing surface.

Note that if R is a good Thurston norm minimizing surface in an irreducible 3-manifold, then a standard argument using the Loop Theorem (see [He76], Chapter 4) shows that R is also π_1 -injective.

To a surface R in a closed 3-manifold N we now associate the sutured manifold

$$N(R) = (N \setminus R \times (-1, 1), R \times 1, R \times -1, \emptyset).$$

We conclude this section with the following two observations regarding $N(R)$.

- (1) If N is irreducible and if R is a Thurston norm minimizing surface without spherical components, then $N(R)$ is a taut sutured manifold.
- (2) The surface R is a fiber of a fibration $N \rightarrow S^1$ if and only if $N(R)$ is a product sutured manifold.

3.3. Sutured manifold decompositions. We now recall the definition of a sutured manifold decomposition which also goes back to Gabai [Ga83]. Let (M, R_-, R_+, γ) be a sutured manifold. We say that a properly embedded surface S is a *decomposition surface* if the following condition holds: for any component A of γ every component of $A \cap S$ is either a non-separating arc in A , or it is a closed curve which is homologous to $[A \cap R_-] = [A \cap R_+] \in H_1(A; \mathbb{Z})$.

Let S be a decomposition surface of (M, R_-, R_+, γ) . Gabai ([Ga83], Definition 3.1) defines the sutured manifold decomposition

$$(M, R_-, R_+, \gamma) \overset{S}{\rightsquigarrow} (M', R'_-, R'_+, \gamma')$$

where

$$\begin{aligned} M' &= M \setminus S \times (-1, 1), \\ \gamma' &= (\gamma \cap M') \cup \overline{\nu(S'_+ \cap R_-)} \cup \overline{\nu(S'_- \cap R_+)}, \\ R'_+ &= ((R_+ \cap M') \cup S'_+) \setminus \text{int } \gamma' \\ R'_- &= ((R_- \cap M') \cup S'_-) \setminus \text{int } \gamma'. \end{aligned}$$

Here S'_+ (resp. S'_-) is the union of the components of $(S \times -1 \cup S \times 1) \cap M'$ whose normal vector points out of (resp. into) M' . Furthermore, by $\nu(S'_\pm \cap R_\mp)$ we mean an open tubular neighborhood of $S'_\pm \cap R_\mp$ in ∂M . We say that a decomposition surface S is *taut* if all the components of the sutured manifold decomposition along S are taut.

We make the following observations.

- (1) If $\gamma = \emptyset$, then any surface in M is a decomposition surface for (M, γ) .
- (2) If each component of S is a π_1 -injective surface, then for any component of M' the inclusion into M induces a monomorphism of fundamental groups.
- (3) If N is a closed 3-manifold and if $R \subset N$ is a closed surface, then R is a decomposition surface for the sutured manifold $(N, \emptyset, \emptyset, \emptyset)$, and $N(R)$ is precisely the result of the decomposition along R .
- (4) If (M, γ) is a sutured manifold and if $S \subset M$ is a decomposition surface which is boundary parallel, then the resulting sutured manifolds (M', γ') is a union of product sutured manifolds and a sutured manifold (M'_0, γ'_0) which is canonically diffeomorphic to (M, γ) .

3.4. Guts of a sutured manifold. Let (M, R_-, R_+, γ) be a taut sutured manifold. An *admissible annulus* is an annulus S in M which does not cobound a solid cylinder in M and such that one boundary component of S lies on R_- and the other one lies on R_+ . Furthermore, an *admissible disk* is a disk S in M such that $S \cap R_-$ and $S \cap R_+$ consist of an interval each.

We have the following elementary but very useful lemma (cf. [Ga83], Lemma 3.12).

Lemma 3.1. *Let (M, R_-, R_+, γ) be a taut sutured manifold. Then any admissible annulus and any admissible disk is a taut decomposition surface.*

An *admissible decomposition surface* for a sutured manifold (M, R_-, R_+, γ) is a disjoint union of admissible annuli and disks in (M, R_-, R_+, γ) . Given such an S we can perform the sutured manifold decomposition

$$(M, R_-, R_+, \gamma) \xrightarrow{\mathcal{S}} (M', R'_-, R'_+, \gamma').$$

We refer to any component of M' which is a product sutured manifold as a *window* of (M, R_-, R_+, γ) and we refer to any component of M' which is not a product sutured manifold as a *gut* of (M, R_-, R_+, γ) . Note that the definition of window and gut depends on the choice of the admissible decomposition surface. Nonetheless, from the context it is usually clear what admissible decomposition surface we are working with and we will therefore leave the dependence on S unmentioned.

Lemma 3.2. *Let (M, R_-, R_+, γ) be a sutured manifold such that M is irreducible. We pick an admissible decomposition surface. Then the following hold.*

- (1) *The guts and windows are π_1 -injective submanifolds of M .*
- (2) *The fundamental group of a gut is non-trivial.*
- (3) *If (M, R_-, R_+, γ) is taut, then the windows and guts are also taut.*

The first statement follows from the observation that the components of an admissible decomposition surface are π_1 -injective if M is irreducible, the second statement is a consequence of the irreducibility of M (or alternatively of the Poincaré conjecture) and the third statement is a consequence of Lemma 3.1.

We conclude this section with the following proposition.

Proposition 3.3. *Let (M, R_-, R_+, γ) be a taut sutured manifold and let*

$$p: (\tilde{M}, \tilde{\gamma}) \longrightarrow (M, \gamma)$$

be a finite cover.

- (1) *If (M, γ) is taut, then $(\tilde{M}, \tilde{\gamma})$ is also taut.*
- (2) *If $S \subset M$ is an admissible decomposition surface, then $p^{-1}(S)$ is an admissible decomposition surface for \tilde{M} , and the windows and guts of $(\tilde{M}, \tilde{\gamma})$ are precisely the preimages of the windows and guts of (M, γ) .*

Proof. Let (M, R_-, R_+, γ) be a taut sutured manifold and let $p: (\tilde{M}, \tilde{\gamma}) \rightarrow (M, \gamma)$ be a finite cover.

We first suppose that (M, γ) is taut. It follows from the Equivariant Sphere Theorem, see [MSY82], p. 647, and work of Gabai (e.g. by combining Corollaries 5.3 and 6.13 and Lemma 6.14 of [Ga83] with Corollary 2 of [Th86], that $(\tilde{M}, \tilde{\gamma})$ is also taut.

Now let $S \subset M$ be an admissible decomposition surface. Let $G = (G, S_-, S_+)$ be a gut of M and let $\tilde{G} = (\tilde{G}, \tilde{S}_-, \tilde{S}_+)$ be a component of $p^{-1}(G)$. We have to show that $\tilde{G} = (\tilde{G}, \tilde{S}_-, \tilde{S}_+)$ is not a product sutured

manifold. Since $G = (G, S_-, S_+)$ is not a product sutured manifold it follows from [He76], Theorem 10.5, that precisely one of the following two cases can occur:

(1) G is the twisted I -bundle over a Klein bottle and $S_- = \partial G$

or

(2) $\pi_1(S_-)$ has infinite index in $\pi_1(G)$.

We now consider these two cases separately.

(1) If $G = (G, S_-, S_+)$ is a twisted I -bundle over a Klein bottle with $S_- = \partial G$ and $S_+ = \emptyset$, then $\tilde{G} = (\tilde{G}, \tilde{S}_-, \tilde{S}_+)$ is a sutured manifold with $\tilde{S}_+ = \emptyset$, i.e. \tilde{G} is not a product sutured manifold.

(2) If $\pi_1(S_-)$ has infinite index in $\pi_1(G)$, then $\pi_1(\tilde{S}_-)$ also has infinite index in $\pi_1(\tilde{G})$, which implies that $(\tilde{G}, \tilde{S}_-, \tilde{S}_+)$ is not a product sutured manifold. \square

3.5. The double-curve sum of surfaces. Let N be a closed 3-manifold and let R and F be two embedded surfaces which are in general position. Note that by the standard ‘cut and paste’ technique applied to the intersection curves of R and F we can turn the immersed surface $R \cup F$ into an embedded surface $R \natural F$. The surface $R \natural F$ is sometimes called the double-curve sum of R and F . Note that $R \natural F$ represents the same homology class as $R \cup F$ and that furthermore $R \natural F$ has the same complexity as $R \cup F$.

Now let R and F be two properly embedded surfaces in N in general position.

(1) A *filling ball* for (R, F) is an embedded ball $B \subset N$ such that $\partial B \subset R \cup F$ as oriented surfaces.

(2) A *filling solid torus* for (R, F) is an embedded solid torus $X \subset N$ such that $\partial X \subset R \cup F$ as oriented surfaces.

(Here we view B and X as oriented manifolds where the orientation does not necessarily have to agree with the orientation of N .) We then say that R and F form a *good pair* if there are no filling balls and no filling solid tori for (R, F) .

We will later on make use of the following elementary lemma.

Lemma 3.4. *Let N be a closed irreducible 3-manifold and let R and F be a good pair of embedded surfaces in N . Then the following hold:*

(1) R and F are good;

(2) $R \natural F$ is good;

(3) $F \cap N(R)$ is a decomposition surface for $N(R)$;

- (4) *there exist decomposition annuli C_1, \dots, C_k which are in one-to-one correspondence with the components of $R \cap F$ such that the following diagram commutes:*

$$\begin{array}{ccc}
 N & \xrightarrow{R} & N(R) \\
 \left. \begin{array}{c} R \uplus F \\ \downarrow \end{array} \right\} & & \left. \begin{array}{c} F \cap N(R) \\ \downarrow \end{array} \right\} \\
 N(R \uplus F) & \xrightarrow{C_1 \cup \dots \cup C_k} & (M, \gamma).
 \end{array}$$

A schematic illustration for $R \uplus F$ and the decomposition annuli C_i is given in Figure 1.

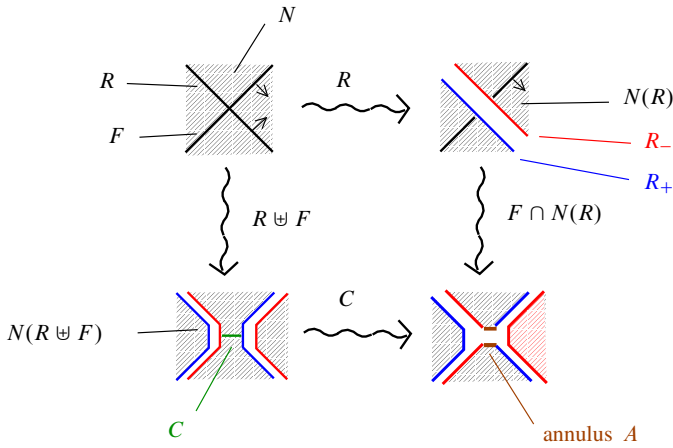

FIGURE 1
Schematic picture for decomposing along R and F

3.6. Complexity of sutured manifolds. Gabai [Ga83], Definition 4.11, associates to each connected sutured manifold (M, R_-, R_+, γ) an invariant $c(M, R_-, R_+, \gamma) \in \mathcal{O}$ which we refer to as the *complexity* of (M, R_-, R_+, γ) . Here \mathcal{O} is a totally ordered set with the property that any strictly descending chain in \mathcal{O} starting at a given element is finite. We denote the minimal element of \mathcal{O} by 0. We refer to [Ga83], Definition 4.3, for details¹.

Gabai [Ga83], Section 4, proved the following theorem.

Theorem 3.5. *Let (M, γ) be a connected sutured manifold and let*

$$(M, \gamma) \xrightarrow{S} (M', \gamma')$$

¹Note that our notation and name differ from [Ga83]: Gabai denotes this invariant $\overline{C}(M, R_-, R_+, \gamma)$ and calls it the ‘reduced complexity’.

be a sutured manifold decomposition along a connected decomposition surface S . Suppose that (M, γ) and (M', γ') are taut. Let (M'_0, γ'_0) be a component of (M', γ') . Then

$$c(M'_0, \gamma'_0) \leq c(M, \gamma).$$

Furthermore, if S is not boundary parallel, e.g. if $[S]$ is non-trivial in $H_2(M, \partial M; \mathbb{Z})$, then

$$c(M'_0, \gamma'_0) < c(M, \gamma).$$

Remark. (1) We could use the complexity $\hat{C}(M, R_-, R_+, \gamma)$ introduced by Scharlemann [Sc89], Definition 4.12. It follows from [Sc89], Definition 4.12, Remark 4.13(b), and Theorem 4.17, that the conclusion of Theorem 3.5 holds in an analogous way for Scharlemann's complexity.

(2) Juhász [Ju06] and [Ju08] defines and studies in detail the ‘sutured Floer homology $SFH(M, \gamma)$ ’ for ‘balanced’ sutured manifolds. The total rank of $SFH(M, \gamma)$ is a very useful complexity for balanced sutured manifolds and it has properties similar to Theorem 3.5. It would be interesting to give another proof of Theorem 5.1 using $SFH(M, \gamma)$. This though would require some adjustments since not all sutured manifolds which occur in our proof are balanced (e.g. if (M, R_-, R_+, γ) is balanced, then R_- and R_+ have no closed components).

4. Perturbations of homology classes

The key to proving the Virtual Fibration Theorem is to show that given a good Thurston norm minimizing surface R and a homology class $\psi \in H_2(N; \mathbb{Z})$ one can find a surface F such that given any gut or window X of $N(R)$ the intersection $F \cap X$ is a taut decomposition surface for X which represents the same class as the restriction of ψ to $H_2(X, \partial X; \mathbb{Z})$.

We start out with the following proposition.

Proposition 4.1. *Let N be a closed irreducible connected 3-manifold and let R be a good Thurston norm minimizing surface. Then for any choice of admissible decomposition surface for $N \setminus R \times (-4, 4)$ and any choice of $\psi \in H_2(N; \mathbb{Z})$ there exists an $m \in \mathbb{N}$ and a surface F with the following properties:*

- (W1) $[R]$ is subordinate to $m[R] + \psi$ and F represents $m[R] + \psi$;
- (W2) $F \uplus (R \times -3 \cup R \times 3)$ is Thurston norm minimizing;
- (W3) the intersections $F \cap R \times [-4, -2]$ and $F \cap R \times [2, 4]$ are product surfaces;
- (W4) if X is a gut or a window of $N \setminus R \times (-4, 4)$, then $F \cap X$ is a decomposition surface;

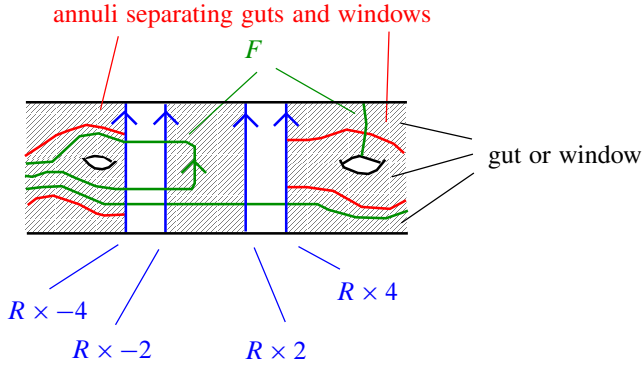

FIGURE 2
Schematic picture for Proposition 4.1

(W5) F and $R \times -3 \cup R \times 3$ are a good pair.

In the proposition we implicitly identified a tubular neighborhood of R in N with $R \times [-4, 4]$. Strictly speaking we should write $R \times \{-3\}$ and $R \times \{3\}$, but in our opinion $F \natural (R \times \{-3\} \cup R \times \{3\})$ is less readable than $F \natural (R \times -3 \cup R \times 3)$.

This proposition is the technical heart of our proof of the Virtual Fibering Theorem and we therefore give a detailed proof of the proposition. A very schematic picture for Proposition 4.1 is given in Figure 2.

Proof. Let N be a closed irreducible 3-manifold and let R be a good Thurston norm minimizing surface. We pick a tubular neighborhood $R \times [-5, 5]$ for R . We write $M = N \setminus R \times (-1, 1)$ which we view as a sutured manifold (M, γ) in the usual way.

We pick an admissible decomposition surface for M . We denote by

$$(M_i, R_{i+}, R_{i-}, \gamma_i), \quad i = 1, \dots, r$$

the corresponding guts and windows of M . Finally we denote by A_1, \dots, A_s the collection of all the components of the γ_i . Note that we can and will assume that for each A_i the intersection with $R \times [-5, -1]$ and $R \times [1, 5]$ consists of a union of product annuli.

Before we state the first claim of the proof we need to introduce one more definition. Let S be a surface and let c be a component of $S \cap A_i$ which is a closed curve. We pick a j such that A_i is a component of γ_j , i.e. such that A_i lies on ∂M_j . Note that c is a component of $\partial(S \cap M_j)$ and it thus inherits an orientation. We now say that c is *positive* if

$$[c] = [R_{j\pm} \cap A_i] \in H_1(A_i; \mathbb{Z})$$

and we say c is *negative* if

$$[c] = -[R_{j\pm} \cap A_i].$$

It is straightforward to see that if we chose the other M_k for which A_i is a component of γ_k , then the orientation of c flips and $[R_{k\pm} \cap A_i] = -[R_{j\pm} \cap A_i]$, which implies that we would get the same sign.

We can now formulate our first claim.

Claim. *Let $\psi \in H_2(N; \mathbb{Z})$. There exists an $l \in \mathbb{N}$ and a surface D with the following properties:*

- (D1) $[R]$ is subordinate to $l[R] + \psi$ and D represents $l[R] + \psi$;
- (D2) for any set of real numbers $-5 < x_1 < x_2 < \dots < x_t < 5$ the surface $D \natural \bigcup_i R \times x_i$ is Thurston norm minimizing;
- (D3) the intersection $D \cap R \times [-4, 4]$ is a product surface;
- (D4) given any $i \in \{1, \dots, s\}$ the surface D intersects A_i transversely and any component of $D \cap A_i$ is either an arc or it is a closed curve which is positive;
- (D5) D is a good surface.

We first note that by Lemma 2.1 there exists a $k \in \mathbb{N}$ such that $[R]$ is subordinate to $l[R] + \psi$ for any $l \geq k$. By a general position argument we can find a Thurston norm minimizing surface C in N which represents $k[R] + \psi$, which intersects all the annuli A_i transversely and such that $C \cap R \times [-5, 5]$ is a product surface.

Since $[R]$ is subordinate to $[C]$ it follows that $[R]$ and $[C]$ lie on the closure of a Thurston cone, which in turn implies that for any $-5 < x_1 < x_2 < \dots < x_t < 5$ we have

$$x(t[R] + [C]) = x(t[R]) + x([C]) = t\chi_-(R) + \chi_-(C) = \chi_-\left(C \natural \bigcup_{i=1}^t R \times x_i\right).$$

This shows that $C \natural \bigcup_i R \times x_i$ is Thurston norm minimizing. In particular C satisfies (D1)–(D3).

We now let

$$d := \text{maximal number of negative components of any } C \cap A_i$$

and we consider

$$D := C \natural \bigcup_{i=1}^d R \times \left(4 + \frac{i}{d}\right).$$

It follows easily from $R_{i+} = (R \times 1) \cap M_i$, $i = 1, \dots, r$ that for any A_i there are now at least as many positive components of $D \cap A_i$ as there are negative components. Using the standard ‘cut and paste’ method we can arrange that given any A_i the intersection $D \cap A_i$ contains no null-homologous closed loops and no anti-parallel closed loops. Note that if we remove a pair of anti-parallel closed loops then we lower the number of positive and negative components each by one. It now follows that any component of $D \cap A_i$ is either an arc, or it is a closed curve which is positive. We thus arranged that D satisfies (D4). Since all of the above operations can be performed outside of $R \times [-4, 4]$ it is clear that D also has properties (D1)–(D3).

We finally turn D into a good surface by removing all components of D which are spheres or which bound an compressible torus. This concludes the proof of the claim.

For each A_i we now perform successively two isotopies of D in a small neighborhood of A_i , i.e. in a neighborhood which does not intersect any of the other A_j .

- (1) We first apply an isotopy outside of $R \times [-4, 4]$ which pulls the separating arcs of $D \cap A_i$ either into $A_i \cap (R \times (-5, -1])$ or into $A_i \cap (R \times [1, 5))$ and which leaves all the other intersections of D with A_i untouched.
- (2) We then apply an isotopy in $R \times [-5, -1] \cup R \times [1, 5]$ which pulls the separating arcs into $A_i \cap (R \times (-2, -1])$ or into $A_i \cap (R \times [1, 2))$ and which again leaves all the other intersections of D with A_i untouched.

Note that such isotopies exist since $D \cap A_i$ contains no null-homologous closed loops. Also note that we can perform the isotopies in such a way that the intersection of the resulting surface E with $R \times [-4, -2] \cup R \times [2, 4]$ is still a product surface. We illustrate the two isotopies in Figure 3.

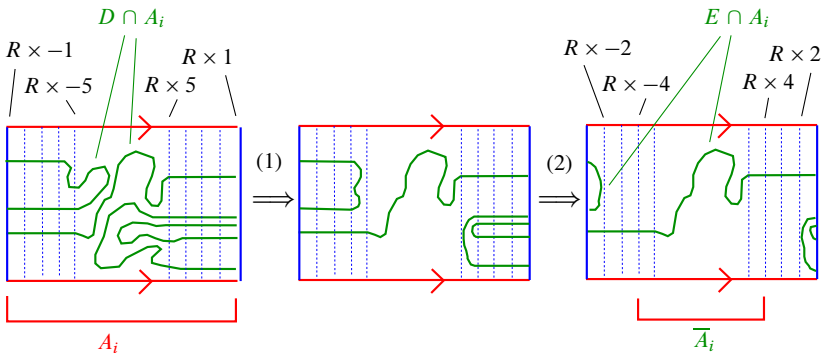

FIGURE 3
Modification of D in a neighborhood of A_i

It is now time to pause for a minute and see what we have achieved so far.

Claim. *The surface E has properties (W1)–(W4).*

We consider the sutured manifold

$$\bar{M} := N \setminus R \times (-4, 4).$$

Note that the guts and the windows of \bar{M} are precisely the intersection of the guts and the windows of $M = N \setminus R \times (-1, 1)$ with \bar{M} . In the following we write

$$\bar{M}_i = \bar{M} \cap M_i,$$

$$\bar{\gamma}_i = \bar{M} \cap \gamma_i,$$

and

$$\bar{A}_i = \bar{M} \cap A_i$$

for all i .

We first point out that properties (W1)–(W2) are preserved under isotopy, so they are clearly satisfied by E . As we discussed above, the surface E has property (W3).

Finally let \bar{A}_i be any of the annuli. It follows from (D4) and the type of isotopy we applied that any component of $E \cap \bar{A}_i = (E \cap A_i) \cap (N \setminus R \times (-4, 4))$ is either a *non-separating arc* or a closed curve which is positive. This is equivalent to saying that E satisfies (W4). This concludes the proof of the claim.

So it now remains to modify² E to arrange (W5). We will do so over the next two claims.

Claim. *There exists a good surface E which has properties (W1)–(W4) and which satisfies*

(W5') *There exists no filling ball and no filling solid tori for $(E, R \times -3 \cup R \times 3)$ which lies in $N \setminus R \times (-3, 3)$.*

We will prove the claim using the complexity $b_0(E \cap (R \times -3 \cup R \times 3))$. It suffices to show that if E is a good surface with properties (W1)–(W4) which does not satisfy (W5'), then there exists a good surface with properties (W1)–(W4) with lower complexity.

So let E be a good surface with properties (W1)–(W4) which admits a filling solid torus X for $(E, R \times -3 \cup R \times 3)$ which lies in $N \setminus R \times (-3, 3)$. Since E and R are good it follows that X touches E and $R \times -3 \cup R \times 3$. (It is in

²Note that we could of course have picked C initially such that C and $R \times -3 \cup R \times 3$ are a good pair, but this property can get lost in the step from the surface D to the surface E .

fact straightforward to see that $\partial X \cap (R \times -3 \cup R \times 3)$ lies either completely in $R \times -3$ or in $R \times 3$.) We now replace E by

$$(E \setminus (X \cap E)) \cup (X \cap (R \times -3 \cup R \times 3))$$

and push the components of $X \cap (R \times -3 \cup R \times 3)$ into $R \times (-2, 2)$. These two steps are illustrated in Figure 4.

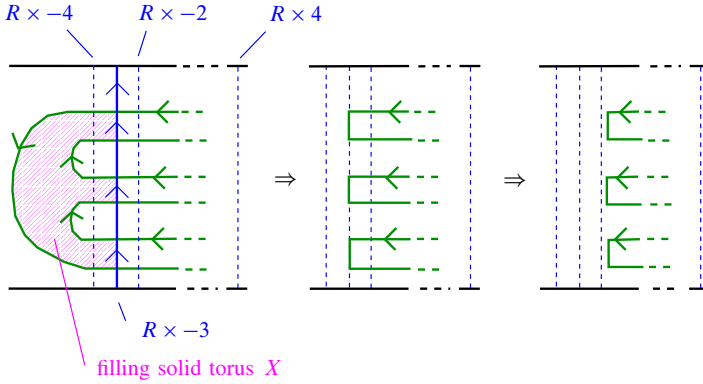

FIGURE 4

Replacing $X \cap E$ by $X \cap R \times -3$ and pushing into $R \times [-2, 2]$

Finally we delete all components of the new surface which are spheres or which bound solid tori.

Note that the fact that X is a filling solid torus implies that the resulting surface is homologous to E and in particular oriented. Also note that any component of the intersection of the new surface with any of the A_j is a component of the intersection of E with A_j . It is now straightforward to see that the resulting surface is a good surface that still has properties (W1)–(W4). Furthermore it is clear that the number of components of the intersection with $R \times -3 \cup R \times 3$ went down. We thus lowered the complexity.

We now suppose that $(E, R \times -3 \cup R \times 3)$ admits a filling ball B which lies in $N \setminus R \times (-3, 3)$. Then exactly the same argument as above, with X replaced by B , shows that we can find a new surface of lower complexity. This concludes the proof of the claim.

We now turn to the last claim of the proof of the proposition.

Claim. *There exists a good surface F which has properties (W1)–(W5).*

Let E be a good surface which has properties (W1)–(W4) and (W5'). We denote by $C_-, C_+ \subset R$ the collection of curves such that $E \cap R \times \pm 2 = C_{\pm} \times \pm 2$.

We can and will assume that C_- and C_+ are in general position. We also write $C = C_- \cup C_+$.

We denote by c the number of components of $R \setminus C$. Note that the closures of the components of $R \setminus C$ (equipped with the orientation coming from R) give naturally rise to a basis for $H_2(R, C; \mathbb{Z})$. We denote the corresponding isomorphism $H_2(R, C; \mathbb{Z}) \rightarrow \mathbb{Z}^c$ by Φ and we denote by $p: R \times [-2, 2] \rightarrow R$ the canonical projection map.

If $S \subset R \times [-2, 2]$ is a surface with $\partial S \subset C_- \times -2 \cup C_+ \times 2$, then we refer to $\Phi(p_*([S, \partial S])) \in \mathbb{Z}^c$ as the *coordinates of S* .

If $S \subset R \times [-2, 2]$ is a surface with $\partial S \subset C_- \times -2 \cup C_+ \times 2$, then we say that S is *negative* if $\Phi(p_*([S, \partial S]))$ has non-positive coordinates and at least one coordinate is negative. Similarly we define what it means for S to be positive. Note that if $S \subset R \times [-2, 2]$ is a surface with $\partial S \subset C_- \times -2$, then S is isotopic rel boundary to a surface in $R \times -2$, it follows that S is either negative or positive. The same conclusion holds for surfaces $S \subset R \times [-2, 2]$ with $\partial S \subset C_+ \times 2$.

Finally, given a surface $E \subset N$ with $E \cap (R \times -2 \cup R \times 2) = C_- \times -2 \cup C_+ \times 2$ we consider the complexity

$$- \sum_{\substack{S \text{ component} \\ \text{of } E \cap R \times [-2, 2]}} \text{sum of the negative coordinates of } \Phi(p_*([S, \partial S])).$$

In order to prove the claim it suffices to show that if E is a good surface with properties (W1)–(W4) and (W5') which does not satisfy (W5), then there exists a good surface with properties (W1)–(W4) and (W5') with lower complexity.

So let E be a good surface with properties (W1)–(W4) and (W5') with

$$E \cap (R \times -2 \cup R \times 2) = C_- \times -2 \cup C_+ \times 2$$

which admits a filling solid torus X for $(E, R \times -3 \cup R \times 3)$. Note that the intersection of X with $N \setminus R \times (-3, 3)$ is either empty, or a filling ball or a filling solid torus. By (W5') the last two cases can not occur, we thus conclude that the filling solid torus X has to lie in $R \times [-3, 3]$.

Note that the oriented surface $X \cap (R \times -3 \cup R \times 3)$ has non-negative coordinates and at least one coordinate is positive. Since $X \cap (R \times -3 \cup R \times 3)$ is homologous to $-X \cap E$ it follows that the surface $X \cap E$ has non-positive coordinates and at least one component of $X \cap E$ has a negative coordinate. Finally note that X intersects either $R \times -3$ or $R \times 3$, without loss of generality we can assume that the former is the case. By the above this implies that $X \cap E$ contains a negative component.

We pick an $x \in (-2, 2)$ such that $\partial X \cap R \times x$ is isotopic in X to $\partial X \cap R \times -2$. We now consider the surface $E \natural (R \times x)$. Note that the coordinates of $R \times x$ are $(1, \dots, 1)$. Since $R \times x$ intersects a negative component of E it is now

straightforward to verify (see e.g. Figure 5 for an illustration) that the surface $E \uplus (R \times x)$ has lower complexity than E .

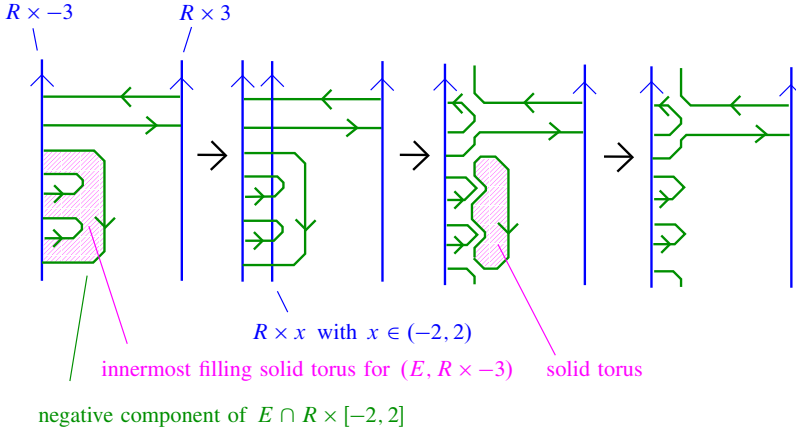

FIGURE 5

Replacing E by $E \uplus (R \times x)$ and deleting any components bounding balls and solid tori

We now delete all components of $E \uplus (R \times x)$ which bound balls or solid tori. It is easy to see, using (D2), that the resulting surface still has properties (W1)–(W4) and by the above it has lower complexity than E .

Finally, if $(E, R \times -3 \cup R \times 3)$ admits a filling ball B , then exactly the same argument as above shows that we can again find a surface which satisfies (W1)–(W4) and (W5') and which has lower complexity.

This concludes the proof of the claim. \square

We will now study how the guts are affected by decomposing along the surface which is given to us by Proposition 4.1. Before we state the next result we introduce one more definition. Let N be a closed irreducible 3-manifold. We say that a subset $G \subset N$ is *homologically visible in N* if the map

$$H_1(G; \mathbb{Z}) \longrightarrow H_1(N; \mathbb{Z})/\text{torsion}$$

is non-trivial. Otherwise we say that G is *invisible*.

We can now formulate the following proposition.

Proposition 4.2. *Let N be a closed irreducible connected 3-manifold and let $R \subset N$ be a good Thurston norm minimizing surface. We pick an admissible decomposition surface for $N \setminus R \times (-4, 4)$. Suppose that $m \in \mathbb{N}$ and $F \subset N$ have properties (W1)–(W5). We put*

$$S = (R \times -3 \cup R \times 3) \uplus F.$$

Then there exists an admissible decomposition surface for $N(S)$ such that to each gut G of $N \setminus R \times (-4, 4)$ we can associate a collection $\Phi(G)$ of guts of $N(S)$ with the following properties.

- (1) The guts of $N(S)$ are the disjoint union of all the $\Phi(G)$.
- (2) Any gut in $\Phi(G)$ is a subset of G .
- (3) If G is invisible, then any gut in $\Phi(G)$ is also invisible.
- (4) If G is a gut of $N(R)$, then one of the following two statement holds:
 - (a) either any element in $\Phi(G)$ has lower complexity than G ,
 or
 - (b) $\Phi(G)$ consists of one element G' and there exists an isotopy of N which restricts to a diffeomorphism $G \rightarrow G'$ as sutured manifolds.
- (5) If G is a gut such that $[F \cap G] \neq 0 \in H_2(G, \partial G; \mathbb{Z})$, then any element in $\Phi(G)$ has lower complexity than G .

Proof. We consider the sutured manifold $M = N \setminus R \times (-4, 4)$. We pick an admissible decomposition surface A for M . Recall that we assumed that N is closed, which implies that the sutured manifold M has no sutures, which in turn implies that A consists only of admissible annuli. We denote by G_1, \dots, G_k the corresponding guts and by P_1, \dots, P_l the corresponding windows of M . By (W4) we can decompose G_1, \dots, G_k and P_1, \dots, P_l along F and we obtain new sutured manifolds G_1^F, \dots, G_k^F and P_1^F, \dots, P_l^F .

We also consider the product sutured manifold

$$Q := R \times [-2, 2].$$

We can decompose Q along $F \cap Q$ and we obtain a sutured manifold Q^F . Note that we can and will identify $N(R \times -3 \cup R \times 3)$ with $Q \cup M$.

Finally we put

$$S = (R \times -3 \cup R \times 3) \natural F$$

and we consider the following diagram

$$\begin{array}{ccccc}
 N & \xrightarrow{R \times -3 \cup R \times 3} & Q \cup M & \xrightarrow{A} & Q \cup \bigcup_i G_i \cup \bigcup_i P_i \\
 \downarrow S & & \downarrow F & & \downarrow F \\
 N(S) & \xrightarrow{C} & X & \xrightarrow{A \cap X} & Q^F \cup \bigcup_i G_i^F \cup \bigcup_i P_i^F.
 \end{array}$$

We now make several explanations and observations.

- (1) The decompositions along F are understood to be along the intersection of F with the given submanifold of N .
- (2) It follows from (W2) and (W5) and from Lemma 3.4 that $N(S)$ is taut.
- (3) By C we denote the union of the decomposition annuli from Lemma 3.4 which correspond to the components of $F \cap (R \times -3 \cup R \times 3)$.
- (4) It follows from Lemma 3.4 that the first square of the diagram is commutative. It is straightforward to verify that the second square is also commutative.
- (5) It follows from (W4) that the components of C and $A \cap X$ are admissible annuli and admissible disks.

We now let $B = C \cup (A \cap X)$. It follows from the above that B is an admissible decomposition surface for $N(S)$. It is well-known that if we decompose a product sutured manifold along a taut decomposition surface, then the result is also a product sutured manifold. (This can be seen for example by the classification of Thurston norm minimizing surfaces in $S^1 \times \Sigma$.) We thus see that the guts of $N(S)$ with respect to B are precisely the disjoint union of the non-product components of the G_i^F .

To each gut G_i of $N(R)$ we now associate

$$\Phi(G_i) := \text{non-product components of } G_i^F.$$

By the above the guts of $N(S)$ are the disjoint union of $\{\Phi(G_i)\}_{i=1,\dots,k}$. By construction any $J \in \Phi(G_i)$ is a subset of G_i . In particular the map $H_1(J; \mathbb{Z}) \rightarrow H_1(N; \mathbb{Z})$ factors through $H_1(G_i; \mathbb{Z}) \rightarrow H_1(N; \mathbb{Z})$. It follows that if G_i is invisible, then any component of G_i^F is invisible as well. It furthermore follows immediately from Theorem 3.5, applied iteratively to the components of $F \cap G_i$, that the fourth and the fifth statement also hold. \square

5. The proof of the Virtual Fibering Theorem

For the reader's convenience we recall Agol's theorem.

Theorem 5.1 (Agol). *Let N be an irreducible connected 3-manifold with empty or toroidal boundary such that $\pi_1(N)$ is virtually RFRS. Let $\phi \in H^1(N; \mathbb{Q})$ be non-trivial. Then there exists a finite cover $q: \tilde{N} \rightarrow N$ such that $q^*\phi$ is subordinate to a fibered class.*

In Section 5.1 we will provide the proof of Theorem 5.1 in the case of closed 3-manifolds. In Section 5.2 we will then deduce the case of non-trivial boundary from the closed case by a ‘doubling’ argument.

5.1. The Virtual Fibring Theorem for closed 3-manifolds. In this section we will give a proof of Theorem 5.1 in the case that N is a closed irreducible connected 3-manifold with virtually RFRS fundamental group. Let $\phi \in H^1(N; \mathbb{Q})$ be non-trivial. In light of Lemma 2.1 (4) we can without loss of generality assume that $\pi = \pi_1(N)$ is already RFRS. We can therefore find a filtration $\pi = \pi_0 \supset \pi_1 \supset \pi_2 \dots$ such that the following hold:

- (1) $\bigcap_k \pi_k = \{1\}$;
- (2) for any k the group π_k is a normal, finite index subgroup of π ;
- (3) for any k the map $\pi_k \rightarrow \pi_k/\pi_{k+1}$ factors through $\pi_k \rightarrow H_1(\pi_k; \mathbb{Z})/\text{torsion}$.

Given a non-trivial subgroup $\Gamma \subset \pi_k$ we define its *invisibility* $i(\Gamma \subset \pi_k)$ as follows:

$$i(\Gamma \subset \pi_k) := \min\{l \in \mathbb{N} \mid \Gamma \subset \pi_{k+l} \text{ and } H_1(\Gamma; \mathbb{Z}) \rightarrow H_1(\pi_{k+l}; \mathbb{Z})/\text{torsion} \text{ is non-trivial}\}.$$

It follows from properties (1) and (3) of a RFRS group that the invisibility of any non-trivial subgroup is defined.

In the following, given $k \in \mathbb{N}$, we denote by N_k the cover of N corresponding to π_k and for $j \geq k$ we denote the covers $N_j \rightarrow N_k$ by q . Now let $R \subset N_k$ be a good Thurston norm minimizing surface. We pick an admissible decomposition surface for $N_k(R)$. We say that two guts G and G' of $N_k(R)$ are *equivalent* if there exists a deck transformation Φ of the covering $N_k \rightarrow N$ and an isotopy Ψ of N_k such that $\Psi \circ \Phi$ restricts to a diffeomorphism $G \rightarrow G'$ of sutured manifolds. Note that equivalent guts have in particular the same complexity.

We can now introduce the following invariants:

$$m_c(N_k, R) := \text{maximal complexity of a gut of } N_k(R),$$

$$n_c(N_k, R) := \text{number of equivalence classes of guts of } N_k(R) \\ \text{with maximal complexity,}$$

$$i(N_k, R) := \text{maximal invisibility among all guts of } N_k(R) \\ \text{with maximal complexity,}$$

$$m_v(N_k, R) := \text{maximal complexity of a visible gut of } N_k(R),$$

$$n_v(N_k, R) := \text{number of equivalence classes of visible guts of } N_k(R) \\ \text{with maximal complexity.}$$

If $N_k(R)$ has no guts, then all these invariants are understood to be 0.

We now consider the lexicographically ordered quintuple

$$(m_c(N_k, R), n_c(N_k, R), i(N_k, R), m_v(N_k, R), n_v(N_k, R)),$$

and we define $f(N_k, R)$ to be the minimum of all these quintuples, where we take the minimum over all admissible decomposition surfaces for $N_k(R)$. Note that $f(N_k, R)$ is the zero vector if and only if $N_k(R)$ is a product, i.e. if R is a fiber of a fibration.

We now want to prove the following lemma, which by the above implies the theorem.

Lemma 5.2. *Let R be a good Thurston norm minimizing surface in N . Then there exists a j and a good Thurston norm minimizing surface R_j in N_j such that the following two conditions hold:*

(1) $q^*([R]) \in H_2(N_j; \mathbb{Z})$ is subordinate to $[R_j]$,

and

(2) $f(N_j, R_j)$ is the zero vector.

This lemma in turn follows from the following lemma.

Lemma 5.3. *Let R_k be a good Thurston norm minimizing surface in N_k such that $f(N_k, R_k)$ is not the zero vector. Then there exists a $j \geq k$ and a good Thurston norm minimizing surface \tilde{R}_j in N_j such that*

(1) $q^*([R_k]) \in H_2(N_j; \mathbb{Z})$ is subordinate to $[\tilde{R}_j]$,

and

(2) $f(N_j, \tilde{R}_j) < f(N_k, R_k)$.

Pick an admissible decomposition surface for $N_k(R_k)$ which realizes $f(N_k, R_k)$. In our proof of Lemma 5.3 we first suppose that every gut of $N_k(R_k)$ is invisible. We then consider the covering $q: N_{k+1} \rightarrow N_k$ and we write $R_{k+1} = q^{-1}(R_k)$. It follows from Proposition 3.3 that the guts of $N_{k+1}(R_{k+1})$ are precisely the preimages under q of the guts of $N_k(R_k)$. Now note that if G is a gut of $N_k(R_k)$, then the assumption that G is invisible implies that the map

$$\pi_1(G) \longrightarrow \pi_1(N_k) \longrightarrow H_1(N_k; \mathbb{Z})/\text{torsion} \longrightarrow \pi_k/\pi_{k+1}$$

is trivial. This implies that the components of $q^{-1}(G)$ are all diffeomorphic to G . It follows that $m_c(N_{k+1}, R_{k+1}) = m_c(N_k, R_k)$.

Note that all the components of $q^{-1}(G)$ are furthermore equivalent. Since the map $N_{k+1} \rightarrow N$ is a regular cover it now follows easily that two guts of $N_{k+1}(R_{k+1})$ are equivalent if and only if their projections to $N_k(R_k)$ are equivalent. We thus see that $n_c(N_{k+1}, R_{k+1}) = n_c(N_k, R_k)$. On the other hand we have $i(N_{k+1}, R_{k+1}) = i(N_k, R_k) - 1$. We thus showed that $f(N_{k+1}, R_{k+1}) < f(N_k, R_k)$.

We now turn to the case that there exists a gut of $N_k(R_k)$ which is visible. Among all visible guts of $N_k(R_k)$ we take a gut G of maximal complexity. We

denote by $G_1 = G, G_2, \dots, G_l$ the guts which are equivalent to G . Note that all these guts are also visible. There exists therefore a homomorphism $H_1(N; \mathbb{Z}) \rightarrow \mathbb{Z}$ which is non-trivial when restricted to each G_j . Put differently, there exists a $\psi \in H_2(N_k; \mathbb{Z}) = H^1(N_k; \mathbb{Z})$ such that the restriction to each G_j is non-zero.

By Proposition 4.1 there exists an $m \in \mathbb{N}$ such that $[R_k]$ is subordinate to $m[R_k] + \psi$ and a surface F in N_k which represents $m[R_k] + \psi$ and which has properties (W2)–(W5). We set $S = (R \times -3 \cup R \times 3) \uplus F$. It now suffices to show the following claim.

Claim. $f(N_k, S) < f(N_k, R_k)$.

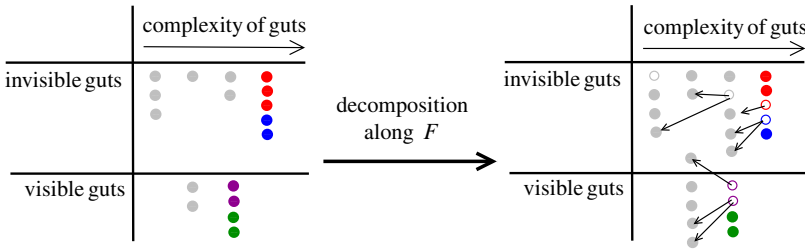

FIGURE 6

Schematic picture of the decomposition of guts along F : guts get cut into pieces of smaller complexity and invisible guts stay invisible. The colors indicate equivalence classes of guts.

We equip $N_k(S)$ with the admissible decomposition surface coming from Proposition 4.2. We then note that it follows immediately from Proposition 4.2 (1) and (4) that (up to isotopy)

$$\begin{aligned} & \{\text{guts of } N_k(S) \text{ of complexity } m_c(N_k, R_k)\} \\ & \subset \{\text{guts of } N_k(R_k) \text{ of complexity } m_c(N_k, R_k)\}, \end{aligned}$$

and that furthermore no gut of $N_k(S)$ has complexity larger than $m_c(N_k, R_k)$. It follows that

$$(1) \quad (m_c(N_k, S), n_c(N_k, S), i(N_k, S)) \leq (m_c(N_k, R_k), n_c(N_k, R_k), i(N_k, R_k)).$$

Furthermore it follows from Proposition 4.2 (1), (3) and (4) that $N_k(S)$ contains no visible gut of complexity larger than $m_v(N_k, R_k)$ and that

$$\begin{aligned} & \{\text{visible guts of } N_k(S) \text{ of complexity } m_v(N_k, R_k)\} \\ & \subset \{\text{visible guts of } N_k(R_k) \text{ of complexity } m_v(N_k, R_k)\}. \end{aligned}$$

Now note that for any G_j we have

$$[S]|_{G_j} = (m[R_k] + \psi)|_{G_j} = \psi|_{G_j} \neq 0 \in H_2(G_j, \partial G_j; \mathbb{Z}).$$

It therefore follows from Proposition 4.2 (4) and (5) that

$$\begin{aligned} & \#\{\text{equivalence classes of visible guts of } N_k(S) \text{ of complexity } m_v(N_k, R_k)\} \\ & \leq \#\{\text{equivalence classes of visible guts of } N_k(R_k) \\ & \quad \text{of complexity } m_v(N_k, R_k)\} - 1. \end{aligned}$$

Putting these observations together we see that

$$(2) \quad (m_v(N_k, S), n_v(N_k, S)) < (m_v(N_k, R_k), n_v(N_k, R_k)).$$

Combining the inequalities (1) and (2) we see that $f(N_k, S) < f(N_k, R_k)$. This concludes the proof of the claim and thus of Theorem 5.1.

For the purpose of the next section we also state the following lemma which we implicitly proved in the above:

Lemma 5.4. *Let N be a closed irreducible 3-manifold and let $R \subset N$ be a good Thurston norm minimizing surface. We pick an admissible decomposition surface for $N(R)$. Suppose there exists a filtration $\pi = \pi_0 \supset \pi_1 \supset \pi_2 \dots$ such that the following hold:*

- (1) *for any gut G of $N(R)$ we have $\cap_k(\pi_1(G) \cap \pi_k) = \{1\}$;*
- (2) *for any k the group π_k is a normal, finite index subgroup of π ;*
- (3) *for any k the map $\pi_k \rightarrow \pi_k/\pi_{k+1}$ factors through $\pi_k \rightarrow H_1(\pi_k; \mathbb{Z})/\text{torsion}$.*

Then there exists a finite cover $q: \tilde{N} \rightarrow N$ such that $q^([R])$ is subordinate to a fibered class.*

5.2. The Virtual Fibering Theorem for 3-manifolds with non-trivial boundary.

We will now give a proof of Theorem 5.1 in the case that N has non-trivial toroidal boundary. One approach would be to adapt the proof of the previous section. In fact quickly browsing through the proof shows that the only aspect which needs to be modified is the statement and the proof of Proposition 4.1. This can be done, but the proof of Proposition 4.1 becomes even less readable.

We therefore employ a slightly roundabout way which is inspired by the proof of [Ag08], Theorem 6.1. In the following let N be an irreducible connected 3-manifold with non-trivial toroidal boundary such that $\pi_1(N)$ is virtually RFRS. The theorem trivially holds for $N = S^1 \times D^2$, we therefore henceforth assume that $N \neq S^1 \times D^2$. Let $\phi \in H^1(N; \mathbb{Q})$ be non-trivial. In light of Lemma 2.1 (4) we can again assume that $\pi = \pi_1(N)$ is already RFRS. We pick a RFRS filtration $\{\pi_k\}_{k \in \mathbb{N}} \in \mathbb{N}$ for π .

We denote by W the double of N along its boundary, i.e. $W = N \cup_{\partial N = \partial N'} N'$ where N' is a copy of N . We consider the inclusion map $i: N \rightarrow W$ and the retraction $r: W \rightarrow N$. We also consider $R := \partial N = \partial N' \subset W$ and $\Phi := r^*\phi \in H^1(W; \mathbb{Z}) = H_2(W; \mathbb{Z})$. Note that R is a good surface since N is irreducible and $N \neq S^1 \times D^2$. It follows from Proposition 4.1 and the proof of Proposition 4.2 that there exists a surface S of the form $S = F \uplus (R \times -1 \cup R \times 1)$ such that $[S] = k[R] + \Phi$ for some $k \in \mathbb{N}$ and such that, for a suitable choice of admissible decomposition surface, the guts of S are contained in $W \setminus R \times (-1, 1)$.

Note that the Thurston norm of $[R]$ is zero, it follows that Φ and $[S]$ lie in the same Thurston cone, in particular Φ is subordinate to $[S]$. We now apply Lemma 5.4 to the filtration given by $\text{Ker}(\pi_1(W) \rightarrow \pi_1(N) \rightarrow \pi/\pi_k)$, $k \in \mathbb{N}$ and the surface S . Since each gut of S is contained in one of the two copies of N , and since $\{\pi_k\}_{k \in \mathbb{N}} \in \mathbb{N}$ is a RFRS filtration it follows that the conditions of Lemma 5.4 are satisfied. There exists therefore a finite cover $q: \tilde{W} \rightarrow W$ such that $q^*([S])$ is subordinate to a fibered class $\tilde{\Psi}$. It follows from Lemma 2.1 that $\tilde{\Phi} := q^*\Phi$ is also subordinate to the fibered class $\tilde{\Psi}$.

We now denote by $\tilde{N} \subset \tilde{W}$ a connected component of $q^{-1}(N)$. We recycle the above notation by denoting the covering map $\tilde{N} \rightarrow N$ by q and the inclusion map $\tilde{N} \rightarrow \tilde{W}$ by i . Since $N \neq S^1 \times D^2$ we can view \tilde{N} as a union of JSJ components of \tilde{W} . It follows from [EN85], Theorem 4.2, that $\tilde{\psi} := i^*\tilde{\Psi} \in H^1(\tilde{N}; \mathbb{Q})$ is also fibered.

It remains to show that $\tilde{\phi} := q^*\phi$ is subordinate to $\tilde{\psi}$. We first note that the fact that $\tilde{\Phi} := q^*\Phi$ is subordinate to $\tilde{\Psi}$ implies that

$$(3) \quad x_{\tilde{W}}(\tilde{\Phi}) + x_{\tilde{W}}(\tilde{\Psi}) = x_{\tilde{W}}(\tilde{\Phi} + \tilde{\Psi}).$$

We denote by \tilde{M} the closure of $\tilde{W} \setminus \tilde{N}$. Note that \tilde{N} and \tilde{M} are a union of JSJ components of \tilde{W} . It now follows immediately from [EN85], Proposition 3.5, that for any class $\tilde{\Theta} \in H^1(\tilde{N}; \mathbb{Q})$ we have

$$x_{\tilde{W}}(\tilde{\Theta}) = x_{\tilde{N}}(\tilde{\Theta}|_{\tilde{N}}) + x_{\tilde{M}}(\tilde{\Theta}|_{\tilde{M}}).$$

Since $x_{\tilde{M}}$ is a seminorm it follows immediately from (3) that

$$x_{\tilde{N}}(\tilde{\phi}) + x_{\tilde{N}}(\tilde{\psi}) = x_{\tilde{N}}(\tilde{\phi} + \tilde{\psi}).$$

This shows that $\tilde{\phi}$ and $\tilde{\psi}$ lie on the closure of a Thurston cone. We now recall that the fact that $\tilde{\psi}$ is fibered implies that $\tilde{\psi}$ lies in a top dimensional Thurston cone. Combining these two statements implies that $\tilde{\phi}$ is in fact subordinate to the fibered class $\tilde{\psi}$.

This concludes the proof of Theorem 5.1 in the case that N has non-trivial boundary.

References

- [Ag08] I. AGOL, Criteria for virtual fibering. *J. Topol.* **1** (2008), 269–284. [MR 2399130](#)
[Zbl 1148.57023](#)
- [Ag13] —, The virtual Haken conjecture. With an appendix by I. Agol, D. Groves, and J. Manning. *Doc. Math.* **18** (2013), 1045–1087. [MR 3104553](#)
[Zbl 06220364](#)
- [ABZ08] I. AGOL, S. BOYER and X. ZHANG, Virtually fibered Montesinos links. *J. Topol.* **1** (2008), 993–1018. [MR 2461863](#) [Zbl 1168.57004](#)
- [AR99] I. AITCHISON and J. RUBINSTEIN, Polyhedral metrics and 3-manifolds which are virtual bundles. *Bull. London Math. Soc.* **31** (1999), 90–96. [MR 1651060](#) [Zbl 0930.57015](#)
- [AFW12] M. ASCHENBRENNER, S. FRIEDL and H. WILTON, 3-manifold groups. Preprint 2012. [arXiv:1205.0202](#) [math.GT]
- [Br99] M. BRIDSON, Non-positive curvature in group theory. In C.M. CAMPBELL, E.F. ROBERTSON, N. RUSKUC and G.C. SMITH, *Groups St. Andrews 1997 in Bath*. Volume I. London Mathematical Society Lecture Note Series 260. Cambridge University Press, Cambridge, 1999. 124–175 [MR 1676614](#) [Zbl 0922.20044](#)
- [Br01] —, On the subgroups of semihyperbolic groups. In É. GHYS, P. DE LA HARPE, V.F.R. JONES, V. SERGIESCU and T. TSUBOI (eds.), *Essays on Geometry and Related Topics*. Volume 1. Monographies de l’Enseignement Mathématique 38. L’Enseignement Mathématique, Genève, 85–111. [MR 1929323](#) [Zbl 1053.20038](#)
- [Bu05] J.O. BUTTON, Fibred and virtually fibred hyperbolic 3-manifolds in the censuses. *Exp. Math.* **14** (2005), 231–255. [MR 2169525](#) [Zbl 1085.57012](#)
- [CC03] A. CANDEL and L. CONLON, *Foliations*. Volume II. Graduate Studies in Mathematics 60. American Mathematical Society, Providence, RI, 2003. [MR 1994394](#) [Zbl 1035.57001](#)
- [DeB10] J. DEBLOIS, On the doubled tetrus. *Geom. Dedicata* **144** (2010), 1–23. [MR 2580415](#) [Zbl 1197.57016](#)
- [EN85] D. EISENBUD and W. NEUMANN, *Three-Dimensional Link Theory and Invariants of Plane Curve Singularities*. Annals of Mathematics Studies 110. Princeton University Press, Princeton, NJ, 1985. [MR 0817982](#)
[Zbl 0628.57002](#)
- [FV12] S. FRIEDL and S. VIDUSSI, The Thurston norm and twisted Alexander polynomials. *J. Reine Angew. Math.* To appear. Preprint 2012. [arXiv:1204.6456](#) [math.GT]
- [FV14] S. FRIEDL and S. VIDUSSI, Minimal genus on 4-manifolds with a free circle action. *Adv. Math.* **250** (2014), 570–587. [Zbl 06284417](#)
- [Ga83] D. GABAI, Foliations and the topology of 3-manifolds. *J. Differ. Geometry* **18** (1983), 445–503. [MR 0723813](#) [Zbl 0533.57013](#)
- [Ga86] —, On 3-manifolds finitely covered by surface bundles. In D.B.A. EPSTEIN, *Low-dimensional topology and Kleinian groups*. London Mathematical Society Lecture Note Series 112. Cambridge University Press, Cambridge, 1986, 145–155. [MR 0903863](#) [Zbl 0624.57011](#)

- [GZ09] X. GUO and Y. ZHANG, Virtually fibred Montesinos links of type $\widetilde{SL(2)}$. *Topology Appl.* **156** (2009), 1510–1533. [MR 2512604](#) [Zbl 1175.57006](#)
- [Ju06] A. JUHÁSZ, Holomorphic discs and sutured manifolds. *Algebr. Geom. Topol.* **6** (2006), 1429–1457. [MR 2253454](#) [Zbl 1129.57039](#)
- [Ju08] —, Floer homology and surface decompositions. *Geom. Topol.* **12** (2008), 299–350. [MR 2390347](#) [Zbl 1167.57005](#)
- [He76] J. HEMPEL, *3-manifolds*. Annals of Mathematics Studies 86. Princeton University Press, Princeton, N. J., and University of Tokyo Press, Tokyo, 1976. Reprint, AMS Chelsea Publishing, Providence, RI, 2004. [MR 0415619](#) [MR 2098385](#) (reprint) [Zbl 0345.57001](#)
- [Leb95] B. LEEB, 3-manifolds with(out) metrics of nonpositive curvature. *Invent. Math.* **122** (1995), 277–289. [MR 1358977](#) [Zbl 0840.53031](#)
- [Lei02] C. LEININGER, Surgeries on one component of the Whitehead link are virtually fibered. *Topology* **41** (2002), 307–320. [MR 1876892](#) [Zbl 0991.57018](#)
- [Li11] Y. LIU, Virtual cubulation of nonpositively curved graph manifolds. *J. Topol.* **6** (2013), 793–822. [MR 3145140](#) [Zbl 06272687](#)
- [MSY82] W.H. MEEKS, L. SIMON and S. YAU, Embedded minimal surfaces, exotic spheres, and manifolds with positive Ricci curvature. *Ann. of Math. (2)* **116** (1982), 621–659. [MR 0678484](#) [Zbl 0521.53007](#)
- [MS88] J. MORGAN and P. SHALEN, Degenerations of hyperbolic structures. II. Measured laminations in 3-manifolds. *Ann. of Math. (2)* **127** (1988), 403–456. [MR 0932305](#) [Zbl 0656.57003](#)
- [Oe86] U. OERTEL, Homology branched surfaces: Thurston’s norm on $H_2(M^3)$. In D. B. A. Epstein, *Low-dimensional topology and Kleinian groups*. London Mathematical Society Lecture Note Series 112. Cambridge University Press, Cambridge, 1986, 253–272. [MR 0903869](#) [Zbl 0628.57011](#)
- [PW11] P. PRZYTYCKI and D. T. WISE, Graph manifolds with boundary are virtually special. *J. Topol.* To appear. Preprint 2012. [arXiv:1110.3513](#) [math.GT]
- [PW12] P. PRZYTYCKI and D. T. WISE, Mixed 3-manifolds are virtually special. Preprint (2012). [arXiv:1205.6742](#) [math.GR]
- [Re95] A. REID, A non-Haken hyperbolic 3-manifold covered by a surface bundle. *Pacific J. Math.* **167** (1995), 163–182. [MR 1318168](#) [Zbl 0817.57014](#)
- [Sc89] M. SCHARLEMANN, Sutured manifolds and generalized Thurston norms. *J. Differential Geom.* **29** (1989), no. 3, 557–614. [MR 0992331](#) [Zbl 0673.57015](#)
- [Th82] W.P. THURSTON, Three dimensional manifolds, Kleinian groups and hyperbolic geometry. *Bull. Amer. Math. Soc. (N.S.)* **6** (1982), 357–379. [MR 0648524](#) [Zbl 0496.57005](#)
- [Th86] —, A norm for the homology of 3-manifolds. *Mem. Amer. Math. Soc.* **59** (1986), i–vi and 99–130. [MR 0823443](#) [Zbl 0585.57006](#)
- [TW96] J. TOLLEFSON and N. WANG, Taut normal surfaces. *Topology* **35** (1996), 55–75. [MR 1367275](#) [Zbl 0868.57022](#)
- [Wa05] G. WALSH, Great circle links and virtually fibered knots. *Topology* **44** (2005), 947–958. [MR 2153978](#) [Zbl 1087.57005](#)

- [Wi12] D. T. WISE, The structure of groups with a quasi-convex hierarchy. Preprint 2012. Revised notes of the seminar held at the conference *3-Manifolds, Artin Groups and Cubical Geometry*, CUNY Graduate Center, New York, N.Y., August 1–5, 2011.
<http://www.math.u-psud.fr/~haglund/Hierarchy29Feb2012.pdf>

(Reçu le 21 janvier 2013)

Stefan FRIEDL, Fakultät für Mathematik, Universität Regensburg, D-93040 Regensburg, Germany

e-mail: sfriedl@gmail.com

Takahiro KITAYAMA, Department of Mathematics, Tokyo Institute of Technology, 2-12-1 Ookayama, Meguro-ku, Tokyo 152-8551, Japan

e-mail: kitayama@math.titech.ac.jp