

Report No. 11/2022

DOI: 10.4171/OWR/2022/11

Geometric Structures in Group Theory

Organized by
Martin Bridson, Oxford
Cornelia Drutu, Oxford
Linus Kramer, Münster
Bertrand Rémy, Palaiseau

27 February – 5 March 2022

ABSTRACT. The conference was in the area of geometric group theory, the field of mathematics in which one studies infinite groups (finitely generated, or more generally locally compact, countable etc.) via actions on spaces endowed with various structures (geometric, measurable, analytic etc.). The surging current activity in the field is drawing more and more connections with other mathematical areas, and this was successfully reflected in the program of this week, during which problems in algebraic topology, representation theory and functional analysis, to name just a few, featured prominently alongside core topics in the area.

Mathematics Subject Classification (2020): 20Fxx, 57Mxx.

Introduction by the Organizers

During this meeting, a good balance was found between reporting on the most recent advances on classical questions of geometric group theory, and on work at the boundary with other fields, either on relevant problems coming from those fields or on tools and ideas newly imported from geometry and analysis to resolve core problems in group theory.

In the first setting, many questions are motivated by the fact that hyperbolic groups can be seen as generalizations of free groups, and a focus on this idea prompts many natural questions of an algebraic nature. A fundamental result from this perspective is that a hyperbolic group admits many quotients, often hyperbolic themselves. This raises the problem of understanding the full range of possible quotients (equivalently, the range of normal subgroups), investigating the residual properties of the group. Another source of questions, more related to the

geometry of (the Cayley graphs of) finitely generated groups, is the study of the growth of elements counted according to their length, of isoperimetric problems and of boundaries of groups.

While such basic questions are for the most part solved in the Gromov hyperbolic setting, they are open and considerably more difficult when dealing with weaker forms of hyperbolicity and non-positive curvature. The study of such conditions is motivated both by analogies with classical cases, such as non-uniform lattices of hyperbolic spaces, and by the fact that they are satisfied by a wealth of new classes of discrete groups, that are not Gromov hyperbolic but have some hyperbolic features. It turns out that it is often best to define weakened notions of hyperbolicity in terms of actions on suitable spaces rather than via the intrinsic large scale geometry of the group itself.

The same analogy with classical cases (e.g. finitely generated groups of matrices and, more specifically, arithmetic subgroups of Lie groups) leads to beautiful and deep problems such as establishing the validity of Kazhdan's famous property (T), the study of amenability, for both groups and specific actions, and variants of the Tits alternative (asserting that a group is either virtually solvable or contains a non-abelian free subgroup). All these questions make sense for important classes of groups such as mapping class groups $MCG(\Sigma)$ of surfaces, groups of outer automorphisms $Out(F_n)$ of non-abelian free groups and isometry groups of (possibly exotic) buildings. The common feature of these situations is that one can no longer rely on the linearity of the groups and more geometric arguments and tools must be used instead.

An important current trend in the field is the tendency to consider questions or use tools of a more analytic nature. For instance, there is great interest in strengthening property (T) by investigating the existence of fixed point properties for affine actions on more general Banach spaces, rather than just Hilbert spaces – this is an important topic in the field of rigidity theory of group actions. The use of operator algebras to define new invariants for groups is likewise an important approach to many questions, from the viewpoint of group (co)homology and algebraic or differential topology. Similarly, ideas from probability theory at various levels, for instance Markov chains on groups or invariant random subgroups (i.e. probability measures on the compact space of closed subgroups of a group) play an increasingly prominent role in geometric group theory. All of this was well illustrated in the list of the 25 talks given during the week.

We had 50 participants (37 in person and 13 remote) from a wide range of countries, and 25 official lectures.

The staff in Oberwolfach was—as always—extremely supportive, courteous and helpful.

We are very grateful for the additional funding for 3 young PhD students and recent postdocs through Oberwolfach-Leibniz-Fellowships. We think that this provided a great opportunity for these students to be immersed in main trends of the area at an early stage in their career.

We believe that the meeting was a great success; many colleagues were delighted to have an in-person meeting, the first in many months for some of them. Each lecture was an opportunity for the speaker to present a high level result. The liveliness of the question sessions and of the more informal conversations during breaks and in the evening showed clearly that talks were dealing with up-to-date questions and suggesting important directions for further research.

Workshop: Geometric Structures in Group Theory

Table of Contents

Pierre-Emmanuel Caprace (joint with Martin Kassabov)	
<i>Hyperbolic Kazhdan groups with large finite simple quotients</i>	523
Ursula Hamenstädt	
<i>A boundary for mapping class groups</i>	524
Camille Horbez (joint with Vincent Guirardel)	
<i>Measure equivalence rigidity of $\text{Out}(F_N)$</i>	525
Emmanuel Breuillard (joint with Oren Becker, Péter Varjú)	
<i>Random character varieties</i>	528
Elia Fioravanti	
<i>Automorphisms and splittings of special groups</i>	530
Bakul Sathaye (joint with Kasia Jankiewicz, Annette Karrer, and Kim Ruane)	
<i>Boundary rigidity of groups acting on products of trees</i>	532
Koji Fujiwara (joint with Zlil Sela)	
<i>Rates of growth of acylindrically hyperbolic groups</i>	534
Denis Osin	
<i>Isoperimetric inequalities in finitely generated groups</i>	535
Alessandro Sisto (joint with Antoine Goldsborough)	
<i>Markov chains on groups and quasi-isometries</i>	535
Nathalie Wahl (joint with Oscar Harr and Max Vistrup)	
<i>A new proof of best slope homological stability for mapping class groups of surfaces</i>	537
Claudio Llosa Isenrich (joint with Bruno Martelli, Pierre Py)	
<i>Subgroups of hyperbolic groups of type F_3 and not F_4</i>	539
Robert Kropholler (joint with Noel Brady and Ignat Soroko)	
<i>Homological filling functions and the word problem</i>	542
Uri Bader (joint with Boutonnet-Houdayer-Peterson and Vigdorovich)	
<i>Charmenability</i>	544
Roman Sauer (joint with Sabine Braun)	
<i>Balls in essential manifolds and actions on Cantor spaces</i>	545
Piotr W. Nowak (joint with M. Kaluba and D. Kielak)	
<i>Property (T) for $\text{Aut}(F_n)$</i>	546

Petra Schwer (joint with Elizabeth Milićević, Yusra Naqvi and Anne Thomas)	
<i>Shadows of galleries in buildings</i>	547
Damien Gaboriau (joint with Miklos Abert, Nicolas Bergeron and Mikolaj Fraczyk)	
<i>On the homology torsion growth for $SL_d(\mathbf{Z})$, Artin groups and mapping class groups</i>	551
Shahar Mozes (joint with Irit Dinur, Shai Evra, Ron Livne, Alexander Lubotzky)	
<i>Locally testable codes</i>	552
Karen Vogtmann (joint with Michael Borinsky)	
<i>Euler characteristics of complexes of graphs</i>	554
Tim de Laat (joint with Goulnara Arzhantseva, Dawid Kielak, Damian Sawicki)	
<i>Origami expanders</i>	555
Giles Gardam	
<i>The Kaplansky conjectures</i>	558
Federico Vigolo (joint with Arielle Leitner)	
<i>An invitation to coarse groups</i>	560
Peter Kropholler	
<i>Condensed Mathematics</i>	563
Damian Osajda (joint with Piotr Przytycki)	
<i>Groups acting almost freely on 2-dimensional $CAT(0)$ complexes satisfy the Tits Alternative</i>	566
Mikael de la Salle (joint with Amine Marrakchi)	
<i>Group actions on L_p-spaces : dependance on p</i>	567
Vincent Guirardel (joint with Camille Horbez)	
<i>A strong Tits alternative for $Out(F_N)$.</i>	569

Abstracts

Hyperbolic Kazhdan groups with large finite simple quotients

PIERRE-EMMANUEL CAPRACE

(joint work with Martin Kassabov)

Recall that a discrete group G is said to satisfy **Kazhdan’s property (T)** if there is a non-empty finite subset $Q \subset G$ and a constant $\varepsilon > 0$ such that the following condition is satisfied by every unitary representation π of G : if there is a vector v such that $\|\pi(q)v - v\| < \varepsilon\|v\|$ for all $q \in Q$, then G fixes a non-zero vector w . Historically, the first known examples of discrete groups with property (T), highlighted by Kazhdan himself, were lattices in simple Lie groups of rank ≥ 2 , see [7]. Incidentally, these lattices are arithmetic groups by a theorem of Margulis, and their finite quotients are subjected to stringent restrictions, namely the Congruence Subgroup Property (Serre’s conjecture on this subject is still incompletely resolved, see [9] for a short survey). In view of this historical background, and because of known rigidity properties of Kazhdan groups (see [1, Th. 1.2.5]), it is tempting to believe that property (T) yields restrictions on finite quotients on a general basis. For that reason, the construction of a Kazhdan group with finite simple quotients of Lie type and arbitrarily large rank, established by M. Kassabov in [6], came as a surprise. As of today, our knowledge of Kazhdan groups with large finite simple groups remain limited. Until recently, the only known family of Kazhdan groups mapping to $\text{Alt}(d)$ for infinitely many values of d is given by $\text{Aut}(F_n)$ for all $n \geq 4$ (see [5, 8] for property (T) and [8] for the alternating quotients).

In this talk, we presented another family of Kazhdan groups mapping having large finite simple quotients. Those groups have the additional feature of being Gromov hyperbolic. The following result describes some of them.

Theorem 1 (Caprace–Conder–Kaluba–Witzel [2]). *Let p be an odd prime. The group*

$$\mathcal{G}_p = \langle a, b, c \mid a^p, b^p, c^p, [a, b, b], [b, a, a], [c, a, c], [c, a, a, a], [c, a, a, c], [c, b, c], [c, b, b, b], [c, b, b, c] \rangle$$

is infinite hyperbolic.

For each $p \geq 7$, it has property (T) (while for $p = 3$ it does not).

For each $p \geq 3$, it maps onto $\text{SL}_{2d}(p)$ or $\text{Sp}_{2d}(p)$ for infinitely many d ’s.

The following result affords additional finite simple quotients of the group \mathcal{G}_p .

Theorem 2 (Caprace–Kassabov [3]). *For each prime $p \geq 7$ and each prime ℓ , the group \mathcal{G}_p maps onto $\text{Alt}((p^{3\ell} - p^3)/\ell)$.*

The proof of the latter indirectly relies on the Classification of the Finite Simple Groups (CFSG). Indeed, we show that \mathcal{G}_p maps onto the group of tame automorphisms of the polynomial ring $R = \mathbf{F}_p[X, Y, Z]$ generated by $\alpha: (X, Y, Z) \mapsto (X + Y, Y, Z)$, $\beta: (X, Y, Z) \mapsto (X, Y + Z, Z)$ and $\gamma: (X, Y, Z) \mapsto (X, Y, Z + X^2)$.

The group $\text{Aut}(R)$ is well known to be residually finite: finite quotients are afforded by permutation actions on the affine spaces k^3 for each finite extension k of \mathbf{F}_p . Indeed there is a natural identification $k^3 = \text{Hom}(R, k)$, and the group $\text{Aut}(R)$ acts on the latter set by precomposition. Observe that the $\text{Aut}(R)$ -action commutes with the natural $\text{Aut}(k)$ -action. Moreover, restricting the action from $\text{Aut}(R)$ to \mathcal{G}_p , one observes that the subset F^3 is stabilized for each intermediate field $\mathbf{F}_p \subseteq F \subseteq k$. A key point in the proof of Theorem 2 consists in showing that if $p \geq 7$ and if the degree $\ell = [k : \mathbf{F}_p]$ is prime, then the induced \mathcal{G}_p -action on the orbit space $(k^3 \setminus \mathbf{F}_p^3)/\text{Aut}(k)$ is 6-transitive. On the other hand, the CFSG implies that every 6-transitive subgroup of $\text{Sym}(m)$ contains $\text{Alt}(m)$. Since \mathcal{G}_p is generated by elements of order p , every permutation action consists of even permutations. The conclusion of Theorem 2 follows.

REFERENCES

- [1] B. Bekka, P. de la Harpe and A. Valette, *Kazhdan's property (T)*. New Mathematical Monographs, 11. Cambridge University Press, Cambridge, 2008.
- [2] P.-E. Caprace, M. Conder, M. Kaluba and S. Witzel, *Hyperbolic generalized triangle groups, property (T) and finite simple quotients*. Preprint (2020), arXiv:2011.09276.
- [3] P.-E. Caprace and M. Kassabov, *Tame automorphism groups or polynomial rings with property (T) and infinitely many alternating group quotients*. Preprint in preparation (2022).
- [4] R. Gilman, *Finite quotients of the automorphism group of a free group*. Canadian J. Math. **29** (1977), no. 3, 541–551.
- [5] M. Kaluba, D. Kielak and P. Nowak, *On property (T) for $\text{Aut}(F_n)$ and $\text{SL}_n(\mathbf{Z})$* . Ann. of Math. (2) **193** (2021), no. 2, 539–562.
- [6] *Universal lattices and unbounded rank expanders*. Invent. Math. **170** (2007), no. 2, 297–326.
- [7] D. Kazhdan, *On the connection of the dual space of a group with the structure of its closed subgroups*. Funct. Anal. Appl. **1** (1967), 63–65.
- [8] M. Nitsche, *Computer proofs for Property (T), and SDP duality*. Preprint (2020), arXiv:2009.05134.
- [9] M. S. Raghunathan, *The congruence subgroup problem*. Proc. Indian Acad. Sci. Math. Sci. **114** (2004), no. 4, 299–308.

A boundary for mapping class groups

URSULA HAMENSTÄDT

The *mapping class group* $\text{Mod}(S)$ of a closed surface S of genus $g \geq 2$ acts properly on the *Teichmüller space* $\mathcal{T}(S)$ of marked hyperbolic structures on S . This action is not cocompact, but the following result is due to Ji-Wolpert and Ji [3]. For its formulation, for $\epsilon > 0$ denote by $\mathcal{T}_\epsilon(S)$ the subspace of all marked hyperbolic structures whose *systole*, that is, a shortest closed geodesic, has length at least ϵ . This defines a manifold with corners, embedded in $\mathcal{T}(S)$.

Theorem 1 (Ji 2012). *For sufficiently small $\epsilon > 0$, the space $\mathcal{T}_\epsilon(S)$ is a $\text{Mod}(S)$ -equivariant deformation retract of $\mathcal{T}(S)$ on which $\text{Mod}(S)$ acts properly and cocompactly.*

As a consequence, for any torsion free subgroup Γ of $\text{Mod}(S)$ of finite index, $\mathcal{T}_\epsilon(S)$ is the universal covering of a classifying space for Γ .

Given these facts, it seems now natural to construct a compactification $\overline{\mathcal{T}}$ of $\mathcal{T}_\epsilon(S)$ on which $\text{Mod}(S)$ acts as a group of transformations and which captures topological and geometric properties of $\text{Mod}(S)$. Desirable properties of such a compactification with boundary $\mathcal{X} = \overline{\mathcal{T}} - \mathcal{T}_\epsilon(S)$ are as follows.

- (1) The space $\overline{\mathcal{T}}$ is compact and metrizable.
- (2) The action of $\text{Mod}(S)$ on \mathcal{X} is *minimal*, that is, every orbit is dense.
- (3) The action of $\text{Mod}(S)$ on \mathcal{X} is *topologically free*, that is, the interior of the fixed point set of any element of $\text{Mod}(S)$ different from the identity is empty.
- (4) The action of $\text{Mod}(S)$ is small for every open covering \mathcal{U} of $\overline{\mathcal{T}}$: If $K \subset \mathcal{T}_\epsilon(S)$ is any compact set, then for all but finitely many $g \in \text{Mod}(S)$, we have $gK \subset U$ for some $U \in \mathcal{U}$.
- (5) For every $x \in \mathcal{X}$ and every neighborhood U of x in $\overline{\mathcal{T}}$, there exists a neighborhood $V \subset U$ of x such that $V \cap \mathcal{T}_\epsilon(S)$ is contractible.

The purpose of the talk was to explain the following result [2].

Theorem 2. *There exists an explicit construction of a compactification of $\mathcal{T}_\epsilon(S)$ with properties (1)-(5).*

The boundary \mathcal{X} of this compactification contains the Gromov boundary $\partial\mathcal{C}(S)$ of the *curve graph* of S as a dense G_δ -subset.

An earlier construction of a boundary for $\text{Mod}(S)$ with properties (1)-(3) above is contained in [1]. Metrizability of this boundary is not established in [1] but was later shown by Hagen. The relation between these two constructions is unclear.

REFERENCES

- [1] M. Durham, M. Hagen, and A. Sisto, *Boundaries and automorphisms of hierarchically hyperbolic spaces*, *Geometry & Topology* 21 (2017), 3659–3758.
- [2] U. Hamenstädt, *A Z-structure for the mapping class group*, in preparation.
- [3] L. Ji, *Well rounded equivariant deformation retracts of Teichmüller space*, *L'Enseignement Math.* 60 (2014), 109–129.

Measure equivalence rigidity of $\text{Out}(F_N)$

CAMILLE HORBEZ

(joint work with Vincent Guirardel)

Measure equivalence was introduced by Gromov [7] as a measurable analogue of quasi-isometry. Two countable groups Γ_1, Γ_2 are *measure equivalent* if there exists a standard measure space Σ equipped with a measure-preserving action of $\Gamma_1 \times \Gamma_2$ by Borel automorphisms, such that for every $i \in \{1, 2\}$, the action of Γ_i on Σ is free and has a fundamental domain of finite measure. The space Σ is called a *measure equivalence coupling* between Γ_1 and Γ_2 . Crucially, any two lattices in the same locally compact second countable group G are measure equivalent (through their left/right action on $\Sigma = G$, equipped with its Haar measure). Also, if Γ_1, Γ_2 are

virtually isomorphic (there exist finite-index subgroups $\Gamma_i^0 \subseteq \Gamma_i$ and finite normal subgroups $F_i \trianglelefteq \Gamma_i^0$ such that $\Gamma_1^0/F_1 \approx \Gamma_2^0/F_2$), then they are measure equivalent.

Below F_N is a rank N free group, and $\text{Out}(F_N)$ is its outer automorphism group.

Theorem 1 ([6]). *Let $N \geq 3$, and let H be a countable group which is measure equivalent to $\text{Out}(F_N)$. Then H is virtually isomorphic to $\text{Out}(F_N)$.*

Furman proved that any countable group which is measure equivalent to a lattice in a higher-rank simple Lie group G , must be virtually isomorphic to a lattice in G [5]. Kida proved the measure equivalence superrigidity of most mapping class groups of finite-type orientable surfaces [10]. Theorem 1 is also not the first rigidity theorem about $\text{Out}(F_N)$: it was known that for $N \geq 3$, every automorphism of $\text{Out}(F_N)$ is inner (Bridson–Vogtmann [2], Khramtsov [9]), and in fact every automorphism between finite-index subgroups of $\text{Out}(F_N)$ is a conjugation (Farb–Handel [4] for $N \geq 4$, Horbez–Wade [8] for $N = 3$).

Many proofs of quasi-isometric rigidity of a finitely generated group G involve computing the group of self quasi-isometries of G . In analogy, an argument of Furman reduces the proof of measure equivalence rigidity to the study of self measure equivalence couplings of G . Theorem 1 is derived from the following statement: for every self measure equivalence coupling Σ of $\text{Out}(F_N)$, there exists an $(\text{Out}(F_N) \times \text{Out}(F_N))$ -equivariant measurable map $\Sigma \rightarrow \text{Out}(F_N)$ (where $\text{Out}(F_N)$ is equipped with the product action by left/right multiplication). Using techniques introduced by Furman, we derive from our work a rigidity theorem for lattice embeddings of $\text{Out}(F_N)$.

Corollary 2. *Let G be a locally compact second countable group, and let $\sigma : \text{Out}(F_N) \rightarrow G$ be a lattice embedding. Then there exists a continuous homomorphism $\pi : G \rightarrow \text{Out}(F_N)$ with compact kernel such that $\pi \circ \sigma = \text{id}$.*

Given a finitely generated group G , with a finite generating set S , the Cayley graph $\text{Cay}(G, S)$ is defined as the simple graph having one vertex per element of G , where two distinct vertices g, h are joined by an edge if there exists $s \in S$ such that $g = hs$ or $h = gs$. By viewing $\text{Out}(F_N)$ as a lattice in the automorphism group of its Cayley graph with respect to any finite generating set S , we deduce that every automorphism of $\text{Cay}(\text{Out}(F_N), S)$ is at bounded distance from the left multiplication by an element of $\text{Out}(F_N)$. We also derive the following statement.

Corollary 3. *Let $\Gamma \subseteq \text{Out}(F_N)$ be a torsion-free finite-index subgroup, and let S be a finite generating set of Γ . Then $\text{Aut}(\text{Cay}(\Gamma, S))$ embeds as a finite-index subgroup of $\text{Out}(F_N)$ that contains Γ (in particular it is countable).*

I will now describe some tools used in the proof of Theorem 1. For technical reasons, we work in the finite-index subgroup $\text{Out}^0(F_N)$ consisting of elements acting trivially in homology mod 3. Let $\Gamma_1 = \Gamma_2 = \text{Out}^0(F_N)$, and consider a self-coupling Σ , coming with an action of $\Gamma_1 \times \Gamma_2$. For simplicity, let us assume that the actions of Γ_1 and Γ_2 have a common fundamental domain Y . Then $Y \approx \Gamma_1 \backslash \Sigma \approx \Gamma_2 \backslash \Sigma$. Through these identifications, Y is equipped with two actions (of Γ_1 and

of Γ_2), and these two actions have the same orbits. The two actions determine a measured groupoid \mathcal{G} over Y , coming with two cocycles $\rho_1, \rho_2 : \mathcal{G} \rightarrow \text{Out}(F_N)$. To prove Theorem 1, it is in fact enough to show that the cocycles ρ_1, ρ_2 are *cohomologous*, i.e. there exists a measurable map $\varphi : Y \rightarrow \text{Out}(F_N)$, such that for almost every $g \in \mathcal{G}$ with source x and range y , one has $\rho_2(g) = \varphi(y)\rho_1(g)\varphi(x)^{-1}$.

We then take advantage of the rigidity of a combinatorial $\text{Out}(F_N)$ -graph, the *graph of nonseparating free splittings* \mathcal{S}_N . Its vertices are the decompositions $F_N = A*\{1\}$, considered up to equivariant homeomorphism of their Bass–Serre tree (equivalently, a vertex is determined by the conjugacy class of a corank one free factor A); two vertices are joined by an edge if there exists a two-edge graph of groups decomposition of F_N that collapses to both. A theorem of Pandit [11], building on earlier work of Bridson–Vogtmann [3], asserts that for $N \geq 3$, the natural map $\text{Out}(F_N) \rightarrow \text{Aut}(\mathcal{S}_N)$ is an isomorphism.

Our goal is now to build the map $\varphi : Y \rightarrow \text{Out}(F_N) \approx \text{Aut}(\mathcal{S}_N)$. Given a vertex $S \in V\mathcal{S}_N$, we consider the subgroupoid $\mathcal{H}_S^1 \subseteq \mathcal{G}$ made of all $g \in \mathcal{G}$ such that $\rho_1(g)$ fixes S . By considering the cocycle ρ_2 , one also defines a subgroupoid \mathcal{H}_S^2 . We prove that \mathcal{H}_S^1 is also, in an appropriate sense, a vertex stabilizer with respect to the cocycle ρ_2 : there exist a countable Borel partition $Y^* = \sqcup Y_{n,S}$ (which depends on S) of a conull Borel subset $Y^* \subseteq Y$, and for every n , a vertex $S_n \in V\mathcal{S}_N$, such that the restricted subgroupoids $(\mathcal{H}_S^1)_{|Y_n}$ and $(\mathcal{H}_{S_n}^2)_{|Y_n}$ coincide. This enables us to associate a map $V\mathcal{S}_N \rightarrow V\mathcal{S}_N$ for every $y \in Y$, sending S to S_n if $y \in Y_{n,S}$. In fact, almost everywhere, this map determines a graph automorphism of \mathcal{S}_N .

To prove the above statement, we characterize subgroupoids of \mathcal{G} that stabilize a vertex of \mathcal{S}_N in a purely groupoid-theoretic way, without referring to any cocycle. I will now present the group-theoretic version of this problem: how to characterize subgroups $H \subseteq \text{Out}(F_N)$ that preserve a corank one free factor A algebraically? If H is such a subgroup, it maps (by restriction) onto $\text{Out}(A)$. The kernel of this homomorphism has an index two subgroup isomorphic to $A \times A$, consisting of automorphisms that send a stable letter t of the HNN extension $F_N = A*\{1\}$ to $w_1^{-1}tw_2$ with $w_1, w_2 \in A$. We prove the following (partial) converse.

Proposition 4. *Let $H \subseteq \text{Out}^0(F_N)$ be a subgroup which contains a subgroup isomorphic to $K_1 \times K_2$, where each K_i is nonamenable and normal in H . Then H preserves the conjugacy class of a proper free factor.*

The next theorem is a key ingredient in our proof. It is an $\text{Out}(F_N)$ -analogue of Ivanov’s theorem associating a canonical decomposition of a finite-type connected, orientable surface S , to every subgroup H of its mapping class group, detecting the “active” parts of S for H . Likewise, our construction detects, in a sense, the “active” parts of F_N for a subgroup of automorphisms. The proof involves JSJ decompositions of groups and the dynamics of F_N -actions on arational trees.

Theorem 5. *Let $N \geq 2$, let $H \subseteq \text{Out}^0(F_N)$ be a nontrivial subgroup. If H fixes the conjugacy class of a proper free factor, so does its normalizer $N_{\text{Out}^0(F_N)}(H)$.*

To derive the above proposition, one lets H act on a hyperbolic $\text{Out}(F_N)$ -graph, the graph of free factors FF. If K_1 contains an infinite-order element φ

which fixes a free factor, then (by the above theorem) so do K_2 (which normalizes $\langle \varphi \rangle$) and H . Otherwise φ acts as a loxodromic isometry of FF, and its pair of fixed points at infinity is invariant under K_2 , which contradicts the non-amenability of K_2 using works of Bestvina–Reynolds and Hamenstädt describing $\partial_\infty \text{FF}$ in terms of arational F_N -trees. In the groupoid-theoretic version of this argument, the amenability of boundary point stabilizers is replaced by the amenability of the $\text{Out}(F_N)$ -action on $\partial_\infty \text{FF}$, proved jointly with Bestvina and Guirardel [1].

REFERENCES

- [1] M. Bestvina, V. Guirardel and C. Horbez, *Boundary amenability of $\text{Out}(F_N)$* , arXiv:1705.07017.
- [2] M. Bridson and K. Vogtmann, *Automorphisms of automorphism groups of free groups*, J. Algebra **229**(2) (2000), 785–792.
- [3] M. Bridson and K. Vogtmann, *The symmetries of outer space*, Duke Math. J. **106**(2) (2001), 391–409.
- [4] B. Farb and M. Handel, *Commensurations of $\text{Out}(F_n)$* , Publ. Math. Inst. Hautes Études Sci. **105** (2007), 1–48.
- [5] A. Furman, *Gromov’s measure equivalence and rigidity of higher-rank lattices*, Ann. of Math. (2) **150**(3) (1999), 1059–1081.
- [6] V. Guirardel and C. Horbez, *Measure equivalence rigidity of $\text{Out}(F_N)$* , arXiv:2103.03696
- [7] M. Gromov, *Asymptotic invariants of infinite groups*, Geometric group theory, Vol. 2 (Sussex, 1991), London Math. Soc. Lecture Notes Ser. **182** (1993), 1–295.
- [8] C. Horbez and R.D. Wade, *Commensurations of subgroups of $\text{Out}(F_N)$* , Trans. Amer. Math. Soc. **373**(4) (2020), 2699–2742.
- [9] D.G. Khramtsov, *Completeness of groups of outer automorphisms of free groups*, Group-theoretic investigations (1990), 128–143.
- [10] Y. Kida, *Measure equivalence rigidity of the mapping class group*, Ann. of Math.(2) **171**(3) (2010), 1851–1901.
- [11] S. Pandit, *The complex of non-separating embedded spheres*, Rocky Mountain J. Math. **44**(6) (2014), 2029–2054.

Random character varieties

EMMANUEL BREUILLARD

(joint work with Oren Becker, Péter Varjú)

We study the dimension and irreducibility of the G -character variety of a random group, where G is a semisimple Lie group. For example, we show that with an exponentially small probability of exceptions, for a random word w of length n , the word variety $\{(a, b) \in G, w(a, b) = 1\}$ is a non-empty finite set of G -conjugacy classes forming a single Galois orbit. The proofs are conditional on GRH and use uniform mixing of random walks and uniform expander bounds for $\bmod p$ quotients, which we establish along the way.

In more details: let G be a complex simply connected semisimple linear algebraic group defined over \mathbb{Q} , e.g. $G = SL_2(\mathbb{C})$. Given a tuple $\mathbf{w} = (w_1, \dots, w_r)$ of r words in k letters $x_1^{\pm 1}, \dots, x_k^{\pm 1}$, we consider the finitely presented group:

$$\Gamma_{\mathbf{w}} := \langle x_1, \dots, x_k \mid w_1 = \dots = w_r = 1 \rangle.$$

Its representation variety

$$\text{Hom}(\Gamma_{\mathbf{w}}, G) := \{(x_1, \dots, x_k) \in G^k, w_1(x_1, \dots, x_k) = \dots = w_r(x_1, \dots, x_k) = 1\}$$

is a closed algebraic subvariety of G^k , which is defined over \mathbb{Q} and invariant under conjugation by G . The subvariety $Z_{\mathbf{w}}$ of those $\rho \in \text{Hom}(\Gamma_{\mathbf{w}}, G)$ with Zariski-dense image in G is a Zariski-open subset.

We are interested in G -representations of a random group $\Gamma_{\mathbf{w}}$, where the words w_1, \dots, w_r are chosen to be independent with the same probability distribution obtained by spelling out ℓ letters $x_i^{\pm 1}$ independently at random with equal probability $\frac{1}{2k}$ to form each word. We show:

Theorem 1 (under GRH, [3]). *Fix G as above and $k \geq 2, r \geq 1$. There is $c > 0$ such that for all $\ell \geq 1$ the following holds with probability least $1 - e^{-c\ell}$ for a random r -tuple of words \mathbf{w}*

- (1) *If $r \geq k$, $Z_{\mathbf{w}}$ is empty,*
- (2) *If $r = k - 1$, then $Z_{\mathbf{w}}$ is finite non-empty and \mathbb{Q} -irreducible.*
- (3) *If $r \leq k - 2$, then $Z_{\mathbf{w}}$ is geometrically irreducible of dimension $(k - r) \dim G$.*

By the GRH here we mean the statement that all non-trivial zeroes of the Dedekind zeta functions of all algebraic number fields lie on the critical line.

Proofs are based on a double counting argument, where we compute the expected value of $|Z_{\mathbf{w}}(\mathbb{F}_p)|$ by combining the average over the tuples of words \mathbf{w} with an average over primes in a certain interval $[\frac{1}{2}T, T]$. The Lang-Weil estimates and the Chebotarev density theorem (see [5]) are crucial ingredients. So is the fact that random walks on Cayley graphs of $G(\mathbb{F}_p)$ are expanders (see [1]). In fact, to obtain the exponential decay of the probability of exceptions, it is essential to show that the spectral gap is uniform over all Cayley graphs of $\mathbb{G}(\mathbb{F}_p)$. We prove:

Theorem 2 ([4]). *Given k and $\epsilon > 0$ there is a subset \mathcal{B}_ϵ of all primes such that for all $T \geq 1$*

- (1) $|\mathcal{B}_\epsilon \cap [1, T]| \leq T^\epsilon,$
- (2) *the family of all k -regular Cayley graphs of $G(\mathbb{F}_p)$ for $p \notin \mathcal{B}_\epsilon$ is a family of expanders.*

This extends [2], where the result was proved for $G = SL_2$.

REFERENCES

[1] J. Bourgain and A. Gamburd, *Uniform expansion bounds for Cayley graphs of $SL_2(p)$* , Annals of Maths, 167, 2008.
 [2] E. Breuillard and A. Gamburd, *Strong uniform expansion in $SL_2(p)$* , GAFA, 20, 2010.
 [3] O. Becker, E. Breuillard, P. Varjú, *Random character varieties*, in preparation.
 [4] O. Becker, E. Breuillard, *Uniform spectral gaps and non-concentration estimates*, in preparation.
 [5] J-P. Serre, *Lectures on $N_X(p)$* , CRC Research Notes in Maths, 11, 2012.

Automorphisms and splittings of special groups

ELIA FIORAVANTI

The automorphism group of a finitely generated group G can sometimes be described quite explicitly in terms of amalgamated-product and HNN splittings of G over a family of subgroups. Hyperbolic groups are the most classical instance of this phenomenon, due to old breakthroughs of Rips and Sela [9].

Theorem (Rips–Sela). *Let G be a (torsion-free) Gromov-hyperbolic group. A finite-index subgroup of $\text{Out}(G)$ is generated by finitely many Dehn twists with respect to splittings of G over cyclic subgroups.*

The original proof of this result is extremely general. Hyperbolicity of G is only needed to construct nice G -actions on \mathbb{R} -trees, after which one only needs tools from Rips Theory, which apply to general finitely presented groups.

Based on this, it is reasonable to expect that similar tools can be used to study automorphisms of much broader classes of groups. Relatively hyperbolic groups have received a lot of attention in this direction [3, 6], but groups with weaker hyperbolic features have remained largely unexplored¹.

At the same time, there is evidence that many non-relatively-hyperbolic groups should also exhibit strong connections between their automorphisms and splittings.

An excellent example of this is provided by right-angled Artin groups A_Γ . Similar to the situation for hyperbolic groups, a finite-index subgroup of $\text{Out}(A_\Gamma)$ is generated by finitely many Dehn twists — the Laurence–Servatius generators [8] known as partial conjugations and transvections.

An important difference, however, is that these Dehn twists correspond to splittings over rather large subgroups A_Γ . In fact, it is easy to construct examples where $\text{Out}(A_\Gamma)$ is infinite, but A_Γ does not split over any (virtually) abelian subgroups.

In view of these observations, it is natural to wonder what can be said on the groups $\text{Out}(G)$ for general *special* groups G , in the Haglund–Wise sense [7]. On the one hand, special groups share many similarities with right-angled Artin groups. On the other, they form a much broader and more mysterious class of groups, and it is not known if $\text{Out}(G)$ is always finitely generated at this level of generality.

Our main theorem is a weaker analogue of the Rips–Sela theorem in this setting, which nevertheless demonstrates how splittings over abelian subgroups naturally need to be replaced with splittings over *centralisers*.

Theorem 1 ([2]). *Let G be a special group. Then $\text{Out}(G)$ is infinite if and only if it contains an infinite-order Dehn twist with respect to a splitting $G = A *_C B$ or $G = A *_C$, where:*

- (a) *either C is the centraliser of a finite subset of G ;*
- (b) *or C is the kernel of a homomorphism $Z \rightarrow \mathbb{Z}$, where Z is the centraliser of a single element of G .*

¹However, a new approach due to Sela and based on *weakly acylindrical* actions on hyperbolic spaces promises to change this. See [10] for some preliminary results.

Note that Case (b) cannot be avoided in the previous theorem: there are examples of right-angled Artin groups A_Γ such that $\text{Out}(A_\Gamma)$ is infinite, but A_Γ admits no splittings over centralisers of finite subsets.

It is also interesting to study the *coarse-median preserving* subgroup of $\text{Out}(G)$. To define this, note that the group $\text{Out}(G)$ acts on the space of all coarse median structures on G . Special groups are endowed with natural coarse median structures arising from their (quasi-convex) embeddings into right-angled Artin groups, so, fixing one such structure $[\mu]$, we can consider its stabiliser $\text{Out}(G, [\mu]) \leq \text{Out}(G)$.

The subgroup $\text{Out}(G, [\mu])$ tends to display closer similarities to automorphism groups of hyperbolic groups than the whole $\text{Out}(G)$. For instance, when G is hyperbolic, there is only one coarse median structure on G , hence $\text{Out}(G, [\mu]) = \text{Out}(G)$. Instead, when $(G, [\mu])$ is a right-angled Artin group equipped with the coarse median structure induced by the Salvetti complex, $\text{Out}(G, [\mu])$ is the group of *untwisted automorphisms* previously studied by Charney–Stambaugh–Vogtmann [1].

As it turns out, the group $\text{Out}(G, [\mu])$ has an even simpler relation to the splittings of G .

Theorem 2 ([2]). *Let $(G, [\mu])$ be a special group with an induced coarse median structure. Then $\text{Out}(G, [\mu]) \leq \text{Out}(G)$ is infinite if and only if it contains an infinite-order Dehn twist with respect to a splitting as in Case (a) of Theorem 1.*

Theorems 1 and 2 are proved by analysing some natural G -actions on \mathbb{R} -trees and exploiting tools from Rips theory (especially the work of Guirardel [4, 5]).

More precisely, to every right-angled Artin group A_Γ and every vertex $v \in \Gamma$, we can associate a natural action on a simplicial tree $A_\Gamma \curvearrowright T_v$. This is the Bass–Serre tree of the HNN splitting of A_Γ with vertex group $A_{\Gamma-\{v\}}$ and stable letter v . Embedding the special group G into some right-angled Artin group A_Γ , we obtain a proper G -action on the finite product $\prod_{v \in \Gamma} T_v$.

The \mathbb{R} -trees involved in the proof of Theorems 1 and 2 are limits T_v^ω of copies of the T_v , suitably rescaled and twisted by automorphisms of G . The core of the proof lies in analysing arc-stabilisers for the limit actions $G \curvearrowright T_v^\omega$ and showing that they are centralisers (or closely related subgroups). This is extremely delicate because arc-stabilisers for the actions $G \curvearrowright T_v$ are not “algebraically meaningful” subgroups of G (unlike abelian subgroups), so we do not have any control on their images under automorphisms of G .

Their key result to overcome these issues is the following.

Theorem 3. *Fix an embedding $G \hookrightarrow A_\Gamma$ and some $v \in \Gamma$. Then sufficiently long arcs in T_v can be perturbed so that their G -stabiliser becomes a centraliser in G .*

Now, automorphisms of G will certainly take centralisers to centralisers, which allows us to suitably characterise arc-stabilisers of the limit trees T_v^ω .

REFERENCES

[1] R. Charney, N. Stambaugh, K. Vogtmann, *Outer space for untwisted automorphisms of right-angled Artin groups*, *Geom. Topol.* 21 (2017), no. 2, 1131–1178.
 [2] E. Fioravanti, *On automorphisms and splittings of special groups*, arXiv:2108.13212, 2021.

- [3] D. Groves, *Limit groups for relatively hyperbolic groups. I. The basic tools*, Algebr. Geom. Topol. 9 (2009), no. 3, 1423–1466.
- [4] V. Guirardel, *Approximations of stable actions on \mathbb{R} -trees*, Comment. Math. Helv. 73 (1998), no. 1, 89–121.
- [5] V. Guirardel, *Actions of finitely generated groups on \mathbb{R} -trees*, Ann. Inst. Fourier (Grenoble) 58 (2008), no. 1, 159–211.
- [6] V. Guirardel, G. Levitt, *Splittings and automorphisms of relatively hyperbolic groups*, Groups Geom. Dyn. 9 (2015), no. 2, 599–663.
- [7] F. Haglund, D. T. Wise, *Special cube complexes*, Geom. Funct. Anal. 17 (2008), no. 5, 1551–1620.
- [8] M. R. Laurence, *A generating set for the automorphism group of a graph group*, J. London Math. Soc. (2) 52 (1995), no. 2, 318–334.
- [9] E. Rips, Z. Sela, *Structure and rigidity in hyperbolic groups. I*, Geom. Funct. Anal. 4 (1994), no. 3, 337–371.
- [10] Z. Sela, *Automorphisms of Groups and a Higher Rank JSJ Decomposition I: RAAGs and a Higher Rank Makanin-Razborov Diagram*, arXiv:2201.06320, 2022.

Boundary rigidity of groups acting on products of trees

BAKUL SATHAYE

(joint work with Kasia Jankiewicz, Annette Karrer, and Kim Ruane)

The *visual boundary* of a CAT(0) metric space is defined as the set of equivalence classes of asymptotic rays endowed with the cone topology. For hyperbolic spaces X and Y , any quasi-isometry $X \rightarrow Y$ between them extends to a homeomorphism of their visual boundaries. Consequently, the homeomorphism type of the boundary of a hyperbolic group is a well-defined group invariant. This is not true for CAT(0) groups, i.e. groups that act geometrically on CAT(0) spaces.

Bowers-Ruane give an example of a group G acting geometrically on CAT(0) spaces X and Y , such that the associated G -equivariant quasi-isometry between the spaces does not extend to a homeomorphism between their visual boundaries [1]. Croke-Kleiner provided an example of a CAT(0) group G and two CAT(0) spaces X, Y , both admitting geometric actions by G such that ∂X and ∂Y are non-homeomorphic [4]. Wilson further showed that in fact this same G acts geometrically on uncountably many spaces with boundaries of distinct topological type [11]. This group G is the right-angled Artin group with the defining graph a path on four vertices.

A CAT(0) group G is called *boundary rigid* if the visual boundaries of all CAT(0) spaces admitting a geometric action by G are homeomorphic. As noted above, hyperbolic CAT(0) groups are boundary rigid while not all CAT(0) groups are boundary rigid. Ruane proved that the direct product of hyperbolic groups is boundary rigid [9]. Hosaka extended that to show that any direct product of boundary rigid groups is boundary rigid [6]. Hruska-Kleiner proved that groups acting geometrically on CAT(0) spaces with the isolated flats property are boundary rigid [7].

A *bushy tree* is an infinite tree of bounded valence with no terminal vertices. We study a family of CAT(0) groups acting geometrically on the product of two

bushy trees. We will assume the groups preserve the factors, which is always the case after passing to an index 2 subgroup. We refer to such groups as *(cocompact) lattices in a product of trees*. We are interested in the following question:

Question. Are lattices in a product of trees boundary rigid?

The simplest example of a lattice in a product of trees is a direct product $F_n \times F_m$ of two finite rank free groups. These are boundary rigid by [9]. However, there exist lattices in product of trees that are *irreducible*, i.e. they do not split as direct products, even after passing to a finite index subgroup. Irreducible lattices in products of trees were studied by Burger-Mozes [2], [3] and by Wise [10].

We give the positive answer to the above for torsion-free lattices.

Theorem 1. *Let G be a torsion-free lattice in a product of trees. Suppose G acts geometrically on a $CAT(0)$ space X . Then ∂X is the join $\mathcal{C} * \mathcal{C}$ of two copies of the Cantor set.*

Moreover, if X is geodesically complete, then X splits as a product of $CAT(0)$ spaces $X_1 \times X_2$, where $\partial X_i = \mathcal{C}$ for each $i = 1, 2$.

If the action of G on $T_1 \times T_2$ is vertex-transitive, then G admits a particularly nice presentation and it is always virtually torsion-free.

Corollary 2. *Every (not necessarily torsion-free) vertex-transitive lattice in a product of trees is boundary rigid.*

There are two major steps in the proof of the theorem. We first show that ∂X splits as a join of two 0-dimensional subspaces and then show that each subspace is homeomorphic to \mathcal{C} .

To show ∂X splits as a join, it suffices to show that $\partial_T X$, the Tits boundary of X , splits as a metric join of two discrete sets. In our setting, this will provide a quasi-dense subset X' of X which splits isometrically as a product $X_1 \times X_2$. This is enough to conclude that the visual boundary ∂X splits as $\partial X_1 * \partial X_2$, with each factor 0-dimensional.

Once we have this information about ∂X , we prove that $\partial X_i = \mathcal{C}$ for $i = 1, 2$. This step is non-trivial when G is irreducible.

In the special case when X is a $CAT(0)$ cube complex and the action of G is essential (or X has the geodesic extension property instead of essential action), the Rank Rigidity theorem of Caprace-Sageev allows us to get the splitting of ∂X as a join of 0-dimensional subspaces almost immediately.

REFERENCES

- [1] P.L. Bowers and K. Ruane, *Boundaries of nonpositively curved groups of the form $G \times \mathbf{Z}^n$* , Glasgow Math. J. **38** (2) (1996), 177–189.
- [2] M. Burger and S. Mozes, *Finitely presented simple groups and products of trees*, C. R. Acad. Sci. Paris Sér. I Math., **324** (7) (1997), 747–752.
- [3] M. Burger and S. Mozes, *Lattices in product of trees*, Inst. Hautes Études Sci. Publ. Math., **92** (2000), 151–194.
- [4] C.B. Croke and B. Kleiner, *Spaces with nonpositive curvature and their ideal boundaries*, Topology, **39** (3) (2000), 549–556.

- [5] D.P. Guralnik and E.L. Swenson, *A ‘transversal’ for minimal invariant sets in the boundary of a CAT(0) group*, Trans. Amer. Math. Soc., **365** (6) (2013), 3069–3095.
- [6] T. Hosaka, *A splitting theorem for CAT(0) spaces with the geodesic extension property*, Tsukuba J. Math., **27** (2) (2003), 289–293.
- [7] G.C. Hruska and B. Kleiner, *Hadamard spaces with isolated flats*, With an appendix by the authors and Mohamad Hindawi, Geom. Topol., **9** (2005), 1501–1538.
- [8] R. Ricks, *Boundary conditions detecting product splittings of CAT(0) spaces*, Groups Geom. Dyn., **14** (1) (2020), 283–295.
- [9] K.E. Ruane, *Boundaries of CAT(0) groups of the form $\Gamma = G \times H$* , Topology Appl., **92** (2), (1999), 131–151.
- [10] D.T. Wise, *Non-positively curved squared complexes, aperiodic tilings, and non-residually finite groups*, PhD Thesis, Princeton University (1996)
- [11] J.M. Wilson, *A CAT(0) group with uncountably many distinct boundaries*, J. Group Theory, **8** (2) (2005), 229–238.

Rates of growth of acylindrically hyperbolic groups

KOJI FUJIWARA

(joint work with Zlil Sela)

Let G be a finitely generated group with a finite generating set S . Let $B_n(G, S)$ be the set of elements in G whose word lengths are at most n with respect to the generating set S . Let $\beta_n(G, S) = |B_n(G, S)|$. The *exponential growth rate* of (G, S) is defined to be:

$$e(G, S) = \lim_{n \rightarrow \infty} \beta_n(G, S)^{\frac{1}{n}}.$$

A f.g. group G has *exponential growth* if there exists a finite generating set S such that $e(G, S) > 1$. We define:

$$e(G) = \inf_{|S| < \infty} e(G, S),$$

where the infimum is taken over all the finite generating sets S of G .

Given a f.g. group G we further define the following set in \mathbb{R} :

$$\xi(G) = \{e(G, S) \mid |S| < \infty\},$$

where S runs over all the finite generating sets of G . The set $\xi(G)$ is always countable.

It is proved in [FS] that if G is a non-elementary hyperbolic group then $\xi(G)$ is well-ordered (hence, in particular, has a minimum); the ordinal of $\xi(G)$ is at least ω^ω ; for each $r \in \xi(G)$ there are only finitely many S with $e(G, S) = r$ up to $\text{Aut}(G)$.

I will outline the proof of the well-orderedness of $\xi(G)$ for hyperbolic groups, then discuss the following generalization obtained in [F]: Suppose a f.g. group G acts on a δ -hyperbolic graph X *acylindrically*, and the action is non-elementary. Assume that there exists a constant M such that for any finite generating set S of G , S^M contains a hyperbolic element on X . Assume that G is *equationally Noetherian*. Then, $\xi(G)$ is a well-ordered set. In particular, $e(G)$ is realized by some S . This result covers all (non-uniform) lattices in a rank-1 simple Lie groups as examples.

REFERENCES

- [FS] K.Fujiwara, Z.Sela. The rates of growth in a hyperbolic group. preprint. 2020. arXiv:2002.10278
- [F] K.Fujiwara, The rates of growth in an acylindrically hyperbolic group, preprint. 2021. arXiv:2103.01430

Isoperimetric inequalities in finitely generated groups

DENIS OSIN

To each finitely generated group G , we associate a quasi-isometric invariant called the *isoperimetric spectrum* of G . If G is finitely presented, our invariant is closely related to the Dehn function of G . The main goal of this paper is to initiate the study of isoperimetric spectra of finitely generated (but not necessarily finitely presented) groups. In particular, we show that the isoperimetric spectrum of small cancellation groups, certain wreath products, and free Burnside groups of sufficiently large odd exponent is “linear” in a certain precise sense, i.e., behaves exactly like the isoperimetric spectrum of hyperbolic groups. We also address some natural questions on the structure of the poset of isoperimetric spectra. As an application, we prove that there exist 2^{\aleph_0} pairwise non-quasi-isometric finitely generated groups of finite exponent. This talk is based on joint work with K. Rybak [1].

REFERENCES

- [1] D. Osin, K. Rybak, Isoperimetric inequalities in finitely generated groups, *arXiv:2203.12518*.

Markov chains on groups and quasi-isometries

ALESSANDRO SISTO

(joint work with Antoine Goldsborough)

Random walks on groups provide a model for a “generic” element of a group, and they are very interesting and very well-studied from several points of view.

A lot of geometric group theory revolves around studying groups quasi-isometric to each other, and in this context it is natural to study what one can say about random walks on quasi-isometric groups. Unfortunately, however, random walks are not compatible with quasi-isometries, in the sense that they cannot be “pushed forward” via quasi-isometries in any meaningful sense.

To resolve this, Antoine Goldsborough and I proposed the study of more general Markov processes on groups that are indeed “quasi-isometry compatible”, which we call *tame Markov chains*. We studied such Markov chains on two classes of groups which include:

- non-elementary hyperbolic and relatively hyperbolic groups,
- acylindrically hyperbolic 3-manifold groups,
- right-angled Artin groups whose defining graph is a tree of diameter at least 3,

- groups acting acylindrically and non-elementarily on a tree with nilpotent and undistorted edge stabilisers.

Let us call the classes \mathcal{C}_1 and \mathcal{C}_2 ; for this abstract it does not matter much what these are exactly, just that they contain a variety of examples as illustrated above.

Using tame Markov chains, we proved a central limit theorem for random walks on groups quasi-isometric to groups in the classes \mathcal{C}_i , namely:

Theorem: ([3]) Let G be a group quasi-isometric to a group in \mathcal{C}_1 or \mathcal{C}_2 (e.g. one of the groups listed above). Fix a word metric d_G on G , and let (Z_n) be a simple-random walk on G . Then there exist constants $L, \sigma > 0$ such that we have the following convergence in distribution:

$$\frac{d_G(1, Z_n) - Ln}{\sigma^2 \sqrt{n}} \rightarrow \mathcal{N}(0, 1),$$

where $\mathcal{N}(0, 1)$ denotes the normal distribution with mean 0 and variance 1.

The interest of this theorem is that the assumption is only that the group G is *quasi-isometric* to a group we know about, while the conclusion is a strong conclusion about random walks.

The main technical result we proved towards the theorem is a version of a result of Maher-Tiozzo [1] for random walks on groups acting non-elementarily on a hyperbolic space. This result says that random walks make linear progress on the space being acted upon, and we show the same result for tame Markov chains, rather than random walks, for groups from \mathcal{C}_1 and \mathcal{C}_2 (each of which comes with an action on a hyperbolic space). Our proof is rather different from Maher-Tiozzo's, or any other proof of similar results in the literature, and indeed we require more geometric input. This is where we need additional assumptions other than just a group acting non-elementarily on a hyperbolic space.

However, for any group where linear progress for tame Markov chains holds (e.g. groups from \mathcal{C}_1 and \mathcal{C}_2), we can use known arguments from the random walks literature to deduce various consequences. In particular, we can use methods of Mathieu and myself [2] to deduce that Markov paths stay close to quasi-geodesics, in a suitable sense. In the setup of the main theorem, this says that sample paths of the random walk on G stay close to geodesics, and at that point we can use a criterion for the central limit theorem from the aforementioned paper [2].

REFERENCES

- [1] J. Maher and G. Tiozzo, *Random walks on weakly hyperbolic groups*, J. Reine Angew. Math. **742** (2018), 187–239.
- [2] P. Mathieu and A. Sisto, *Deviation inequalities for random walks*, Duke Math. J. **169** (2020), 961–1036.
- [3] A. Goldsborough and A. Sisto, *Markov chains on hyperbolic-like groups and quasi-isometries*, Arxiv.

A new proof of best slope homological stability for mapping class groups of surfaces

NATHALIE WAHL

(joint work with Oscar Harr and Max Vistруп)

Suppose that $\{G_n\}_{n \in \mathbb{N}}$ is a collection of groups equipped with a sum

$$G_n \times G_m \xrightarrow{\oplus} G_{n+m}$$

and with compatible homomorphisms $\phi_n : B_n \rightarrow G_n$ from the braid groups; such homomorphisms are determined, using the sum \oplus , by a single element $b \in G_2$ that satisfies the braid relations. We will consider here the associated sequence of groups

$$G_1 \xrightarrow{\oplus 1} G_2 \xrightarrow{\oplus 1} \dots$$

obtained by summing with the identity element $1 \in G_1$. We will assume for simplicity that these maps are injective.

Theorem 1. [9, Thm A][6, Sec 7] *Given $(\{G_n\}_{n \in \mathbb{N}}, \oplus, b)$ as above, there exists for each n a semi-simplicial set W_n with an action of G_n that is transitive on p -simplices for all p and with stabilizers $Stab(\sigma_p) \cong G_{n-p-1}$. If there exists a $k \geq 2$ such that W_n is $\binom{n-2}{k}$ -connected, then*

$$H_i(G_n; \mathbb{Z}) \xrightarrow{\oplus 1} H_i(G_{n+1}; \mathbb{Z})$$

is a surjection for all $i \leq \frac{n}{k}$, and an isomorphism for all $i \leq \frac{n-1}{k}$.

One can think of G_n as the automorphism group of an object “ $X^{\oplus n}$ ” in a monoidal category. For $X = V$ a vector space we could take $G_n = \text{GL}(V^n)$ while G_n could be a mapping class group if X is instead a surface. The map $G_n \rightarrow G_{n+1}$ is obtained by adding the identity on X and $b : X \oplus X \rightarrow X \oplus X$ is a morphism that “switches the X ’s”. (See [12] for an introduction for this point of view on homological stability.)

We are here interested in the group $G_g = \pi_0 \text{Diff}(S_{g,1})$, the mapping class group of a surface $S_{g,1}$ of genus g with one boundary component fixed by the mapping class. Take $X = S_{1,1}$ a surface of genus 1, and consider the map

$$\pi_0 \text{Diff}(S_{g,1}) \times \pi_0 \text{Diff}(S_{h,1}) \xrightarrow{\oplus} \pi_0 \text{Diff}(S_{g+h,1})$$

induced by boundary connected sum of the surfaces

$$S_{g,1} \oplus S_{h,1} := S_{g,1} \cup_I S_{h,1} \cong S_{g+h,1},$$

that is gluing the surfaces along an interval I in their boundary. Taking $b \in \pi_0 \text{Diff}(S_{2,1})$ a half-twist along a boundary-parallel circle as shown in Figure 1, one can check that the space W_g given by the theorem identifies with the tethered chains of Hatcher-Vogtmann [5], see [9, Sec 5.6]. It follows from [5] that W_g is $\binom{g-3}{2}$ -connected. Applying the theorem, this gives homological stability for the mapping class groups $\pi_0 \text{Diff}(S_{g,1})$ in the range $i \leq \frac{g-2}{2}$, which however is known not to be optimal [2].

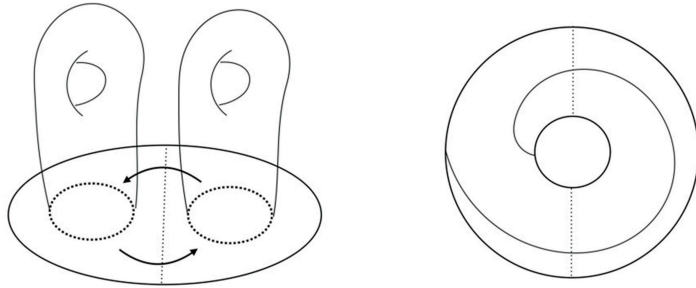

FIGURE 1. braid $b \in \pi_0 \text{Diff}(S_{1,1} \oplus S_{1,1})$ and $b' \in \pi_0 \text{Diff}(D^2 \oplus' D^2)$

In this talk, we explain how our chosen $X = S_{1,1}$ can be decomposed as a sum using the building block $D = (D^2, I_0, I_1)$, a disc with two intervals marked in its boundary, and the sum \oplus' that now glues along two intervals instead of one. Indeed, this sum gives $D^{\oplus' 2g+1} \cong S_{g,1}$ and $D^{\oplus' 2g+2} \cong S_{g,2}$, and we have factorized our old stabilisation map as the composition of two maps:

$$\pi_0 \text{Diff}(S_{g,1}) \xrightarrow{\oplus' D} \pi_0 \text{Diff}(S_{g,2}) \xrightarrow{\oplus' D} \pi_0 \text{Diff}(S_{g+1,1}).$$

For the braiding, we take the element

$$b' \in G_2 = \pi_0 \text{Diff}(D \oplus' D) = \pi_0 \text{Diff}(S^1 \times I)$$

given by the Dehn twist along the middle circle in the cylinder, as depicted in Figure 1. The corresponding map $B_{2g+i} \rightarrow \pi_0 \text{Diff}(S_{g,i})$ is in this case the geometric embedding of the braid group with image the subgroup generated by the Dehn twists on a chain of embedded circles [1, 13], see also [10]. We show in [4] that the space W_n associated to this data by the above theorem identifies with the “disordered arc complex”, a simplicial complex of collections of disjointly embedded, non-separating arcs between two points b_0 and b_1 in the boundary of the surface, such that the ordering of the arcs at b_0 and b_1 agree.

Proposition 2. [4] *The disordered arc complex W_n is $\frac{n-5}{3}$ -connected.*

Applying the above theorem, we immediately get the following corollary.

Corollary 3. *The stabilization map*

$$H_i(\pi_0 \text{Diff}(S_{g,1})) \xrightarrow{\cong} H_i(\pi_0 \text{Diff}(S_{g+1,1}))$$

is an isomorphism in the range $i \leq \frac{2g-3}{3}$.

This range is $\frac{1}{3}$ off the best known range as given in [2], see also [3, 8, 11]. Note that the slope $\frac{2}{3}$ is known to be optimal by [7, Thm 1.1]. One can in addition deduce a stability result with twisted coefficients, see [9, Thm A] and [6, Thm C].

REFERENCES

- [1] J. Birman and B. Wajnryb, *Presentations of the mapping class group*. Errata. Israel J. Math. 88, 425–427 (1994).
- [2] S.K. Boldsen, *Improved homological stability for the mapping class group with integral or twisted coefficients*. Math. Z. 270 (2012), no. 1-2, 297–329.
- [3] S. Galatius, A. Kupers and O. Randal-Williams, *E2-cells and mapping class groups*. Publ. Math. Inst. Hautes Études Sci. 130 (2019), 1-61.
- [4] O. B. Harr, M. Vistrup and N. Wahl, *Disordered arcs and Harer stability*. In preparation.
- [5] A. Hatcher and K. Vogtmann, *Tethers and homology stability for surfaces*. Algebr. Geom. Topol. 17 (2017), no. 3, 1871–1916.
- [6] M. Krannich *Homological stability of topological moduli spaces*. Geom. Topol. 23 (2019), no. 5, 2397–2474.
- [7] S. Morita, *Generators for the tautological algebra of the moduli space of curves*, Topology 42 (2003), 787-819.
- [8] O. Randal-Williams, *Resolutions of moduli spaces and homological stability*. J. Eur. Math. Soc. (JEMS), 18(1):181, 2016.
- [9] O. Randal-Williams and N. Wahl, *Homological stability for automorphism groups*. Adv. Math. 318 (2017), 534–626.
- [10] Y. Song and U. Tillmann, *Braids, mapping class groups, and categorical delooping*. Math. Ann. 339 (2007), no. 2, 377–393.
- [11] N. Wahl, *Homological stability for mapping class groups of surfaces*, in Handbook of Moduli. Vol. III, Adv. Lect. Math. (ALM), vol. 26, pp. 547–583, International Press, Somerville, 2013.
- [12] N. Wahl, *Homological stability: a tool for computations*. To appear in the Proceedings of the 2022 ICM.
- [13] B. Wajnryb, *A simple presentation for the mapping class group of an orientable surface*. Israel J. Math. 45, 157–174 (1983).

Subgroups of hyperbolic groups of type F_3 and not F_4

CLAUDIO LLOSA ISENRIK

(joint work with Bruno Martelli, Pierre Py)

Introduced by Gromov in his seminal 1987 essay [4], the class of hyperbolic groups is an important class of finitely generated groups that attracts much interest in geometric group theory. Hyperbolic groups are known to enjoy many nice properties. For instance, they have linear Dehn function, solvable word and conjugacy problem, no \mathbb{Z}^2 -subgroups, and every hyperbolic group has a classifying space, a $K(G, 1)$, which is a CW-complex with finitely many cells in each dimension. It is natural to ask which properties of hyperbolic groups are inherited by all of their subgroups. While some of the aforementioned properties clearly pass to subgroups, for others this is not clear and raises challenging problems.

In 1982 Rips [14] proved that there are subgroups of hyperbolic groups which are finitely generated and not finitely presented. In particular, such subgroups can not be themselves hyperbolic. In [4], Gromov asserted the existence of finitely presented subgroups of hyperbolic groups, which are not themselves hyperbolic. The first such examples were constructed by Brady [1] in 1999. More precisely, Brady proved the existence of subgroups of hyperbolic groups which are of finiteness type F_2 and not F_3 , and more examples of this form were constructed subsequently by

Lodha [12] and Kropholler [9]. Here we call a group of finiteness type F_k if it has a classifying space with finite k -skeleton. This generalises finite generability (resp. finite presentability), which are equivalent to type F_1 (resp. type F_2). Finally, very recently, Italiano, Martelli and Migliorini [6] proved the existence of non-hyperbolic finitely presented subgroups of hyperbolic groups which have a finite classifying space, solving a fundamental open problem.

Brady's work raises the natural

Question 1 (Brady [1]). *Let $n \geq 3$ be an integer. Is there a subgroup $H < G$ of a hyperbolic group G which is of type F_n and not of type F_{n+1} ?*

In my talk I present a positive answer to Brady's question for $n = 3$.

Theorem 2 ([10, Theorem 1]). *There is a hyperbolic group G which has a subgroup $H < G$ of finiteness type F_3 and not F_4 .*

To obtain our examples we start from a finite volume real hyperbolic 8-manifold $M^8 = \mathbb{H}_{\mathbb{R}}^8/\Gamma$, where $\Gamma < SO(8, 1)$ is a certain non-uniform lattice; M^8 is obtained from a right-angled Coxeter polytope. In [5], Italiano, Martelli and Migliorini prove that M^8 admits a continuous map $f : M^8 \rightarrow S^1$ to the circle such that the kernel $\ker(f_*)$ of the induced map on fundamental groups is of type F_3 . To obtain this result, they use that Γ is a cubulable finite index subgroup of a right-angled Coxeter group and apply Bestvina–Brady Morse theory. On the other hand it follows from a theorem of Lück [13] and the non-vanishing of the 4th ℓ^2 -Betti number of $\pi_1(M^8)$ that $\ker(f_*)$ is not of type F_4 . Thus, $\ker(f_*)$ is a group of type F_3 , but not F_4 , which is a subgroup of Γ , and the latter is relatively hyperbolic with respect to a family of parabolic \mathbb{Z}^7 -subgroups, corresponding to the (toric) cusps of M^8 .

To obtain the desired subgroups of hyperbolic groups, we now proceed in three steps. First we prove that there is a small perturbation $\tilde{f} : M^8 \rightarrow S^1$ of f with the property that $\ker(\tilde{f}_*)$ is still of type F_3 and not F_4 and such that there is no torus cusp section $T^7 \hookrightarrow M^8$ on which the restriction of \tilde{f} is homotopic to a constant map. Then we apply a result of Fujiwara–Manning [3] to obtain a Dehn filling \overline{M}^8 of a finite cover of M^8 which is CAT(-1) and a finite CW-complex; the non-triviality of \tilde{f} on torus cusp sections implies that \tilde{f} induces a map $\overline{f} : \overline{M}^8 \rightarrow S^1$ with $\ker(\overline{f}_*)$ of type F_3 . Finally, we use homological arguments to prove that $H_4(\ker(\overline{f}_*), \mathbb{Q})$ is not finite dimensional and therefore $\ker(\overline{f}_*)$ is not of type F_4 .

Our approach generalises to higher dimensions in the following sense. Assume that we can find a non-uniform lattice $\Lambda < SO(2n, 1)$ together with a homomorphism $\Lambda \rightarrow \mathbb{Z}$, which has kernel of type F_{n-1} and is induced by a continuous map $M^{2n} := \mathbb{H}^{2n}/\Lambda \rightarrow S^1$ which is not homotopic to a constant map on any torus cusp section $T^{2n-1} \hookrightarrow M^{2n}$. Then we could apply the same techniques of Dehn filling suitable finite covers of M^{2n} to construct subgroups of hyperbolic groups which are of type F_{n-1} , but not of type F_n . Note that for uniform lattices the cusp condition is empty and we do not have to perform a Dehn filling, since Λ is already hyperbolic. This discussion raises the:

Question 3. Let $\Lambda < SO(2n, 1)$ be a lattice. Is there a finite index subgroup $\Lambda_0 < \Lambda$ and a homomorphism $\phi : \Lambda_0 \rightarrow \mathbb{Z}$ with kernel of type F_{n-1} , but not F_n ?

Currently, we only have examples of such lattices for $n \in \{1, 2, 4\}$ and for $n = 4$ only in the non-uniform case. However, we suspect that they exist in all dimensions. Evidence for this is provided by Fisher's recent proof [2] of a conjecture of Kielak [7, 8] about finiteness properties of kernels of virtual algebraic fibrations of RFRS groups. Indeed, one consequence of this and the existence of RFRS lattices in $SO(2n, 1)$ is:

Proposition 4 ([10, Proposition 19]). *For all $n \geq 1$, there is a uniform lattice $\Lambda < SO(2n, 1)$ and a homomorphism $\phi : \Lambda \rightarrow \mathbb{Z}$, such that $\ker(\phi)$ is of finiteness type $FP_{n-1}(\mathbb{Q})$, but not of type $FP_n(\mathbb{Q})$.*

Here $FP_n(\mathbb{Q})$ is a homological finiteness condition. It is strictly weaker than the homotopical finiteness condition F_n and thus Proposition 4 does not enable us to answer Question 3.

Finally, let me also mention that in forthcoming work of myself and Pierre Py [11] we prove the existence of subgroups of hyperbolic groups of type F_{n-1} and not F_n for all $n \geq 2$, thus solving Brady's question for all n . These groups will arise as subgroups of cocompact lattices in the holomorphic isometry group $PU(n, 1)$ of the complex hyperbolic ball. To prove our result we will use a novel approach relying on methods from complex geometry rather than Bestvina–Brady Morse theory, making it essentially different from the one described above.

REFERENCES

- [1] N. Brady, *Branched coverings of cubical complexes and subgroups of hyperbolic groups*, J. London Math. Soc. (2) **60**, No. 2 (1999), 461–480.
- [2] S. P. Fisher, *Improved algebraic fibrations*, preprint arXiv:2112.00397 (2021).
- [3] K. Fujiwara and J. Manning, *CAT(0) and CAT(−1) fillings of hyperbolic manifolds*, J. Differential Geom. **85**, No. 2 (2010), 229–269.
- [4] M. Gromov, *Hyperbolic groups*, Essays in group theory, Math. Sci. Res. Inst. Publ. **8**, Springer, New York (1987), 75–263.
- [5] G. Italiano, B. Martelli and M. Migliorini, *Hyperbolic manifolds that fiber algebraically up to dimension 8*, preprint arXiv:2010.10200 (2020).
- [6] G. Italiano, B. Martelli and M. Migliorini, *Hyperbolic 5-manifolds that fiber over S^1* , preprint arXiv:2105.14795 (2021).
- [7] D. Kielak, *Residually finite rationally solvable groups and virtual fibering*, J. Amer. Math. Soc. **33**, No. 2 (2020), 451–486.
- [8] D. Kielak, *Fibering over the circle via group homology*, in Manifolds and groups, Abstracts from the workshop held February 9–15, 2020. Organized by Clara Löh, Oscar Randal-Williams and Thomas Schick. Oberwolfach Rep. **17**, No. 1 (2020).
- [9] R. Kropholler, *Hyperbolic Groups with Finitely Presented Subgroups not of Type F_3* Geom. Dedicata **213** (2021), 589–619, with an Appendix by G. Gardam.
- [10] C. Llosa Isenrich, B. Martelli, P. Py, *Hyperbolic groups containing subgroups of type \mathcal{F}_3 not \mathcal{F}_4* , preprint arXiv:2112.06531 (2021).
- [11] C. Llosa Isenrich, P. Py, *Subgroups of hyperbolic groups, finiteness properties and complex hyperbolic lattices*, in preparation.
- [12] Y. Lodha, *A hyperbolic group with a finitely presented subgroup that is not of type FP_3* , Geometric and cohomological group theory, London Math. Soc. Lecture Note Ser. **444**, Cambridge Univ. Press, Cambridge, (2018), 67–81.

- [13] W. Lück, *Dimension theory of arbitrary modules over finite von Neumann algebras and L^2 -Betti numbers. II. Applications to Grothendieck groups, L^2 -Euler characteristics and Burnside groups*, J. Reine Angew. Math. **496** (1998), 213–236.
- [14] E. Rips, *Subgroups of small cancellation groups*, Bull. London Math. Soc. **14**, No. 1 (1982), 45–47.

Homological filling functions and the word problem

ROBERT KROPHOLLER

(joint work with Noel Brady and Ignat Soroko)

The word problem in finitely presented groups is deeply related to the Dehn function. Namely, we have the following theorem:

Theorem 1. *Let G be a finitely presented. Then G has solvable word problem if and only if the Dehn function of G is bounded by a recursive function.*

The Dehn function of a finitely presented is independent, up to equivalence, of finite presentation. For the larger class of finitely presented groups there are many analogues. We will focus on a class between finitely generated groups and finitely presented groups.

Definition 2. *A group G is of type FH_2 if G acts geometrically on a connected simplicial complex X with $H_1(X) = 0$.*

The condition of type FH_2 is equivalent to being of type FP_2 and is implied for finite presentability. Since the Dehn function requires a finite presentation to be well-defined we must modify the definition. We do this as follows.

Definition 3. *Let X be a simplicial complex with $H_1(X) = 0$. For each 1-cycle $\gamma \in X^{(1)}$ there exists a 2-chain $c = \sum_i a_i \sigma_i$ where $a_i \in \mathbb{Z}$ and σ_i are 2-cells in X , such that $\gamma = \partial c$.*

The homological area of γ is

$$\text{HArea}_X(\gamma) = \min \left\{ \sum_i |a_i| \mid \gamma = \partial c, c = \sum_i a_i \sigma_i \right\}.$$

We define the homological filling function of X as

$$\text{FA}_X(n) = \sup \left\{ \text{HArea}_X(\gamma) \mid \gamma \text{ is a 1-cycle in } X^{(1)} \text{ with } |\gamma| \leq n \right\},$$

where $|\gamma|$ is the size of γ , given by the ℓ^1 -norm on the cellular chain group $C_1(X)$.

Let H be a group of type FH_2 define the homological filling function of H to be FA_X for some space X with a geometric H -action and $H_1(X) = 0$.

The homological filling function of a group is well-defined up to the equivalence on functions $f, g: \mathbb{N} \rightarrow \mathbb{N}$ given by $f \preceq g$ if and only if there is a C such that $f(n) \leq Cg(Cn + C) + Cn + C$.

Various other basic facts about FA_H can be found in [3]. For instance, this function is a quasi-isometry invariant for groups of type FH_2 .

The definition given here is designed to mirror that of the Dehn function for finitely presented groups. A natural question is whether this function detects

solvability of the word problem for groups of type FH_2 . We show that this is not the case:

Theorem 4. [3] *There exists groups H of type FH_2 with $FA_H \simeq n^4$ with unsolvable word problem.*

To prove Theorem 5, we build on the pushing techniques of [1], which were used to study the filling functions of Bestvina-Brady groups, and apply them to Leary’s groups $G_L(S)$ [5]. The group $G_L(S)$ depends on a flag complex L and $S \subset \mathbb{Z}$. By [5], we know that when $H_1(L) = 0$ the group $G_L(S)$ is of type FH_2 . We prove the following theorem.

Theorem 5. [3] *Let L be a connected flag complex with $H_1(L) = 0$. Let FA_L be the homological filling function for $\pi_1(L)$ and $H = G_L(S)$. Then*

- For any $S \subset \mathbb{Z}$, we have $FA_H(n) \leq n^2 FA_L(n^2)$.
- For any $S \subset \mathbb{Z}$, we have $FA_H(n) \leq n^4 FA_L(n)$.
- If $S \neq \mathbb{Z}$, then $FA_H \succeq FA_L$.

If $\pi_1(L) \neq 0$, then the groups $G_L(S)$ form an uncountable family of groups up to isomorphism [5]. This is also true for quasi-isometry [4]. There are only countably many algorithms, thus there are only countably many finitely generated groups with solvable word problem. Thus for each L with $\pi_1(L) \neq 0$ we obtain groups of the form $G_L(S)$ with unsolvable word problem. In certain cases, we can see that for $S \neq \mathbb{Z}$ the upper bound and lower bound from Theorem 5 agree. For instance, by starting with a 2-complex with fundamental group

$$\langle a, b, c \mid b^{-1}ab = a^2, b = \prod_{i=1}^8 [b^i, c^i], c = \prod_{i=9}^{11} [b^i, c^i] \rangle$$

one obtains uncountably many groups with homological filling function equivalent to 2^n .

We end with three questions regarding homological filling functions. Since there are only countably many finitely presented groups there can be only countably many equivalence classes of Dehn functions. For groups of type FH_2 this is no longer the case. Thus it is natural to ask the following.

Question 6. *Are there uncountably many equivalence classes of homological filling functions for groups?*

One could attempt to prove this by using the groups $G_L(S)$ for varying S . In our work, the only dependence on S seen is in the cases $S = \mathbb{Z}$ and $S \neq \mathbb{Z}$. If one were to gain a dependence on the set S one could hope to answer the above question. We pose the following as a first step towards this.

Question 7. *Given $S, T \subsetneq \mathbb{Z}$. Are the homological filling functions for $G_L(S)$ and $G_L(T)$ equivalent?*

Finally, we show in [3] that $G_L(S)$ has solvable word problem if and only if $\pi_1(L)$ has solvable word problem and S is recursive. Thus all our examples are

infinitely presented. This leads us to the following question for finitely presented groups.

Question 8. *Let H be a finitely presented group. Suppose that FA_H is bounded by a recursive function. Does H have solvable word problem?*

It is worth mentioning that the homological filling function and the Dehn function can have very different behaviour for finitely presented groups. Indeed, in [2] groups H with $\text{FA}_H(n) \preceq n^5$ and $2^n \preceq \delta_H(n)$.

REFERENCES

- [1] A. Abrams, N. Brady, P. Dani, M. Duchin and R. Young. Pushing fillings in right-angled Artin groups. *J. Lond. Math. Soc.*, 87:663–688, 2013.
- [2] A. Abrams, N. Brady, P. Dani and R. Young. Homological and homotopical Dehn functions are different. *Proc. Natl. Acad. Sci.*, 48:19206–19212, 2013.
- [3] N. Brady, R. Kropholler and I. Soroko. Homological Filling functions [arXiv:2012.00730](https://arxiv.org/abs/2012.00730).
- [4] R. Kropholler, I. Leary and I. Soroko. Uncountably many quasi-isometry classes of groups of type FP . *Amer. J. Math.* 142, 6:1931-1944, 2020.
- [5] I. Leary. Uncountably many groups of type FP . *Proc. Lond. Math. Soc.*, 117: 246-276, 2015.

Charmenability

URI BADER

(joint work with Boutonnet-Houdayer-Peterson and Vigdorovich)

The prominent example of the action of $\text{GL}_n(\mathbb{Z})$ on the torus \mathbb{T}^n has the following two features:

- (Stiffness) In every invariant closed convex subset of probability measures there exists an invariant one.
- (Finiteness) An ergodic invariant measure is either the Haar measure, or supported on a finite orbit.

The above dynamical system could be interpreted as follows. Considering the group $\Gamma = \mathbb{Z}^n$, we have that $\text{GL}_n(\mathbb{Z}) \simeq \text{Aut}(\Gamma)$ and the space probability measures on \mathbb{T}^n is identified with the space of positive definite function on Γ .

With Itamar Vigdorovich we study the question of Stiffness and Finiteness for the action of $\text{Aut}(\Gamma)$ on the space of positive definite function on Γ , where Γ is an arbitrary nilpotent group.

With Boutonnet-Houdayer-Peterson we consider the case where Γ is a higher rank lattice. Then, virtually, $\Gamma \simeq \text{Aut}(\Gamma)$ and we prove the following:

- (Stiffness) In every invariant closed convex subset of positive definite functions there exists an invariant one.
- (Finiteness) An extremal invariant positive definite function is either von Neumann amenable or supported on the amenable radical.

A group which satisfies the above two properties is called *charmenable*. Applying the above two results together, we get that an arithmetic group is charmenable iff its semisimple part is not of rank 1. More precisely, we have the following.

Theorem [B-Vigdorovich]: Let G be a \mathbb{Q} -algebraic group. Then either all arithmetic subgroups of G are charmenable or none of them are. Denoting by R the solvable radical of G , the first case occurs if and only if the real rank of G/R is not equal to 1 and G/R has at most one \mathbb{R} -isotropic \mathbb{Q} -simple factor.

REFERENCES

- [1] Bader, Boutonnet, Houdayer and Peterson, *Charmenability of arithmetic groups of product type*, to appear 2022.
- [2] Bader and Vigdorovich *Charmenability and Stiffness of Arithmetic Groups*, in preparation.

Balls in essential manifolds and actions on Cantor spaces

ROMAN SAUER

(joint work with Sabine Braun)

We report on the following result in [1] which is the non-sharp macroscopic cousin of the well-known conjecture that rationally essential manifolds do not admit a metric of positive scalar curvature (the statement for $R = 1$ readily implies the one for all $R > 0$ by scaling the metric). Let $V_{(\widetilde{M}, \widetilde{g})}(R)$ denote the maximal volume of an R -ball on the universal cover of a Riemannian manifold (M, g) .

Theorem. *There is a dimensional constant $\epsilon(d) > 0$ with the following property. For every rationally essential Riemannian manifold (M, g) of dimension d and every $R > 0$ we have*

$$V_{(\widetilde{M}, \widetilde{g})}(R) > \epsilon(d) \cdot R^d.$$

If $\epsilon(d)$ could be chosen to be the volume of a Euclidean d -ball, then the above conjecture would follow. A closed oriented manifold is *rationally essential* if its classifying map sends the fundamental class to a non-zero class in rational homology. Guth proves the above theorem in [2] for closed aspherical manifolds. The extension to rationally essential manifolds needs a number of new tools from topological dynamics of actions on Cantor spaces and equivariant topology.

We also report on ongoing work with D. Raede which aims at making the constant $\epsilon(d)$ explicit. Unlike the work with S. Braun which is based on Guth's methods this project combines the ideas from topological dynamics with recent work of Papasoglu [3].

REFERENCES

- [1] S. Braun and R. Sauer, *Volume and macroscopic scalar curvature*, *Geom. Funct. Anal.* **31** (2022), 1321–1376.
- [2] L. Guth, *Volumes of balls in large Riemannian manifolds*, *Ann. of Math. (2)* **173** (2011), 51–76.
- [3] P. Papasoglu, *Uryson width and volume*, *Geom. Funct. Anal.* **30** (2020), 574–587.

Property (T) for $\text{Aut}(F_n)$

PIOTR W. NOWAK

(joint work with M. Kaluba and D. Kielak)

Property (T) was introduced by Kazhdan in 1966 and has become a fundamental rigidity property for groups. Only a few classes infinite groups are known to satisfy property (T), including most notably lattices in higher rank Lie groups, automorphism groups of thick buildings and certain random hyperbolic groups. We refer to [1] as the most comprehensive overview of property (T).

Recently a new characterization of property (T) due to Ozawa [8] described property (T) for a finitely generated group G in terms of an algebraic spectral gap-type condition, expressed in the form of the equation

$$(1) \quad \Delta^2 - \lambda\Delta = \sum_{i=1}^k \xi_i^* \xi_i,$$

in the real group ring $\mathbb{R}G$, where $\Delta = 1 - |S|^{-1} \sum_{s \in S} s$ is the Laplacian associated to a finite, symmetric generating set S , $\lambda > 0$ and $\xi_i \in \mathbb{R}G$. This characterization allowed for a new strategy to be used to prove property (T) for infinite groups: solving (1) with the aid of positive definite programming. This method was first implemented by Netzer and Thom [7] to give a new proof of property (T) for the group $\text{SL}_3(\mathbb{Z})$ and to improve significantly the estimate of its Kazhdan constant. Similar result were later obtained for $\text{SL}_n(\mathbb{Z})$ by Fujiwara and Kabaya for $n = 3, 4$ [2] and Kaluba and Nowak for $n = 3, 4, 5$ [3].

The first new group for which property (T) was proved using this new approach was $\text{Aut}(F_5)$, the automorphism group of the free group on 5 generators [4]. The infinite case was settled subsequently by Kaluba, Kielak and Nowak [5] in the form of the following

Theorem. *The group $\text{Aut}(F_n)$ has property (T) for $n \geq 6$.*

As numerical methods can only be applied to a single group at a time, a key ingredient of the proof of the above theorem is a technique of decomposing equation (1) in the group $\text{SAut}(F_n)$, a subgroup of $\text{Aut}(F_n)$ of index 2, into smaller pieces. More precisely, whenever $m \geq n$ the Laplacian element $\Delta_m \in \mathbb{R}\text{SAut}(F_m)$ can be written in terms of copies of the Laplacian $\Delta_n \in \text{SAut}(F_n)$, that are stitched together by the action of the alternating group Alt_m .

A similar idea is then applied to the square of the Laplacian $\Delta^2 \in \text{SAut}(F_m)$, which is first decomposed into a sum of three other elements of the group ring, the square part Sq_m , the opposite part Op_m and the adjacent part Adj_m . For each of these elements there is a separate decomposition formula, which allows to express such an element in $\mathbb{R}\text{SAut}(F_m)$ in terms of sums of translates of corresponding elements $\mathbb{R}\text{SAut}(F_n)$. These facts allow to express the equation $\Delta_m^2 - \lambda\Delta_m$, for a certain positive λ , in terms of the operators Sq_n , Op_n and Adj_n . Then a single computation using semidefinite programming in the ring $\mathbb{R}\text{SAut}(F_5)$ is used to finish the proof.

The same argument applies in the case of the family $\mathrm{SL}_n(\mathbb{Z})$, where an algebraic spectral gap certified in the group ring of $\mathrm{SL}_5(\mathbb{Z})$ additionally yields new estimates on Kazhdan constants of $\mathrm{SL}_n(\mathbb{Z})$ for $n \geq 6$, which asymptotically are $1/2$ of the well-known upper bound of $\sqrt{\frac{2}{n}}$.

Another consequence is a new answer to a question of Lubotzky about the dependence on the generating of the property of being expanders. Indeed, as $\mathrm{Aut}(F_n)$, $n \geq 3$, are residually alternating, there exists a sequence of alternating groups Alt_{k_i} such that as quotients of $\mathrm{Aut}(F_n)$ and with the inherited generating set their Cayley graphs form a sequence of expanders, while they are known not to be expanders with respect to their usual generating sets.

Another application concerns an algorithm used to generate random elements in finite groups. Lubotzky and Pak [6] studied the Product Replacement Algorithm and have observed that it can be described in terms of a certain natural action of $\mathrm{Aut}(F_n)$ and the associated random walk, whose fast convergence would be implied by a spectral gap. Our results showing property (T) for $\mathrm{Aut}(F_n)$ for $n \geq 5$, combined with those of Lubotzky and Pak, thus provide the explanation of the surprisingly fast convergence of the Product Replacement Algorithm.

REFERENCES

- [1] B. Bekka, P. de la Harpe, A. Valette, *Kazhdan's property (T)*, Cambridge University Press 2008.
- [2] K. Fujiwara, Y. Kabaya, *Computing Kazhdan constants by semidefinite programming*, Experimental Mathematics, 28:3, 301–312.
- [3] M. Kaluba, P.W. Nowak, *Certifying numerical estimates of spectral gaps*, Groups Complexity Cryptology, Volume 10 (2018), Issue 1, Pages 33–41.
- [4] M. Kaluba, P.W. Nowak, N. Ozawa, *$\mathrm{Aut}(\mathbb{F}_5)$ has property (T)*, Mathematische Annalen, Volume 375 (2019), Issue 3–4, p 1169–1191.
- [5] M. Kaluba, P.W. Nowak, D. Kielak, *On property (T) for $\mathrm{Aut}(F_n)$ and $\mathrm{SL}_n(\mathbb{Z})$* , Annals of Mathematics, Vol. 193 (2021), Issue 2, p. 539–562
- [6] A. Lubotzky, I. Pak, *The product replacement algorithm and Kazhdan's property (T)*, Journal of the American Mathematical Society 14 (2001), no. 2, 347–363.
- [7] T. Netzer, A. Thom, *Kazhdan's property (T) via semidefinite optimization*, Experimental Mathematics, 24:3, 371–374.
- [8] N. Ozawa, *Noncommutative real algebraic geometry of Kazhdan's property (T)*, Journal of the Institute of Mathematics of Jussieu, Vol. 15, Issue 01 (2016), p. 85–90.

Shadows of galleries in buildings

PETRA SCHWER

(joint work with Elizabeth Milićević, Yusra Naqvi and Anne Thomas)

One of the main tools when studying affine buildings are retractions. They are closely linked to both the combinatorics of folded galleries as well as the orbits of various prominent subgroups in the reductive groups defining the buildings. This link gives rise to a combinatorial model which allows to understand orbits on and sub-varieties of affine Grassmannians and affine flag varieties.

In this talk I presented a new formalization of chimney retractions using filters on half-apartments and explained how these retractions connect to folded galleries and shadows. The main source for this talk is [6] as well as [4, 2].

1. CLASSICAL RETRACTIONS

It is well known that any affine building admits two types of retractions. More formally suppose X is an affine building with atlas \mathcal{A} , then

- (1) for every apartment $A \in \mathcal{A}$ and every alcove $c \in A$ there exists a retraction $r_{A,c} : X \rightarrow A$ such that the restriction of $r_{A,c}$ onto any apartment $A' \supset c$ is an isomorphism fixing $A \cap A'$ pointwise. And
- (2) for every apartment $A \in \mathcal{A}$ and every Weyl chamber $C \in A$ there exists a retraction $\rho_{A,\partial C} : X \rightarrow A$ such that the restriction of $\rho_{A,\partial C}$ onto any apartment A' with $\partial A' \supset \partial C$ is an isomorphism fixing $A \cap A'$ pointwise.

The first of these retractions is defined with respect to a maximal simplex in X while the second is defined with respect to a maximal simplex in the visual boundary of X , which is itself a spherical building.

In case the building X is of algebraic origin we find a (split, connected, reductive) group G defined over a non-archimedean local field F with discrete valuation such that X is the Bruhat-Tits building of G over F . Denote by \mathcal{O} the ring of integers of F and let $K = G(\mathcal{O})$. The group G admits several nice decompositions:

$$G = UTK = IWI = KTK,$$

where T is a (split) maximal torus, U the unipotent radical of the Borel $B = TU$ and I the Iwahori subgroup of $G(F)$. The group $W = N(T)/Z(T)$ is the associated affine Weyl group.

There is a close connection between the retractions and these decompositions which comes from the fact that K is the stabilizer in $G(F)$ of a vertex in the apartment A on which T acts as translations. This vertex is sometimes referred to as the origin of X . The Iwahori group I is the stabilizer of the fundamental alcove c_0 in A which contains the origin. The Iwahori may also be seen as the lift into $G(F)$ of the (spherical) Borel in the residue building at the origin. In addition the group U stabilizes the direction of the fundamental Weyl chamber C_0 and may hence be seen as the stabilizer of a maximal simplex ∂C_0 in the sphere ∂A at infinity of the affine apartment A . Using this one obtains for a point $p \in A$ that

$$r_{A,c_0}^{-1}(p) = I.p \quad \text{and} \quad \rho_{A,\partial C_0}^{-1}(p) = U.p.$$

This allows to go back and forth between geometric objects, such as preimages under retractions, and algebraic objects, such as orbits of points. One application is the following direct analog of Kostant's convexity which I proved in [4]. This theorem answers the question of how the T -part of an element $g \in G$ changes when one multiplies the element $g = utk$ on the left by some $k' \in K$. The algebraic statement is a direct consequence of the geometric statement using the translation via retractions explained above.

Theorem 1 ([4] Kostant convexity for buildings). *Let X be a thick affine building, fix an apartment A , a fundamental alcove c and a fundamental Weyl chamber C in A . Then*

$$\rho_{A,\partial C}(r_{A,c}^{-1}(\bar{W}.\lambda)) = \text{conv}^*(\bar{W}.\lambda)$$

for any vertex λ in A .

Moreover, if X is the BT-building associated with a group G as explained above, then for any vertex $\lambda = tK$ one has

$$Ut'K \cap KtK \neq \emptyset \iff t \in \text{conv}^*(\bar{W}.\lambda).$$

In the theorem above $\text{conv}^*(\bar{W}.\lambda)$ denotes the set of those vertices in the metric convex hull of the spherical Weyl group orbit $\bar{W}.\lambda$ which have the same type as λ . The proof relies on the fact that one can track end-vertices of images of galleries under retractions.

2. CHIMNEY RETRACTIONS

A natural way to compactify an affine building X is to take the union of X with its Tits or visual boundary at infinity. One of the retractions discussed above was determined by a maximal simplex in this boundary. In other words, we were retracting from a chamber in the spherical building at infinity.

A different type of compactification of X , see for example work of Guivarch-Rémy [3] or Caprace-Lecureux [1], is obtained by taking the union of X with the affine buildings obtained from parallel classes of so called chimneys. In the algebraic case a different way of saying what is done is to take the union of a Bruhat-Tits building X of a group G over F together with the affine Bruhat-Tits buildings of the Levi factors of G .

These smaller buildings arise exactly like the panels trees appearing in the literature and are attached at infinity of parallel classes of panels or smaller dimensional faces of Weyl chambers. The maximal simplices in these boundary buildings correspond to chimneys which are certain filters of half-spaces in apartments similar to the cubes in the roller boundary of a cubical complex. Roughly speaking one can also think of chimneys as translates of certain strips in the building X which bounded by parallel walls of distance one in some of the root directions. A precise definition of a chimney is given in [6].

An piece of an affine building X of type \tilde{A}_2 together with some of the wall trees are shown in Figure 1 to illustrate the compactification using affine buildings at infinity. In this case there are three types of chimneys: one corresponds to alcoves (i.e. triangles) in the building X . The second type corresponds to alcoves in the wall trees. Such a chimney can be pictured by a strip between two walls. An example is shaded grey in the same figure. The third class corresponds to vertices at infinity which represent a Weyl chamber direction in X . Again an example is shaded in (a slightly darker) grey. One has

- (3) For every chimney ξ there is a retraction $r_\xi : X \rightarrow A$ such that the restriction of r_ξ to any apartment A' containing ξ is an isomorphism onto A fixing $A' \cap A$ pointwise.

This definition looks a lot like the previous definitions of retractions with the advantage that only one definition is needed to get all the $n + 1$ retractions of an n -dimensional affine building.

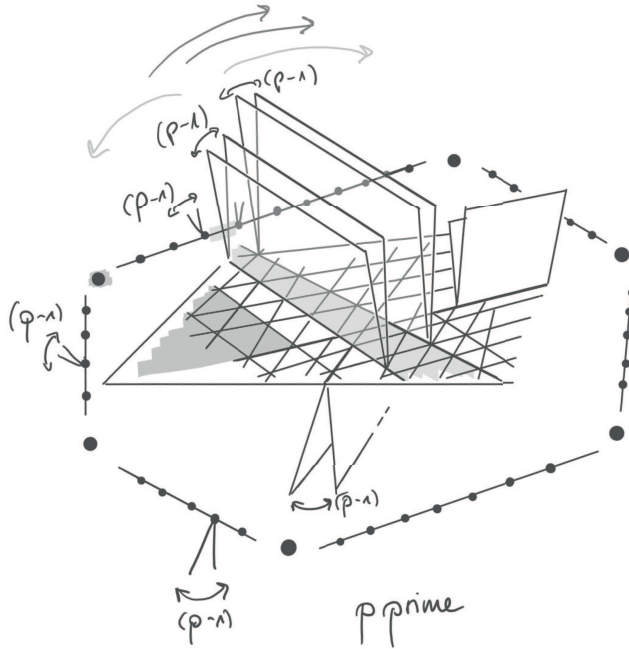

FIGURE 1. Part of a two-dimensional affine building with chimneys (shaded in grey) and its boundary buildings of dimension one and zero.

As in the classical case, retractions are closely linked with double coset intersections. And again one can understand these retractions and double coset intersections using galleries.

Definition 2. Let σ be a simplex in an apartment A and let ξ be a chimney in the same apartment. The shadow $Sh_\xi(\sigma)$ of σ with respect to ξ is the collection of end-simplices of galleries starting in the fundamental alcove c_0 which are obtained by ξ -positively folding a minimal gallery from c_0 to σ .

In the classical case $Sh_{\partial C_0}(\lambda) = conv^*(\bar{W}.\lambda)$. Similar to the convexity theorem one can show the following result with the caveat that we don't yet have a closed description of the shadow in the formula.

Theorem 3 ([6]). For all alcoves x, y, z in A there is a bijection between the points in

$$IxI \cap (I_P)^y zI$$

and ξ_y -positively folded galleries from c_0 to z of type x counted with multiplicities. Moreover $Sh_{\xi_y}(x) = r_{\xi_y}(r_{c_0}^{-1}(x))$.

Recursive descriptions of certain shadows are obtained in [2] and [6]. One application of the study of these double coset intersections was given by Milićević, Thomas and myself in [5, 7] where we compute non-emptiness and dimensions of affine Deligne-Lusztig using folded galleries and chimney retractions.

3. SUMMARY

Let me summarize what we have learned and give you three take-home messages:

- Buildings are great - they have retractions!¹
- In understanding shadows we understand retractions.
- Shadows are used to study affine flag varieties and affine Grassmannians.

The connection between double coset intersection, retractions, folded galleries and shadows is explained for a general audience in [8].

REFERENCES

- [1] Pierre-Emmanuel Caprace, Jean Lécureux, *Combinatorial and group-theoretic compactifications of buildings*, Ann. Inst. Fourier (Grenoble), No. 2, Vol. 61, pp. 619–672, (2011).
- [2] Marius Graeber, Petra Schwer, *Shadows in Coxeter groups*, Ann. Comb., Vol. 24, pp. 119–147, (2020).
- [3] Yves Guivarc’h, Bertrand Rémy, *Group-theoretic compactification of Bruhat-Tits buildings*, journal = Ann. Sci. École Norm. Sup. (4), No. 6, Vol. 39, pp. 871–920, (2006).
- [4] Petra Hitzelberger, *Kostant convexity for affine buildings*, Forum Mathematikum, Volume 22, Number 5, (2010).
- [5] Elizabeth Milićević, Petra Schwer, Anne Thomas, *Dimensions of affine Deligne-Lusztig varieties: a new approach via labeled folded alcove walks and root operators*, Mem. Am. Math. Soc., Vol. 1260, (2019).
- [6] Elizabeth Milićević, Petra Schwer, Anne Thomas, *A gallery model for affine flag varieties via chimney retractions*, to appear in Transformation groups, arXiv:1912.09911 [math.RT], (2019).
- [7] Elizabeth Milićević, Petra Schwer, Anne Thomas, *Affine Deligne-Lusztig varieties and folded galleries governed by chimneys*, arXiv:2006.16288 [math.AG], (2020).
- [8] Petra Schwer, *Shadows in the Wild - Folded Galleries and Their Applications*, Jahresbericht der DMV, Vol. 124, pp. 3–41, (2022).

On the homology torsion growth for $SL_d(\mathbb{Z})$, Artin groups and mapping class groups

DAMIEN GABORIAU

(joint work with Miklos Abert, Nicolas Bergeron and Mikolaj Fraczyk)

The growth of the sequence of Betti numbers is quite well understood when considering a suitable sequence of finite sheeted covers of a manifold or of finite index subgroups of a countable group.

¹Misha Kapovich once told me this and what can I say - I agree!

We are interested in other homological invariants, like the growth of the mod p Betti numbers and the growth of the torsion of the homology. We produce new vanishing results on the growth of torsion homologies in higher degrees for $\mathrm{SL}_d(\mathbf{Z})$, Artin groups and mapping class groups. As a central tool, we introduce a quantitative homotopical method that constructs "smaller" classifying spaces for finite index subgroups, while controlling at the same time the complexity of the homotopy equivalence. Our method easily applies to free abelian groups and then extends recursively to a wide class of residually finite groups.

We obtain the following typical kind of results:

Theorem 1 ([ABFG21]). *Let Γ be a countable residually finite group. Let (Γ_n) be a residual chain or a Farber sequence of finite index subgroups. Let \mathbb{K} be **any** field. For every degree $j \leq \alpha$, we have:*

$$\frac{\dim_{\mathbb{K}} H_j(\Gamma_n, \mathbb{K})}{[\Gamma : \Gamma_n]} \longrightarrow 0 \quad \text{and} \quad \frac{\log |H_j(\Gamma_n, \mathbb{Z})_{\mathrm{tors}}|}{[\Gamma : \Gamma_n]} \longrightarrow 0 \quad \text{as } n \rightarrow \infty,$$

where the value α depending on the group Γ may be taken as follows:

- $\Gamma = \mathrm{SL}_d(\mathbf{Z}) \rightsquigarrow \alpha = d - 2$; more generally Γ an arithmetic lattices in a semi-simple affine algebraic groups \mathbf{G} and $\alpha = \mathrm{rank}_{\mathbf{Q}}(\mathbf{G}) - 1$;
- $\Gamma = \mathrm{MCG}(S_g) \rightsquigarrow \alpha = 2g - 2$; more generally if the surface has genus g and b boundary components $\Gamma = \mathrm{MCG}(S_{g,b}) \rightsquigarrow \alpha = 2g - 3 + b$ when $g \geq 1$ and $b \geq 1$, while $\alpha = b - 4$ if $g = 0$ and $b \geq 4$;
- $\Gamma =$ residually finite Artin group for which the $K(\pi, 1)$ conjecture is satisfied $\rightsquigarrow \alpha$ such that the nerve is $(\alpha - 1)$ -connected;
- $\Gamma = \mathrm{Out}(W_n)$ where $W_n = \mathbf{Z}/2\mathbf{Z} * \mathbf{Z}/2\mathbf{Z} * \cdots * \mathbf{Z}/2\mathbf{Z}$ (n times) $\rightsquigarrow \alpha = \lfloor \frac{n}{2} \rfloor - 1$ (This last example comes from joint work with Yassine Guerch and Camille Horbez [GGH22]).

Observe that both the existence of a limit and the independence relatively to the sequence of subgroups in the above theorem are not at all obvious a priori.

I present the basic objects and some of the ideas.

REFERENCES

- [ABFG21] M. Abert, N. Bergeron, M. Fraczyk, and D. Gaboriau. On homology torsion growth. *arXiv:2106.13051*, 2021.
- [GGH22] D. Gaboriau, Y. Guerch, and C. Horbez. On the complex of partial bases and the homology growth of $\mathrm{Out}(W_n)$. Work in progress.

Locally testable codes

SHAHAR MOZES

(joint work with Irit Dinur, Shai Evra, Ron Livne, Alexander Lubotzky)

An error correcting code is a subset $C \subseteq \mathbb{F}_2^n$. We will think of elements of C as words of length n "bits" (0's and 1's). The rate of a code is $\rho(C) = \log_2(|C|)/n$, its distance $\delta(C)$ is the minimal Hamming distance between any two codewords,

normalized by dividing by n . A code is called Locally Testable if there is a "tester" who given a word $w \in \mathbb{F}_2^n$ reads q randomly chosen bits from w and decides whether to accept or reject the word so that if $w \in C$ accepts with probability 1 and if $w \notin C$ rejects with probability at least $\kappa \cdot \text{dist}(w, C)$. Where $\kappa > 0$ and $q \in \mathbb{N}$ are some fixed constants. (We say that such a code is κ -Locally Testable with q -queries.)

Our main result is proving the existence of an infinite family of locally testable codes with rate and distance bounded below and fixed q and κ .

Theorem. *For every $0 < r < 1$ there exist $\delta, \kappa > 0$, $q \in \mathbb{N}$ and a polynomial time construction of an infinite family of error correcting codes $\{C_n\}$ with rates at least r , distances at least δ and for every n C_n is a κ -locally testable code with q -queries.*

The codes we construct are linear codes. Let us mention that Panteleev and Kalachev [2] have announced construction of codes with similar properties at the same time and independently.

A key ingredient in the construction of these codes is the use of certain high dimensional expanders which are finite square complexes, the LR-Cayley square complex $C(G, A, B)$, associated with a group with two symmetric generating sets A, B and which have good expansion properties. The square complex $C(G, A, B)$ is may be viewed as taking the union of a left Cayley graph of G with respect to A and a right Cayley graph of G with respect to B (on the same set of vertices G) and gluing a square for each $g \in G$, $a \in A$, $b \in B$ at the edges $\{g, ag\}, \{ag, agb\}, \{agb, gb\}, \{gb, g\}$. Note that there are two types of edges in the complex: edges corresponding to elements of A ("A-edges") and edges corresponding to elements of B ("B-edges"). To define the code one chooses two fixed linear codes $C_A \subset \mathbb{F}_2^A$ and $C_B \subset \mathbb{F}_2^B$. The link of an A-edge can be identified with B and the link of a B-edge can be identified with A . The code C is defined to be the linear subspace of all maps $f : C(G, A, B)^{(2)} \rightarrow \mathbb{F}_2$ from the squares of $C(G, A, B)$ to \mathbb{F}_2 so that for each A-edge the restriction of f to squares containing it (its link) is in C_B and similarly for B-edges the restriction to the corresponding link is in C_A . This construction can be viewed as a generalization of the celebrated Sipser Spielman [3] expander codes. For an appropriate choices of the "local" codes C_A and C_B and a family of groups G with sets of generators A and B having good expansion properties one obtains locally testable codes as in the theorem. Given a word, i.e., a labelling of the faces of the squares of the square complex by elements of \mathbb{F}_2 the tester chooses a random vertex and checks whether the labelling of its link belongs to $C_A \otimes C_B$.

REFERENCES

- [1] Irit Dinur, Shai Evra, Ron Livne, Alexander Lubotzky and Shahar Mozes. *Locally Testable Codes with constant rate, distance, and locality*. arXiv preprint arXiv:2111.04808 , 2021
- [2] Pavel Panteleev and Gleb Kalachev. *Asymptotically good quantum and locally testable classical LDPC codes*. arXiv preprint arXiv:2111.03654, 2021.
- [3] Michael Sipser and Daniel Spielman. *Expander codes*. IEEE Transactions on Information Theory, 42.6: 1710-1722, 1996.

Euler characteristics of complexes of graphs

KAREN VOGTMANN

(joint work with Michael Borinsky)

Outer space CV_n is a contractible space of graphs originally introduced to study the group $Out(F_n)$ of outer automorphisms of a finitely-generated free group F_n [1]. Outer space decomposes naturally as a union of open simplices, but is not a simplicial complex because some of the faces of these open simplices are missing. If one includes the missing faces, one obtains a contractible simplicial complex CV_n^* called the *simplicial closure* of Outer space.

The simplicial closure CV_n^* gives rise to several chain complexes which appear in other areas of mathematics, such as Kontsevich's graph complexes and tropical algebraic geometry. For example the quotient \overline{CV}_n^* of CV_n^* by the action of $Out(F_n)$ is what the tropical geometers call the *moduli space of tropical curves* of genus n . As another example, Kontsevich's *even commutative graph complex* $\mathcal{GC}_2^{(n)}$ is easily identified with the relative chain complex $C_*(\overline{CV}_n^*, \overline{CV}_n^\infty)$, where CV_n^∞ is the (invariant) subcomplex consisting of simplices that are not contained in CV_n and the bar again indicates the quotient by the action of $Out(F_n)$. For the study of $Out(F_n)$ a subcomplex K_n of the barycentric subdivision $(CV_n^*)'$ called the *spine of Outer space* is important; this is the subcomplex spanned by all vertices of $(CV_n^*)'$ that are not in $(CV_n^\infty)'$. The spine K_n is quasi-isometric to $Out(F_n)$ and the chain complex $C_*(\overline{K}_n)$ computes the rational homology of $Out(F_n)$. In addition, by a theorem of Kontsevich the homology of this chain complex can be identified with the homology of his *odd Lie graph complex* $\mathcal{LG}^{(n)}$ [5].

The purpose of this talk was to explain how techniques borrowed from quantum field theory can be used to study both the virtual and naive Euler characteristics of these chain complexes. Here by the naive Euler characteristic we mean the alternating sum of the Betti numbers, i.e. the usual Euler characteristic of the quotient space. The virtual Euler characteristic takes the group action into account; it counts the alternating sum of the number of orbits of simplices of dimension i divided by the order of their stabilizers. The virtual Euler characteristic is considerably easier to compute and has other virtues; for example it behaves well with respect to short exact sequences of groups, and for arithmetic groups and surface mapping class groups it can be computed in terms of zeta functions.

The talk focused on a specific example, namely the virtual Euler characteristic of $C_*(\overline{CV}_n^*, \overline{CV}_n^\infty)$. I explained how to find a combinatorial generating function $\mathbb{F}(\hbar)$ for this number, then how to view this generating function as the path integral of a 0-dimensional scalar quantum field theory with a very simple potential function $V(\hbar)$. Specifically, $V(x) = e^x - 1 - x$ and $\mathbb{F}(\hbar)$ is the path integral for

$$\frac{1}{\sqrt{2\pi\hbar}} \int_{\mathbb{R}} e^{\frac{-x^2}{2\hbar}} e^{\frac{-1}{\hbar}(e^x - 1 - x)} dx.$$

It happens that this expression is actually integrable (unlike the integral associated to most potentials), and we can deduce (up to some easily understood factors)

that $\mathbb{F}(\hbar)$ is the asymptotic expansion of the Gamma function in the scale $\{\hbar^k\}$ as $\hbar \rightarrow 0$. Sterling’s classical formula expresses the asymptotic expansion of the Gamma function in terms of Bernoulli numbers, and we conclude that the virtual Euler characteristic is 0 if n is even and $\frac{B_{n+1}}{n(n+1)}$ if n is odd.

The rest of the talk sketched how to use the cubical structure of the spine of Outer space to obtain a generating function for the virtual Euler characteristic $\chi(\text{Out}(F_n))$ in a similar way. With more work, this method can be souped up to compute the naive Euler characteristic $e(\text{Out}(F_n))$. Earlier, in [3], we had found a different generating function for $\chi(\text{Out}(F_n))$, which we were able to use to determine the sign and asymptotic growth rate of $\chi(\text{Out}(F_n))$. The form of the new generating functions makes it possible to extract from our previous work the fact that the ratio of $e(\text{Out}(F_n))$ to $\chi(\text{Out}(F_n))$ tends to $e^{-\frac{1}{4}} \approx .78$ as $n \rightarrow \infty$.

REFERENCES

[1] M. Culler and K. Vogtmann, Moduli of graphs and automorphisms of free groups, *Invent. Math.* **84.1** (1986), 91–119.
 [2] M. Borinsky, *Graphs in perturbation theory: Algebraic structure and asymptotics*. Springer, 2018.
 [3] M. Borinsky and K. Vogtmann, *The Euler characteristic of $\text{Out}(F_n)$* , *Comm. Math. Helv.* **95.4** (2020), 703–748.
 [4] M. Borinsky and K. Vogtmann, *Computing Euler characteristics using quantum field theory*, arXiv:2202.08739.
 [5] M. Kontsevich, *Formal (non)-commutative symplectic geometry*. The Gel’fand Mathematical Seminars, 1990–1992: 173–187, Birkhäuser Boston, 1993.

Origami expanders

TIM DE LAAT

(joint work with Goulmara Arzhantseva, Dawid Kielak, Damian Sawicki)

Spectral gap is an important rigidity property for measure-preserving group actions with various applications, one of which is the construction of expanders. Let G be a group generated by a finite symmetric generating set S . A probability measure-preserving action $G \curvearrowright (X, \mu)$ has spectral gap if there exists a constant $\kappa > 0$ such that for every $f \in L^2(X, \mu)$ with $\int_X f d\mu = 0$, we have $\sum_{s \in S} \|s.f - f\|_2 \geq \kappa \|f\|_2$, where $(s.f)(x) = f(s^{-1}x)$.

Let $\mathbb{T}^2 = \mathbb{R}^2/\mathbb{Z}^2$ be the 2-torus, which we identify with $[0, 1)^2 \subseteq \mathbb{R}^2$ equipped with Lebesgue measure. For an integer $k \geq 1$, consider the elementary matrices

$$(1) \quad a_k = \begin{pmatrix} 1 & k \\ 0 & 1 \end{pmatrix} \quad \text{and} \quad b_k = \begin{pmatrix} 1 & 0 \\ k & 1 \end{pmatrix}.$$

It goes back to [9, 4] that for every $k \in \mathbb{Z}_{\geq 1}$, the natural action of the group $\langle a_k, b_k \rangle$ generated by a_k and b_k on \mathbb{T}^2 has spectral gap. It is standard that for $k \geq 2$, the group $\langle a_k, b_k \rangle$ is a free group.

Another class of fundamental examples of actions with spectral gap comes from rotations of the sphere \mathbb{S}^2 ; see e.g. [3, 5, 2].

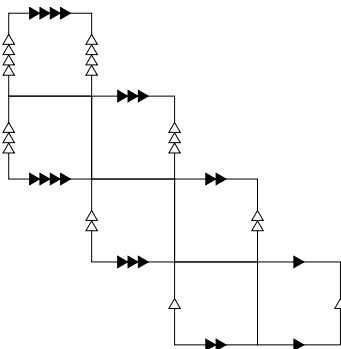

FIGURE 1. The staircase of genus 4.

The aim of this talk is to explain a new class of actions with spectral gap, namely on surfaces of arbitrary genus $g \geq 1$, and to mention the construction of a new type of expanders coming from these actions. Concretely, the surfaces we consider are origami surfaces. These are obtained by gluing together finitely many copies of the unit square in such a way that the resulting surface is a branched covering of \mathbb{T}^2 . Special cases of origami surfaces were first studied in [10, 11]; the name origami was introduced in [6]. The following result is [1, Theorem A].

Theorem 1. *Let Σ be an arbitrary origami surface. Then the free group \mathbb{F}_2 admits a measure-preserving action by Lipschitz homeomorphisms on Σ with spectral gap.*

This theorem gives the first examples of measure-preserving actions with spectral gap on surfaces of higher genus g , i.e., genus $g > 1$.

Let us now recall the notion of origami surface more precisely. Let (m, σ, τ) be a triple, where m is a positive integer, and σ and τ are elements of $\text{Sym}(\{1, \dots, m\})$ such that the subgroup they generate acts transitively on $\{1, \dots, m\}$. An origami surface (or square-tiled translation surface) associated with (m, σ, τ) is a topological space Σ constructed as follows: Let $\{P_1, \dots, P_m\}$ be m copies of the square $[0, 1]^2$ together with homeomorphisms $\rho_i: P_i \rightarrow [0, 1]^2$. The space Σ is obtained by gluing, for every $i \in \{1, \dots, m\}$, the left side of P_i (coming from the left side of $[0, 1]^2$ under the homeomorphism ρ_i etc.) to the right side of $P_{\sigma(i)}$, in such a way that precomposing this gluing with ρ_i^{-1} and postcomposing with $\rho_{\sigma(i)}$ yields a map sending the left side of $[0, 1]^2$ to its right side by translation. We proceed analogously in the vertical direction, using τ .

The maps ρ_i combine to a single map $\rho: \Sigma \rightarrow \mathbb{T}^2$, which is a branched covering of the torus \mathbb{T}^2 branching over at most one point. Topologically, Σ is a connected, closed, orientable surface. It also carries a measure μ of total measure m , inherited on each of the squares P_i from the Lebesgue measure on $[0, 1]^2$.

An example of an origami surface of genus 4 is given in Figure 1. For obvious reasons, this origami surface is called the staircase Z_4 . Analogously, we can consider the staircase Z_g of arbitrary genus g .

Let Σ be an origami surface associated with the triple (m, σ, τ) , consider the matrices a_k, b_k from (1), and suppose that $k \geq 2$ is any multiple of the orders of σ and τ . Let us now define an action of $\mathbb{F}_2 = \langle a_k, b_k \rangle$ on Σ .

Definition 2. *Let Σ be an origami surface and P_i a square of Σ . The horizontal arrangement map associated with P_i is the unique map $h_i: \mathbb{R} \times [0, 1] \rightarrow \Sigma$ satisfying the following conditions:*

- *For every $j \in \mathbb{Z}$, postcomposing the restriction of h_i to $[j, j + 1] \times [0, 1]$ with ρ coincides with the composition of the translation by $(-j, 0)$ with the natural quotient map $[0, 1]^2 \rightarrow \mathbb{T}^2$.*
- *The square $[0, 1]^2$ is mapped to P_i .*

The vertical arrangement map associated with P_i is the map $v_i: [0, 1] \times \mathbb{R} \rightarrow \Sigma$ defined analogously.

Note that the matrices a_k and b_k preserve the subsets $\mathbb{R} \times [0, 1]$ and $[0, 1] \times \mathbb{R}$ of \mathbb{R}^2 , respectively. Consider a square P_i of Σ , and let $h_i: \mathbb{R} \times [0, 1] \rightarrow \Sigma$ be the corresponding horizontal arrangement map. The action of a_k on P_i is obtained by first lifting P_i to $[0, 1]^2$ under h_i^{-1} , then applying the matrix a_k , and then projecting back to Σ using h_i . We define the action of b_k analogously, using the vertical arrangement map. This procedure yields a well-defined action of $\langle a_k, b_k \rangle$ on Σ . It can be verified that this action satisfies the conclusion of Theorem 1. We refer to [1] for a detailed proof.

Let us briefly discuss the construction of a new type of expanders, coming from the above group actions. Expanders are sequences of finite, highly connected, sparse graphs with an increasing number of vertices; see e.g. [7] for the definition. One way to construct expanders is from actions with spectral gap. This idea already (implicitly) underlied several of the earliest explicit constructions of expanders, e.g. the original Margulis expander [8]. For a systematic study of this method, we refer to [12], in which the expanders constructed from a group action with spectral gap are quasi-isometric to appropriate sequences of level sets of the warped cone over the action, which is a metric space encoding the dynamics of the group action.

The second part of [1] studies the expanders associated with the warped cones of the actions of Theorem 1. We call these origami expanders. They turn out to be coarsely distinct from previous constructions of expanders, and we refer to [1] for many results on the coarse geometry of these expanders. As an example of such a result, let us mention the following theorem, which is [1, Theorem D].

Theorem 3. *Let $g \geq 2$, and let Z_g be the staircase of genus g (see Figure 1) equipped with the action of \mathbb{F}_2 as constructed above. Let $(\Gamma_n)_n$ be an expander that is quasi-isometric to the warped cone over $\mathbb{F}_2 \curvearrowright Z_g$. Then:*

- *The expander $(\Gamma_n)_n$ is not coarsely equivalent to any box space.*
- *The expander $(\Gamma_n)_n$ is not coarsely equivalent to any warped cone \mathcal{O}_HY , where H is an infinite group, Y is a manifold, and the action $H \curvearrowright Y$ is free.*

REFERENCES

- [1] G. Arzhantseva, D. Kielak, T. de Laat and D. Sawicki, *Origami expanders*, preprint (2021), arXiv:2112.11864.
- [2] J. Bourgain and A. Gamburd, *On the spectral gap for finitely-generated subgroups of $SU(2)$* , *Invent. Math.* **171** (2008), no. 1, 83–121.
- [3] V.G. Drinfel'd, *Finitely-additive measures on S^2 and S^3 , invariant with respect to rotations* (Russian), *Funktsional. Anal. i Prilozhen.* **18** (1984), no. 3, 77.
- [4] O. Gabber and Z. Galil, *Explicit constructions of linear-sized superconcentrators*, *J. Comput. System Sci.* **22** (1981), no. 3, 407–420.
- [5] A. Gamburd, D. Jakobson and P. Sarnak, *Spectra of elements in the group ring of $SU(2)$* , *J. Eur. Math. Soc. (JEMS)* **1** (1999), no. 1, 51–85.
- [6] P. Lochak, *On arithmetic curves in the moduli spaces of curves*, *J. Inst. Math. Jussieu* **4** (2005), no. 3, 443–508.
- [7] A. Lubotzky, *Discrete Groups, Expanding Graphs and Invariant Measures*, Birkhäuser Verlag, Basel, 2010.
- [8] G.A. Margulis, *Explicit constructions of expanders* (Russian), *Problemy Peredači Informacii* **9** (1973), no. 4, 71–80.
- [9] J. Rosenblatt, *Uniqueness of invariant means for measure-preserving transformations*, *Trans. Amer. Math. Soc.* **265** (1981), no. 2, 623–636.
- [10] W.P. Thurston, *On the geometry and dynamics of diffeomorphisms of surfaces*, *Bull. Amer. Math. Soc. (N.S.)* **19** (1988), no. 2, 417–431.
- [11] W.A. Veech, *Teichmüller curves in moduli space, Eisenstein series and an application to triangular billiards*, *Invent. Math.* **97** (1989), no. 3, 553–583.
- [12] F. Vigolo, *Measure expanding actions, expanders and warped cones*, *Trans. Amer. Math. Soc.* **371** (2019), no. 3, 1951–1979.

The Kaplansky conjectures

GILES GARDAM

There is a series of four long-standing conjectures on group rings that are attributed to Kaplansky, namely the *unit*, *zero divisor*, *idempotent* and *direct finiteness conjectures*.

Conjecture. *Let G be a group and K be a field. If G is torsion free, then the group ring $K[G]$ has*

- *no non-trivial units,*
- *no non-zero zero divisors, and*
- *no idempotents other than 0 and 1.*

For arbitrary G , the group ring $K[G]$ is

- *directly finite, that is, if $ab = 1$ for $a, b \in K[G]$ then $ba = 1$.*

A group ring element of the form kg for $k \in K \setminus \{0\}$ and $g \in G$ is called a trivial unit. The unit and zero divisor conjectures were first formulated in Higman's thesis [2, p. 77] but were popularized by Kaplansky [4]. The idempotent conjecture has its origins in a 1949 conversation of Kadison and Kaplansky; the conjecture that the reduced group C^* -algebra of a torsion-free group has no non-trivial idempotents is known as the Kadison–Kaplansky conjecture. The direct finiteness conjecture

was raised by Kaplansky following his proof that it holds if K has characteristic zero [3, pp. 122–123]

The author recently gave an explicit counterexample [1] to the unit conjecture using the virtually abelian group sometimes referred to as the Hantzsche–Wendt group, which Promislow showed to be a candidate by virtue of not having the unique product property [8].

Theorem 1. *Let P be the torsion-free group defined by the presentation*

$$\langle a, b \mid b^{-1}a^2b = a^{-2}, a^{-1}b^2a = b^{-2} \rangle$$

and set $x = a^2, y = b^2, z = (ab)^2$. Set

$$\begin{aligned} p &= (1+x)(1+y)(1+z^{-1}) & q &= x^{-1}y^{-1} + x + y^{-1}z + z \\ r &= 1 + x + y^{-1}z + xyz & s &= 1 + (x + x^{-1} + y + y^{-1})z^{-1}. \end{aligned}$$

Then $p + qa + rb + sab$ is a non-trivial unit in the group ring $\mathbb{F}_2[P]$.

While the unit conjecture remains open in characteristic zero, Murray subsequently gave counterexamples with the same group P in every positive characteristic [6].

The four Kaplansky conjectures form a chain of implications. It is a trivial fact that a ring with no non-zero zero divisors has no non-trivial idempotents and a ring with no non-trivial idempotents is directly finite. It is also known that if the group ring of a torsion-free group has no non-trivial units then it has no non-zero zero divisors [7, Lemma 13.1.2]. The zero divisor conjecture is known for many groups, such as residually torsion-free elementary amenable groups [5], whereas the unit conjecture is false for the very mild Hantzsche–Wendt group. This suggests there is a large gulf between the two conjectures. However, the zero divisor conjecture is in fact a statement about units: if it is false, then there is a counterexample in positive characteristic, and if G is torsion-free and K has positive characteristic then $K[G]$ satisfies the conjecture if and only if its group of units has no non-trivial torsion.

The main obstacle to constructing a counterexample to the zero divisor conjecture is the lack of explicit candidates (torsion-free and without the unique product property) given by small presentations. The set of such candidates is at least now known to be non-empty.

Theorem 2. *The torsion-free group Δ defined by the presentation*

$$\langle a, b, c, d, e, f, g \mid acb, add, afg, bbf, cdg, cef, eeg \rangle$$

does not have the unique product property.

This \tilde{A}_2 -lattice has no linear representations over \mathbb{C} with infinite image and has property (T). As far as the author is aware, this rules out all existing techniques to prove the zero divisor conjecture.

Question. *Does Δ satisfy the zero divisor conjecture?*

REFERENCES

- [1] G. Gardam, *A counterexample to the unit conjecture for group rings*, *Annals of Mathematics* **194** (2021), 967–979.
- [2] G. Higman, *Units in group rings*, D.Phil. thesis, University of Oxford, 1940.
- [3] I. Kaplansky, *Fields and rings*, University of Chicago Press (1969).
- [4] I. Kaplansky, “*Problems in the theory of rings*” revisited, *American Mathematical Monthly* **77** (1970), 445–454.
- [5] P. H. Kropholler, P. A. Linnell, and J. A. Moody, *Applications of a new K -theoretic theorem to soluble group rings*, *Proceedings of the American Mathematical Society* **104** (1988), 675–684.
- [6] A. G. Murray, *More Counterexamples to the Unit Conjecture for Group Rings*, arXiv preprint [arXiv:2106.02147](https://arxiv.org/abs/2106.02147) (2021).
- [7] D. S. Passman, *The algebraic structure of group rings*, Robert E. Krieger Publishing Co. (1985).
- [8] S. D. Promislow, *A simple example of a torsion-free, nonunique product group*, *Bulletin of the London Mathematical Society* **20** (1988), 302–304.

An invitation to coarse groups

FEDERICO VIGOLO

(joint work with Arielle Leitner)

A *coarse space* is a space that is equipped with a notion of “uniform boundedness”. Prototypical examples of coarse spaces are metric spaces: a family of subsets of (X, d) is uniformly bounded if there is an upper bound on their diameters. A natural non-metric example is given by topological groups: a family of subsets of (G, τ) is uniformly bounded if they are all contained in left translates of some compact subset of G . A general coarse space is a set equipped with a coarse structure $\mathbf{X} = (X, \mathcal{E})$ as defined by Roe in [7]. For the purpose of this talk, we may assume that \mathcal{E} is induced by a metric or a topology as explained above. *Coarse geometry* is the study of those geometric features of a coarse space that are preserved under uniformly bounded perturbations.

A map between coarse spaces is *controlled* if it preserves uniform boundedness. According to the coarse philosophy, we should not be able to differentiate between close functions. We thus say that a *coarse map* $\mathbf{f}: \mathbf{X} \rightarrow \mathbf{Y}$ is an equivalence class of controlled functions, where we identify close functions. Two coarse spaces are *coarsely equivalent* if there are coarse maps $\mathbf{f}: \mathbf{X} \rightarrow \mathbf{Y}$ and $\mathbf{g}: \mathbf{Y} \rightarrow \mathbf{X}$ such that $\mathbf{g} \circ \mathbf{f} = \text{id}_{\mathbf{X}}$ and $\mathbf{f} \circ \mathbf{g} = \text{id}_{\mathbf{Y}}$. For example, it is simple to verify that two geodesic metric spaces are coarsely equivalent if and only if they are quasi-isometric.

Coarse spaces and coarse maps are objects and morphisms of the *category of coarse spaces*. A *coarse group* is a group object in this category. Concretely, it is a coarse space $\mathbf{G} = (G, \mathcal{E})$ together with a multiplication $*$ and an inversion $(\cdot)^{-1}$ that satisfy the group axioms up to uniformly bounded error. The study of coarse groups and their coarse homomorphisms has connections with a number of different topics going from geometric group theory to number theory and functional analysis. The basic elements of this theory fit together rather nicely: there are notions of coarse homomorphisms, isomorphisms, subgroups and quotients. The

coarse analogues of the Isomorphism Theorems hold true [3]. This talk is a brief introduction and survey of the subject, with emphasis on examples.

The first examples of coarse groups are obtained from groups. If d is a left-invariant metric on a group G , the coarse space $\mathbf{G} = (G, \mathcal{E}_d)$ need not be a coarse group because the multiplication function need not be controlled. Up to coarse equivalence, one can actually verify that \mathbf{G} is a coarse group if and only if d a *bi-invariant* metric on G . Besides abelian groups, many natural groups come equipped with bi-invariant metrics, *e.g.* the Hamming distance on the symmetric group S_n and the metric induced by operator norm $d(T, S) = \|T - S\|$ on the group $U(\mathcal{H})$ of unitary operators on a Hilbert (or Banach) space.

If G is a group and \mathcal{E} is a coarse structure so that $\mathbf{G} = (G, \mathcal{E})$ is a coarse group, we say that \mathbf{G} is a coarsification of G . Every finitely generated group Γ admits a canonical coarsification. Namely, if S is a finite generating set and \overline{S} is the union of all its conjugates, then the word metric $d_{\overline{S}}$ associated with \overline{S} is bi-invariant and hence $(G, d_{\overline{S}})$ is a coarse group. This coarsification is canonical because different generating sets give rise to bi-Lipschitz equivalent metrics. One may also verify that this is the finest “connected” coarsification of G . In turn, this raises the following natural question:

Problem 1. *Given a finitely generated group G , is $d_{\overline{S}}$ unbounded?*

It is not hard to show that $d_{\overline{S}}$ is unbounded if G admits unbounded quasimorphisms $\phi: G \rightarrow \mathbb{R}$. In particular, this is the case if G is hyperbolic or fibers over \mathbb{Z} . In the opposite direction, $d_{\overline{S}}$ is bounded on $Sl(n, \mathbb{Z})$ and the infinite dihedral group D_∞ . More in general, it is a known that every affine Coxeter group and many higher rank arithmetic lattices are bounded [4, 6, 8]. The following is a known open question:

Question 2 ([1]). *Let G be a lattice in a higher rank simple Lie group with finite centre. Is $d_{\overline{S}}$ bounded?*

Exotic examples of coarse groups are obtained by considering *coarse subgroups* (these can be defined as images of coarse homomorphisms [3]). For instance, if $\mathbf{G} = (G, \mathcal{E})$ is a coarsified group and $X \subset G$ is an approximate subgroup in the sense of in the sense of Breuillard–Green–Tao then one may modify the group operations to make $(X, \mathcal{E}|_X)$ into a coarse group. This coarse group \mathbf{X} is truly coarse, in the sense that these modified operations will no longer satisfy the group axioms.

One example of interest is as follows. Let $(F_2, d_{\overline{S}})$ be the free group on two generators equipped with its canonical coarsification, and let $\phi: F_2 \rightarrow \mathbb{R}$ be the homomorphism defined by sending one generator to 1 and the other to an irrational number. One may verify that the preimage $K := \phi^{-1}(-1, 1)$ is an approximate subgroup of F_2 , hence $\mathbf{K} = (K, d_{\overline{S}}|_K)$ is a coarse subgroup (it is the “coarse kernel” of ϕ [3]). We conjecture that this coarse group is very far from being a coarsified group. Namely, we pose the following:

Conjecture 3. *There does not exist a group G with a coarsification $\mathbf{G} = (G, \mathcal{E})$ such that \mathbf{G} and \mathbf{K} are isomorphic coarse groups.*

In the converse direction, using an appropriate weakening of the notion of coarse structure we can prove the following:

Theorem 4 ([3]). *For every coarse group \mathbf{G} there exists a group G' with a “fragmentary coarsification” so that \mathbf{G} is isomorphic to a coarse subgroup of (G', \mathcal{E}) .*

One interesting object of study is the group $\text{Aut}_{\text{Crs}}(\mathbf{G})$ of coarse automorphisms of a given coarse group \mathbf{G} . For concreteness, we propose the following:

Problem 5. *For $n \geq 2$, study the group $\text{Aut}_{\text{Crs}}(F_n, d_{\overline{S}})$ and its subgroups.*

To provide some motivation, the following result follows easily from the work of Hartnick–Schweitzer:

Theorem 6 ([2, 3]). *The group $\text{Aut}_{\text{Crs}}(F_n, d_{\overline{S}})$ has torsion of arbitrary order, it contains an infinite simple group and there is a natural embedding $\text{Out}(F_n) \hookrightarrow \text{Aut}_{\text{Crs}}(F_n, d_{\overline{S}})$.*

With regard to the embedding $\text{Out}(F_n) \hookrightarrow \text{Aut}_{\text{Crs}}(F_n, d_{\overline{S}})$, it is intriguing to compare it with its abelian analogue. In fact, it is simple to observe that $\text{Aut}_{\text{Crs}}(\mathbb{Z}^n, d_{\overline{S}}) \cong \text{Aut}_{\text{Crs}}(\mathbb{R}^n, d_{\|\cdot\|}) \cong \text{Gl}(n, \mathbb{R})$, while $\text{Out}(\mathbb{Z}^n) \cong \text{Gl}(n, \mathbb{Z})$ and the analogous homomorphism $\text{Out}(\mathbb{Z}^n) \rightarrow \text{Aut}_{\text{Crs}}(\mathbb{Z}^n, d_{\overline{S}})$ is nothing but the inclusion $\text{Gl}(n, \mathbb{Z}) \subset \text{Gl}(n, \mathbb{R})$. One can obtain a great deal of information on $\text{Gl}(n, \mathbb{Z})$ by observing that the index two subgroup $\text{Sl}(n, \mathbb{Z}) < \text{Gl}(n, \mathbb{Z})$ is a lattice in the simple Lie group $\text{Sl}(n, \mathbb{R}) < \text{Gl}(n, \mathbb{R})$. In analogy, it is natural to wonder whether $\text{Aut}_{\text{Crs}}(F_n, d_{\overline{S}})$ or some subgroup of it can be used to study $\text{Out}(F_n)$.

To conclude, the following problem is a first step towards a study of the structure theory of coarse groups.

Problem 7. *Classify the coarsifications of \mathbb{Z} .*

If S is an infinite generating set of \mathbb{Z} , the induced word metric d_S defines a coarsification of \mathbb{Z} . For a given set S , it is natural to ask whether d_S is bounded. For instance, if S is the set of all primes, boundedness of d_S is a non-effective version of the Goldbach conjecture. More generally, it is an interesting number theoretic problem to understand whether two sets S, S' give rise to the same coarse structure [5].

Another class of coarsifications of \mathbb{Z} consists of those of the form (\mathbb{Z}, τ) where τ is some group topology on \mathbb{Z} . Considering profinite topologies, one can show that there are at least a continuum of different coarsifications of \mathbb{Z} [3]. It would be interesting to know if there are $2^{2^{\aleph_0}}$ distinct coarsifications.

REFERENCES

- [1] S. Gal and J. Kedra, *On bi-invariant word metrics*, Journal of Topology and Analysis **3** (2011), no. 2, 161-175.
- [2] T. Hartnick and P. Schweitzer, *On quasiisomorphism groups of free groups and their transitivity properties*, Journal of Algebra **450** (2016), 242-281.
- [3] A. Leitner and F. Vigolo, *An invitation to coarse groups*, arXiv:2203.08591 (2022).

- [4] J. Lewis, J. McCammond, K. Petersen and P. Schwer, *Computing reflection length in an affine Coxeter group*, Transactions of the AMS **371** (2019), no. 6, 4097-4127.
- [5] M. Nathanson, *Geometric group theory and arithmetic diameter*, Publ. Math. Debrecen **79** (2011), no. 3-4, 563-572.
- [6] L. Polterovich, Y. Shalom and Z. Shem-Tov, *Norm rigidity for arithmetic and profinite groups*, arXiv:2105.04125 (2021).
- [7] J. Roe, *Lectures on coarse geometry*, Univ. Lec. Series, AMS, 2003.
- [8] A. Trost, *Strong boundedness of simply connected split Chevalley groups defined over rings*, arXiv:2004.05039 (2020).

Condensed Mathematics

PETER KROPHOLLER

Let G be a topological group satisfying the T_1 separation axiom (so the trivial subgroup is closed). The Clausen–Scholze condensed mathematics promises an abelian category of *condensed* G -modules that is closed under arbitrary limits and colimits and which has enough projectives. This makes it at once possible to perform classical methods of homological algebra, to define $\text{Ext}_G^*(A, B)$ by using a projective resolution of the condensed G -module A , and even to define Farrell–Tate cohomology $\widehat{\text{Ext}}_G^*(A, B)$ in which case projective resolutions of both A and B are required. The theory uses a philosophy akin to the methods of algebraic geometry as laid down in Grothendieck’s famous Tohoku paper [3]. In fact, in the wake of Grothendieck’s work many foundational principles of condensed mathematics can be seen in the writings of Gleason [2], of Dyckhoff [1], and of other authors: the combination of Grothendieck’s framework using the earlier insights of Steenrod and others could have led to the same goal in the nineteen sixties or seventies but instead developments took a different direction. Condensed Mathematics had to wait until 2018 to be discovered when Clausen joined Scholze’s research group at the University of Bonn. The pair very rapidly developed a complete theory to a level considerably higher than we can comprehend in this short lecture.

1. ILLUSTRATION

Consider the identity map $\mathbb{R}^\delta \rightarrow \mathbb{R}$ from the reals made discrete to the reals with their normal topology. This is a continuous bijection, an isomorphism of the abstract additive groups, but not an isomorphism of topological abelian groups: the inverse is discontinuous. Now consider the one point compactification $\mathbb{N} \cup \{\infty\}$ of the natural numbers and replace \mathbb{R}^δ and \mathbb{R} by continuous \mathbb{R}^δ - and \mathbb{R} -valued functions with domain $\mathbb{N} \cup \{\infty\}$. The induced map $[\mathbb{N} \cup \{\infty\}, \mathbb{R}^\delta] \rightarrow [\mathbb{N} \cup \{\infty\}, \mathbb{R}]$ is injective but not surjective. The domain consists of eventually constant sequences, the codomain consists of all convergent sequences. What was once a surjection now has a huge cokernel. We are using maps from the *test space* $\mathbb{N} \cup \{\infty\}$ to distinguish the discrete group from the topological and in an algebraic manner by means of distinct vector spaces of sequences. The received wisdom is that we should consider other test spaces, not just $\mathbb{N} \cup \{\infty\}$: Clausen and Scholze invite us to consider all compact Hausdorff spaces.

2. APPLICATIONS

Here is a taster of the kinds of results that can be proved: one of Clausen–Scholze, and a second more recently formulated of my own. The first is central to Scholze’s Liquid Tensor Experiment [5].

Theorem (Clausen–Scholze). *Let $0 < p' < p \leq 1$ be real numbers, let S be a profinite set, and let V be a p -Banach space. Let $\mathcal{M}_{p'}(S)$ be the space of p' -measures on S . Then $\text{Ext}_{\text{Cond}(\mathbf{Ab})}^i(\mathcal{M}_{p'}(S), V) = 0$ for all $i \geq 1$.*

In this Theorem the Ext groups are computed over the category $\text{Cond}(\mathbf{Ab})$ of condensed abelian groups: we’ll come to the definition below. The second result is rather more open-ended: a Metatheorem because its exact meaning depends on an interpretation of the notion of hierarchical decomposition that has yet to be fully researched. In a hierarchically decomposable group, there are certain *preferred* subgroups one of which is the group itself. To each such subgroup H there is an associated ordinal $\alpha(H)$ known as the *height* so that if $H \subset K$ are preferred subgroups then $\alpha(H) \leq \alpha(K)$.

Metatheorem. *Let G be a hierarchically decomposable T_1 topological group. Suppose that A is a condensed G -module of type FP_∞ and B is a condensed G -module that is projective on restriction to every height zero subgroup of G . Then $\widehat{\text{Ext}}_{\text{Cond}(\mathbf{Mod}\text{-}G)}^i(A, B) = 0$ for all $i \in \mathbb{Z}$.*

Both Theorem and Metatheorem are cohomological vanishing theorems.

3. DEFINITIONS, EXAMPLES, PROOFS

Let \mathbf{KHaus} denote the category of compact Hausdorff spaces and let \mathbf{Set} denote the category of sets. A *condensed set* is a contravariant functor $S : \mathbf{KHaus}^{\text{op}} \rightarrow \mathbf{Set}$ such that two axioms hold.

Sh1: $S(T \sqcup T') = S(T) \times S(T')$ — S takes disjoint unions to products.

Sh2: A statement about equalisers: see [4] for the details.

3.1. Examples. For an example of a condensed set, take any Hausdorff space X and consider the functor $\underline{X} := [_, X]$ that send a compact Hausdorff space to the set of continuous X -valued functions. That is, *functions*, not homotopy classes of functions. This construction immediately produces condensed sets: that is to say Axioms Sh1 and Sh2 hold automatically.

3.2. Simplifications. The forgetful functor $\mathbf{KHaus} \rightarrow \mathbf{Set}$ has a left adjoint β which sends a set X to its Stone–Ćech compactification βX . This has a universal property like a free group: given any function f from X to a compact Hausdorff space Z there is a unique continuous map $\beta X \rightarrow Z$ extending f . In particular, Stone–Ćech compactifications satisfy the *naive projective property*: any map from βX to the codomain Z of an epimorphism $Y \twoheadrightarrow Z$ of compact Hausdorff spaces factors through the domain Y . The compact Hausdorff spaces that have this projective property are precisely the retracts of the Stone–Ćech compactifications and they are the objects of a full subcategory \mathbf{Proj} of \mathbf{KHaus} . Gleason

proved that a compact Hausdorff space is projective if and only if the closure of every open subset is open (a property that goes by the arcane title ‘*extremally disconnected*’). What matters here is that all projective compact Hausdorff spaces are totally disconnected and therefore profinite. So we have three categories $\mathbf{Proj} \subset \mathbf{Profinite} \subset \mathbf{KHaus}$ and three wonderful things hold true: first, we can use any one of these three categories to define a condensed set because using the axioms Sh1 and Sh2, any compliant functor with domain \mathbf{Proj} or $\mathbf{Profinite}$ extends uniquely by right Kan extension to the domain \mathbf{KHaus} . Secondly, when the domain is \mathbf{Proj} the second Axiom Sh2 is implied by the first Axiom Sh1. So now we have a very simple definition: a *condensed set* is a contravariant functor $\mathbf{Proj}^{\text{op}} \rightarrow \mathbf{Set}$ such that Sh1 holds. Thirdly, if you have a functor that doesn’t satisfy Axiom Sh1 (such a gadget is called a *presheaf*) there is a natural sheafification that does satisfy Axiom Sh1.

A *condensed abelian group* is a contravariant functor $\mathbf{Proj}^{\text{op}} \rightarrow \mathbf{Ab}$ such that Sh1 holds. In fact you can define condensed anythings just so long as the category of anythings has finite products so that Sh1 makes sense. But the category of abelian groups is particularly attractive. Being an abelian category, epimorphisms are epitomised by coequaliser diagrams and the naive projective property that an object P is projective when every morphism to the codomain of an epimorphism should factor through the domain can be expressed more pithily by saying that $\text{hom}(P, _)$ commutes with finite colimits. An object P in an abelian category is called *compact* if $\text{hom}(P, _)$ commutes with filtered colimits. Scholze then points out that if you take any projective compact Hausdorff space S giving rise to a condensed set $\underline{S} : \mathbf{Proj}^{\text{op}} \rightarrow \mathbf{Set}$ then the presheaf of abelian groups that sends $Z \in \mathbf{Proj}$ to the free abelian group on $\underline{S}(Z) = [Z, S]$ sheafifies to a functor that commutes with all limits and colimits. In one sweep the following fact emerges.

The category of condensed abelian groups is closed under all limits and colimits and has enough compact projective objects in the sense that every object is the epimorphic image of a direct sum of compact projectives.

3.3. Proving the Metatheorem. The idea is to prove by induction on the height of H that for all preferred subgroups H of G , $\widehat{\text{Ext}}_{\text{Cond}(\mathbf{Mod}\text{-}G)}^i(A, \text{Ind}_H^G B) = 0$. The theorem will then follow from the special case $H := G$. The base case for the induction comes from the assumption that B is projective as a module for the height zero subgroups using the observation that induction functor takes projective H -modules to projective G -modules. As evidence of the delicacy of matters, note that in the condensed world, induction is not always an exact functor, nor does restriction necessarily preserve projectivity.

REFERENCES

[1] R. Dyckhoff. Projective resolutions of topological spaces. *J. Pure Appl. Algebra*, 7(1):115–119, 1976.
 [2] A. M. Gleason. Projective topological spaces. *Illinois J. Math.*, 2:482–489, 1958.
 [3] A. Grothendieck. Sur quelques points d’algèbre homologique. *Tohoku Math. J. (2)*, 9:119–221, 1957.

- [4] P. Scholze. Lectures on condensed mathematics, 2019.
www.math.uni-bonn.de/people/scholze/Condensed.pdf.
- [5] P. Scholze. Liquid tensor experiment, 2019.
www.ma.imperial.ac.uk/~buzzard/xena/pdfs/liquid_tensor_experiment.pdf.

Groups acting almost freely on 2-dimensional CAT(0) complexes satisfy the Tits Alternative

DAMIAN OSAJDA

(joint work with Piotr Przytycki)

Tits proved that every finitely generated linear group satisfies (what is now called) the *Tits Alternative*, saying that each of its finitely generated subgroups is virtually solvable or contains a nonabelian free group. It is believed that the Tits Alternative is common among ‘nonpositively curved’ groups. However, up to now it has been shown only for few particular classes of groups. The main result of [1] is the following theorem establishing the Tits Alternative for groups acting on 2-dimensional CAT(0) complexes.

Theorem 1. *Let G be a finitely generated group acting on a CAT(0) triangle complex X with a bound on the order of the cell stabilisers. Then G is virtually cyclic, or virtually \mathbb{Z}^2 , or contains a nonabelian free group.*

Corollary 2. *If X has finitely many isometry types of simplices, then Theorem 1 holds also for G infinitely generated.*

As corollaries we obtain the Tits Alternative for subgroups of the tame automorphism group $\text{Tame}(\mathbf{k}^3)$ or of 2-dimensional Artin groups acting with bounds on the orders of the cell stabilisers on appropriate complexes.

As a means of proving the main theorem and as a result of its own interest we present a characterisation of CAT(0) triangle complexes using a link condition. Earlier such characterisations were established for locally compact triangle complexes and for piecewise Euclidean and piecewise hyperbolic triangle complexes.

REFERENCES

- [1] D. Osajda, P. Przytycki, *Tits Alternative for 2-dimensional CAT(0) complexes*, preprint (2021).

Group actions on L_p -spaces : dependance on p

MIKAEL DE LA SALLE

(joint work with Amine Marrakchi)

The study of group actions on Hilbert spaces is central in operator algebras, geometric group theory and representation theory. In many natural situations however, particularly interesting actions on L_p spaces appear for $p \neq 2$. One celebrated example is the construction by Pansu [7] (and later greatly generalized by Yu to all Gromov hyperbolic groups [8]) of proper actions of groups of isometries of hyperbolic spaces on L_p for large p . In these results and many other, the rather clear impression was that it was easier for a group to act on L_p space as p becomes larger. This impression was made more precise by Chatterji, Druţu, and Haglund [2] in a question, that became later known as Druţu’s conjecture.

To be more precise, we need to introduce some notation. Whenever we write L_p , we will mean the space $L_p(X, \mu)$ of real-valued p -integrable functions on a standard measure space (X, μ) . And by action of a topological group G on L_p , we will always mean continuous action of G by affine isometries (the word affine is superfluous if $p \geq 1$, by the Mazur-Ulam theorem). To a topological group, we associate two subsets of the positive real numbers, that can be respectively called the *fixed point spectrum* and *proper action spectrum* of G :

$$F(G) = \{p \in (0, \infty) \mid \text{every action of } G \text{ on } L_p \text{ has bounded orbits}\}$$

and

$$P(G) = \{p \in (0, \infty) \mid G \text{ admits a proper on } L_p\}.$$

Here proper means metrically proper, that is for every $C > 0$, $\{g \in G \mid \|g \cdot x - x\|_p \leq C\}$ is compact for some (equivalently any) $x \in L_p$. So for non-compact groups, these two sets are clearly disjoint, and the proper action spectrum can only be non-empty for locally compact groups.

Druţu’s conjecture is that both sets are intervals, and more precisely that

$$p \in F(G) \implies (0, p] \subset F(G),$$

and

$$p \in P(G) \implies [p, \infty) \subset P(G).$$

For simplicity, we will mostly discuss the fixed point spectrum.

Given an isometric (linear) representation π of G on a Banach space V , the set of affine actions with linear part π , up to a change of origin, is parametrized by the first cohomology group $H^1(G, \pi)$. For the reader unfamiliar with this vocabulary, it is enough to record that the formula $H^1(G, \pi) = 0$ means *every affine action whose linear part is π has a fixed point*.

The classical theorem of Banach and Lamperti says that, for $p \neq 2$, every linear isometry U of $L_p(X, u)$ is of the form

$$Uf(x) = w(x) \frac{dT\mu}{d\mu}(x)^{\frac{1}{p}} f(T(x))$$

for a measurable function $w : X \rightarrow \{-1, 1\}$ and a measurable bijection $T : X \rightarrow X$ preserving the measure class of μ . In other words, this identifies is group of linear isometries of $L_p(X, \mu)$ with

$$\text{Aut}(X, [\mu]) \rtimes L^0(X, \mu; \{-1, 1\}).$$

In particular, since this group does not depend on p , any continuous homomorphism

$$\sigma : G \rightarrow \text{Aut}(X, [\mu]) \rtimes L^0(X, \mu; \{-1, 1\})$$

gives rise to a family $\pi_{p,\sigma} : G \rightarrow O(L_p(X, \mu))$ of linear isometric representations of G on L_p .

The following question is therefore a refined form of Druţu’s conjecture.

Question 1. *Given a continuous homomorphism*

$$\sigma : G \rightarrow \text{Aut}(X, [\mu]) \rtimes L^0(X, \mu; \{-1, 1\}),$$

is the set $\{p \mid H^1(G, \pi_{p,\sigma}) = 0\}$ an interval?

A positive answer is known in several cases: when X is atomic, or (under some additional conditions on G) when μ is a probability measure and σ takes values in the measure-preserving subgroup $\text{Aut}(X, \mu) \rtimes L^0(X, \mu; \{-1, 1\})$ [5, 3, 4, 6].

With Marrakchi, we also observed [6] that if we define the subspace $H^1_{\#}(G, \pi_{p,\sigma})$ of formal coboundaries as $\{b \in H^1(G, \pi_{p,\sigma}) \mid \exists f \in L_0(X, \mu), b(g) = f - \pi_{p,\sigma}(g)f\}$, then

$$\{p \mid H^1_{\#}(G, \pi_{p,\sigma}) = 0\}$$

is an interval. However, this does not answer Question 1 because we do not know whether all cocycles are formal coboundaries. However, this becomes true at the cost of enlarging the space:

Lemma 2. *Let $\sigma : G \rightarrow \text{Aut}(X, [\mu])$, $(A, +)$ be a locally compact abelian group and $c : G \times X \rightarrow A$ a measurable cocycle ($c(gh, x) = c(g, x) + c(h, \sigma(g)^{-1}x)$). Then the formula*

$$(\sigma \rtimes c)_g(x, a) = (gx, a + c(g^{-1})(x))$$

defines a measure-class preserving action of G on $(X \times A, \mu \times \text{Haar})$ such that, if $h(x, a) = a$, $c(g, x) = ((\sigma \rtimes c)_g(h) - h)(x, a)$.

The following is our main theorem.

Theorem 3. [6] *Let G be a topological group. Take $0 < p \leq q < \infty$. Then for every continuous affine isometric action $\alpha : G \curvearrowright L_p$, there exists a continuous affine isometric action $\beta : G \curvearrowright L_q$ such that $\|\alpha_g(0)\|_{L_p}^p = \|\beta_g(0)\|_{L_q}^q$ for all $g \in G$.*

It confirms Druţu’s conjecture, but does not settle Question 1, because the actions on L_p and on L_q are different. Moreover, the action on L_q can be taken so that its linear part comes from a homomorphism $G \rightarrow \text{Aut}(X, \mu)$ for some infinite measure μ .

Theorem 3 is so general and precise that the proof has to be short. And indeed, it amounts to three consecutive applications of Lemma 2, and at the end of

truncation argument. The first application, with $A = \{-1, 1\}$, reduces to actions coming from morphisms

$$G \rightarrow \text{Aut}(X, [\mu]).$$

The second application, with $A = (\mathbf{R}_+^*, \times)$, consists in untwisting the Radon-Nikodym cocycle. This is the classical Maharam extension. The third application, with $A = (\mathbf{R}, +)$, allows to untwist the additive cocycle. The apparently bad news is that, unless A is compact, Lemma 2 destroys all integrability properties of the cocycles. This is fixed by a truncation argument, and this is where the assumption that $q > p$ is used.

REFERENCES

- [1] U. Bader, T. Gelander, and N. Monod. A fixed point theorem for L^1 spaces. *Invent. Math.*, 189(1):143–148, 2012.
- [2] Indira Chatterji, Cornelia Druţu, and Frédéric Haglund. Kazhdan and Haagerup properties from the median viewpoint. *Adv. Math.*, 225(2):882–921, 2010.
- [3] Alan Czuroń. Property $F\ell_q$ implies property $F\ell_p$ for $1 < p < q < \infty$. *Adv. Math.*, 307:715–726, 2017.
- [4] Alan Czuroń and Mehrdad Kalantar. On fixed point property for l_p -representations of kazhdan groups. *arXiv:2007.15168*, 2020.
- [5] Omer Lavy and Baptiste Olivier. Fixed-point spectrum for group actions by affine isometries on L_p -spaces. *Ann. Inst. Fourier (Grenoble)*, 71(1):1–26, 2021.
- [6] Amine Marrakchi and Mikael de la Salle. Isometric actions on L_p -spaces: dependence on the value of p . *arXiv:2001.02490*, 2020.
- [7] Pierre Pansu. Cohomologie L^p des variétés à courbure négative, cas du degré 1. Number Special Issue, pages 95–120 (1990). 1989. Conference on Partial Differential Equations and Geometry (Torino, 1988).
- [8] Guoliang Yu. Hyperbolic groups admit proper affine isometric actions on l^p -spaces. *Geom. Funct. Anal.*, 15(5):1144–1151, 2005.

A strong Tits alternative for $\text{Out}(F_N)$.

VINCENT GUIARDEL

(joint work with Camille Horbez)

A group G satisfies the *Tits alternative* if for any finitely generated subgroup $\Gamma \subset G$, either Γ is virtually solvable or Γ contains a non-abelian free group.

In this talk, we strengthen this notion as follows: we say that a group G satisfies the *strong Tits alternative* if a subgroup $\Gamma \subset G$ is either virtually solvable or SQ-universal.

Recall that Γ is *SQ-universal* if for any countable group A there exists a quotient Q of Γ such that A embeds in Q .

The simplest countable groups which are not SQ-universal are simple groups. Indeed, a SQ-universal groups must have uncountably many non-isomorphic quotients. Similarly, groups such as $SL_3(\mathbb{Z})$ and higher rank lattices are not SQ-universal because of Margulis normal subgroup theorem.

A quite large class of SQ-universal groups is the class of acylindrically hyperbolic groups [2].

Our main Theorem is the following

Theorem 1. *Out(F_N) satisfies the strong Tits alternative. More precisely, any subgroup $\Gamma \subset \text{Out}(F_N)$ which is not virtually abelian has a finite index subgroup which maps onto an acylindrically hyperbolic group.*

Since $\text{Aut}(F_N) \hookrightarrow \text{Out}(F_{N+1})$, it follows that $\text{Aut}(F_N)$ also satisfies the strong Tits alternative.

The analogous result for mapping class groups of surfaces was proved in [2]. A closely related alternative has been proved by Handel-Mosher [5]: given a finitely generated subgroup $\Gamma \subset \text{Out}(F_N)$, either Γ is virtually abelian or its 2nd bounded cohomology group $H_b^2(\Gamma)$ is infinite dimensional.

If $\Gamma \subset \text{Out}(F_N)$ contains a fully irreducible element ϕ , then ϕ acts as a WPD element on the free factor complex of F_N [1]. It follows that Γ is either virtually abelian or SQ-universal and acylindrically hyperbolic.

Using Handel-Mosher's subgroup classification, we can therefore assume that Γ preserves a free factor system \mathcal{G} and that Γ contains an element ϕ which is fully irreducible relative to \mathcal{G} .

When \mathcal{G} is non-sporadic, we thus have an element ϕ that is loxodromic on the relative free factor complex $FF_{\mathcal{G}}$ [4]. The bad news is that contrary to the *absolute* free factor complex, there exist elements $\phi \in \text{Out}(F_N; \mathcal{G})$ which are loxodromic but fail to be WPD on $FF_{\mathcal{G}}$. This was already noticed by Handel and Mosher, and they constructed WWPD elements instead to achieve the bounded-cohomology alternative.

We prove the following stronger result which is a main ingredient of the proof. It is stated as a rigidity result in the Gromov boundary $\partial_{\infty}(FF_{\mathcal{G}})$ of the relative free factor complex.

Theorem 2.

- every loxodromic element $\phi \in \text{Out}(F_N; \mathcal{G})$ is WWPD for its action on $FF_{\mathcal{G}}$
- $\text{Out}(F_N; \mathcal{G})$ acts discretely on the set $(\partial_{\infty} FF_{\mathcal{G}})^{(3)}$ of triples of distinct points at infinity

But we don't know how to deduce SQ-universality from the WWPD condition. Therefore, to get an action with true WPD elements, we cannot work with $FF_{\mathcal{G}}$. The following result allows us to restrict to a virtually Γ -invariant subgroup and get WPD elements.

Theorem 3. *Let $\Gamma \subset \text{Out}(F_N; \mathcal{G})$ be a subgroup acting non-elementarily on $FF_{\mathcal{G}}$.*

Then there exists a subgroup $A < F_N$, invariant under a finite index subgroup $\Gamma^0 \subset \Gamma$ and such that $\Gamma^0|_A$ acts with a WPD element on a suitable relative free factor complex of A .

The proof of this last result builds on the structure of \mathbb{R} -trees having infinite stabilizer, by the first author and Gilbert Levitt, and on the random walk techniques used by the second author in its proof of the Tits alternative for the automorphism group of a free product [6].

REFERENCES

- [1] Mladen Bestvina and Mark Feighn. Hyperbolicity of the complex of free factors. *Adv. Math.*, 256:104–155, 2014.
- [2] F. Dahmani, V. Guirardel, and D. Osin. Hyperbolically embedded subgroups and rotating families in groups acting on hyperbolic spaces. *Mem. Amer. Math. Soc.*, 245(1156):v+152, 2017.
- [3] V. Guirardel, and G. Levitt. Wandering subtrees and stabilizers of trees in the boundary of outer space. In preparation.
- [4] Radhika Gupta. Loxodromic elements for the relative free factor complex. *Geom. Dedicata*, 196:91–121, 2018.
- [5] Michael Handel and Lee Mosher. Hyperbolic actions and 2nd bounded cohomology of subgroups of $\text{Out}(f_n)$. Part I: Infinite lamination subgroups, 2015.
- [6] Camille Horbez. The tits alternative for the automorphism group of a free product, 2014.

Participants

Prof. Dr. Goulmara N. Arzhantseva

Fakultät für Mathematik
Universität Wien
Oskar-Morgenstern-Platz 1
1090 Wien
AUSTRIA

Dr. Uri Bader

Department of Mathematics
The Weizmann Institute of Science
234 Herzl
P.O. Box 26
Rehovot 76 100
ISRAEL

Lara Bessmann

Mathematisches Institut
Universität Münster
Einsteinstraße 62
48149 Münster
GERMANY

Prof. Dr. Emmanuel Breuillard

Department of Pure Mathematics and
Mathematical Statistics
University of Cambridge
Wilberforce Road
Cambridge CB3 0WB
UNITED KINGDOM

Prof. Dr. Martin R. Bridson

Mathematical Institute
Oxford University
Andrew Wiles Building
Woodstock Road
Oxford OX2 6GG
UNITED KINGDOM

Prof. Dr. Marc Burger

Departement Mathematik
ETH-Zürich
ETH Zentrum
Rämistrasse 101
8092 Zürich
SWITZERLAND

**Prof. Dr. Pierre-Emmanuel
Caprace**

Institut de Mathématique (IRMP)
Université Catholique de Louvain
Box L7.01.02
Chemin du Cyclotron, 2
1348 Louvain-la-Neuve
BELGIUM

Prof. Dr. Tim de Laat

Mathematisches Institut
Universität Münster
Einsteinstraße 62
48149 Münster
GERMANY

Dr. Mikael de la Salle

CNRS
Institut Camille Jordan, UMR 5208
Université Lyon 1
43 boulevard du 11 novembre 1918
69622 Lyon Cedex 07
FRANCE

Prof. Dr. Cornelia Drutu Badea

Mathematical Institute
Oxford University
Andrew Wiles Building
Woodstock Road
Oxford OX2 6GG
UNITED KINGDOM

Amandine Escalier

c/o Angela Loew/Elke Thiele
University of Münster
Mathematics Münster
Einsteinstrasse 62
48149 Münster
GERMANY

Prof. Dr. Mark E. Feighn

Department of Mathematics
Rutgers University
Newark, NJ 07102
UNITED STATES

Dr. Elia Fioravanti

Max-Planck-Institut für Mathematik
Vivatsgasse 7
53111 Bonn
GERMANY

Prof. Dr. Koji Fujiwara

Department of Mathematics
Kyoto University
Kitashirakawa, Sakyo-ku
Kyoto 606-8502
JAPAN

Prof. Dr. Damien Gaboriau

UMPA, UMR 5669, CNRS
École Normale Supérieure de Lyon
46, allée d'Italie
69364 Lyon Cedex 07
FRANCE

Dr. Giles Gardam

Mathematisches Institut
Universität Münster
Einsteinstraße 62
48149 Münster
GERMANY

Ido Grayevsky

Mathematical Institute
Oxford University
Andrew Wiles Building
Woodstock Road
Oxford OX2 6GG
UNITED KINGDOM

Dr. Vincent Guirardel

I. R. M. A. R.
Université de Rennes I
263 avenue du General Leclerc,
P.O. Box CS 74205
35042 Rennes Cedex
FRANCE

Prof. Dr. Ian Hambleton

Department of Mathematics and
Statistics
McMaster University
1280 Main Street West
Hamilton ON L8S 4K1
CANADA

Prof. Dr. Ursula Hamenstädt

Mathematisches Institut
Universität Bonn
Endenicher Allee 60
53115 Bonn
GERMANY

Dr. Camille Horbez

Laboratoire de Mathématiques
Université Paris Sud (Paris XI)
Batiment 307
91405 Orsay Cedex
FRANCE

Dr. David Hume

Mathematical Institute
Radcliffe Observatory Quarter
First Floor, Gibson Building
Woodstock Road
Oxford OX2 6HA
UNITED KINGDOM

Prof. Dr. Jarek Kedra

Department of Mathematical Sciences
University of Aberdeen
Fraser Noble Building
Aberdeen AB24 3UE
UNITED KINGDOM

Prof. Dr. Linus Kramer

Mathematisches Institut
Universität Münster
Einsteinstraße 62
48149 Münster
GERMANY

Prof. Dr. Peter H. Kropholler

Mathematical Sciences
University of Southampton
Southampton SO17 1BJ
UNITED KINGDOM

Dr. Robert Kropholler

Mathematics Institute
University of Warwick
Coventry CV4 7AL
UNITED KINGDOM

Prof. Dr. Gilbert Levitt

Département de Mathématiques
Université de Caen
LMNO
P.O. Box 5186
14032 Caen Cedex
FRANCE

JProf. Dr. Claudio Llosa Isenrich

Faculty of Mathematics
Karlsruhe Institute of Technology
Englerstr. 2
76131 Karlsruhe
GERMANY

Antonio Lopez Neumann

Centre de Mathématiques Laurent
Schwartz
École polytechnique
Route de Saclay
91128 Palaiseau Cedex
FRANCE

Prof. Dr. Alex Lubotzky

Einstein Institute of Mathematics
The Hebrew University
Givat Ram
Jerusalem 91904
ISRAEL

Dr. John Mackay

Department of Mathematics
University of Bristol
University Walk
Bristol BS8 1TW
UNITED KINGDOM

Anna Michael

Institut für Algebra und Geometrie
Otto-von-Guericke-Universität
Magdeburg
Universitätsplatz 2
39016 Magdeburg
GERMANY

Prof. Dr. Shahar Mozes

Institute of Mathematics
The Hebrew University
Givat-Ram
Jerusalem 91904
ISRAEL

Prof. Dr. Piotr Nowak

Institute of Mathematics of the
Polish Academy of Sciences
ul. Sniadeckich 8
00-656 Warszawa
POLAND

Dr. Damian L. Osajda

Institute of Mathematics
Wrocław University
pl. Grunwaldzki 2/4
50-384 Wrocław
POLAND

Prof. Denis Osin

Mathematics Department
Vanderbilt University
1326 Stevenson Center
Nashville TN 37240
UNITED STATES

Piotr Przytycki

Department of Mathematics and
Statistics
McGill University
805, Sherbrooke Street West
Montréal QC H3A 0B9
CANADA

Prof. Dr. Alan W. Reid

Department of Mathematics
Rice University
MS 136
Houston TX 77005-1892
UNITED STATES

Prof. Dr. Bertrand Rémy

Unité de Mathématiques Pures et
Appliquées
ENS de Lyon
46 allée d'Italie
69007 Lyon Cedex
FRANCE

Dr. Bakul Sathaye

Mathematisches Institut
Universität Münster
Einsteinstraße 62
48149 Münster
GERMANY

Prof. Dr. Roman Sauer

Institut für Algebra und Geometrie
Fakultät für Mathematik (KIT)
Englerstraße 2
76131 Karlsruhe
GERMANY

Prof. Dr. Petra Schwer

Institut für Algebra und Geometrie
Otto-von-Guericke-Universität
Magdeburg
Gebäude 03, Rm. 206a
Universitätsplatz 2
39106 Magdeburg
GERMANY

Prof. Dr. Zlil Sela

Department of Mathematics
The Hebrew University of Jerusalem
Office: Ross 73
Givat Ram
Jerusalem 9190401
ISRAEL

Prof. Dr. Yehuda Shalom

Department of Pure Mathematics
Tel Aviv University, Israel
Ramat Aviv
Tel Aviv 69978
ISRAEL

Dr. Alessandro Sisto

Department of Mathematics
Heriot-Watt University
Riccarton
Edinburgh EH14 4AS
UNITED KINGDOM

Dr. Anne Thomas

School of Mathematics and Statistics
The University of Sydney
Sydney NSW 2006
AUSTRALIA

Dr. Federico Vigolo

Fachbereich Mathematik und Informatik,
Universität Münster
Einsteinstraße 62
48149 Münster
GERMANY

Dr. Richard Wade

Mathematical Institute
Oxford University
Woodstock Road
Oxford OX1 3LB
UNITED KINGDOM

Prof. Dr. Karen L. Vogtmann

Mathematics Institute
University of Warwick
Zeeman Building, C2.05
Coventry CV4 7AL
UNITED KINGDOM

Prof. Dr. Nathalie Wahl

Department of Mathematical Sciences
University of Copenhagen, E 4.09
Universitetsparken 5
2100 København Ø
DENMARK