

Self-similar sets and self-similar measures in the p -adics

Kevin George Hare and Tomáš Vávra

Abstract. In this paper, we investigate p -adic self-similar sets and p -adic self-similar measures. We introduce a condition (C) under which p -adic self-similar sets can be shown to have a number of nice properties. It is shown that p -adic self-similar sets satisfying condition (C) are p -adic path set fractals. This allows us to easily compute the Hausdorff dimension of these sets. We further show that the set of p -adic path set fractals is strictly larger than this set of p -adic self-similar sets. The directed graph associated to p -adic self-similar sets satisfying condition (C) is shown to have a unique essential class. Moreover, it is shown that almost all points are eventually in the essential class. For p -adic self-similar measures satisfying this condition, we show that many results involving local dimension are similar to those of their real counterparts, with fewer complications. We next study the more general p -adic path set fractals, first showing that the existence of an interior point is equivalent to the set having Hausdorff dimension 1. We further show that often the decimation of p -adic path set fractals results in a set with maximal Hausdorff dimension.

1. Introduction

Let \mathbb{Q}_p be the p -adic numbers. We say that

$$F(x) = ax + d$$

with $F : \mathbb{Q}_p \rightarrow \mathbb{Q}_p$ is a linear contraction if $|F(x) - F(y)|_p < |x - y|_p$ for all $x \neq y$.

Let

$$\mathcal{F} = \{F_1, F_2, \dots, F_n\}$$

be a finite set of linear contractions. We say that \mathcal{F} is a p -adic iterated function system (p -adic IFS). By [28, Theorem 6], there exists a unique non-empty compact set $K \subseteq \mathbb{Q}_p$, called the *attractor* or p -adic self-similar set, such that

$$K = \bigcup_i F_i(K).$$

This is based upon the methods introduced in [23].

Mathematics Subject Classification 2020: 28A80 (primary); 11F85 (secondary).

Keywords: iterated function system, self-similar measures, p -adic numbers.

We say a p -adic IFS $\mathcal{F} = \{F_i\}_{i=1}^n$ satisfies condition (C) if

- for each $F_i \in \mathcal{F}$ we have $F_i(x) = \varepsilon_i p^{k_i} x + d_i$, with $\varepsilon_i \in \{-1, 1\}$, $k_i \in \mathbb{Z}$, $k_i \geq 1$, and $d_i \in \mathbb{Z}_p \cap \mathbb{Q}$,
- we have $n \geq 2$ and there exist i and j such that the fixed points of F_i and F_j are distinct.

This second requirement is needed to remove degenerate p -adic self-similar set containing only one point. In this paper, we focus on the case where the p -adic IFS satisfies condition (C). These objects have been studied in [25–28, 30].

Abram and Lagarias explored p -adic path set fractals in [1, 2]. Abram, Lagarias, and Slonim studied this in a more general setting in [3, 4]. To define a p -adic path set fractal, first, consider an automaton given by a directed graph G with vertices v_1, \dots, v_m . To each edge of this graph we associate an output from $\{0, 1, \dots, p - 1\}$. Consider the set of p -adic numbers associated to this directed graph from a starting vertex v_1 having p -adic representations given by the set of infinite words accepted by this automaton. This set of p -adic numbers is called a p -adic path set fractal.

In this paper, we study the relationship between p -adic path set fractals and p -adic self-similar sets. The notation used through this paper is introduced in Section 2. In Section 3, we consider p -adic self-similar sets satisfying condition (C). We show in Theorem 3.3 how to construct a transducer that takes as input a word $\sigma = a_0 a_1 a_2 \dots$ with $a_i \in \{1, 2, \dots, n\}^\omega$ and outputs the p -adic number associated with $F_{a_0} \circ F_{a_1} \circ F_{a_2} \circ \dots$. One consequence of this construction is that we are able to compute the Hausdorff dimension of p -adic self-similar sets satisfying condition (C). See Section 2.5 for a precise definition of Hausdorff dimension. Another easy consequence of Theorem 3.3 is the following proposition.

Proposition 1.1. *Let $\mathcal{F} = \{F_i\}_{i=1}^n$ be a p -adic IFS satisfying condition (C). Let K be the p -adic self-similar set associated to \mathcal{F} . Then, K is a p -adic path set fractal.*

In Section 4, we prove the following theorem.

Theorem 1.2. *Let $\mathcal{F} = \{F_i\}_{i=1}^n$ be a p -adic IFS satisfying condition (C). Let K be the p -adic self-similar set associated to \mathcal{F} . Then, there exists a deterministic finite automaton (DFA) with a unique essential class recognizing the language of p -adic expansions of \mathcal{F} .*

The precise definition of a DFA can be found in Section 2.2, and of an essential class in Section 2.3. As a corollary to this, we get that the set of p -adic self-similar sets satisfying condition (C) form a strict subset of p -adic path set fractals. In Section 4, we also show that almost all points in the attractor (with respect to Hausdorff measure) are associated to paths in the essential class (Theorem 4.10).

The study of p -adic self-similar measures and local dimensions is given in Section 5 and is analogous to self-similar measures and local dimensions on \mathbb{R} .

In Sections 6 and 7, we consider more general p -adic path set fractals. Theorem 6.1 shows that the existence of an interior point is equivalent to having positive Haar measure. This is not true in general for self-similar sets in \mathbb{R}^2 . In Section 7, we discuss decimation for p -adic path set fractals, showing that often the dimension of the decimation is maximal. Finally, in Section 8, we make some final comments and raise some open questions.

2. Notation

2.1. p -adic numbers

Fix a prime number p . The p -adic valuation $v : \mathbb{Q}^* \rightarrow \mathbb{Q}$ is defined as $v(\frac{a}{b}) = r$, where $\frac{a}{b} = p^r \frac{a'}{b'}$ with p being coprime to both a' and b' . The p -adic absolute value $|\cdot|_p : \mathbb{Q} \rightarrow \mathbb{Q}$ is defined as $|x|_p = p^{-v(x)}$ with $|0|_p = 0$. The term ‘‘absolute value’’ refers to certain axioms being satisfied, most notably $|xy|_p = |x|_p|y|_p$ and the (strong) triangle inequality $|x + y|_p \leq \max\{|x|_p, |y|_p\}$. Moreover, we have that $|x + y|_p = \max\{|x|_p, |y|_p\}$ whenever $|x|_p \neq |y|_p$. The p -adic absolute value is an ultra-metric inducing a topology on \mathbb{Q} . The topological completion of \mathbb{Q} with respect to $|\cdot|_p$ is called the field of p -adic numbers, denoted by \mathbb{Q}_p .

The standard way of expressing a p -adic number is through its p -adic expansion. This is an expression of the form $\sum_{i=k}^{\infty} x_i p^i$, where $k \in \mathbb{Z}$ and $x_i \in \{0, \dots, p - 1\}$ for all $i \geq k$. A p -adic expansion is eventually periodic if and only if the expanded number is rational, in which case the value can be computed through the closed formula for the sum of geometric series. In particular, $\mathbb{Z}_p \cap \mathbb{Q}$ is the set of p -adic integers with eventually periodic expansions. The set of p -adic integers is

$$\mathbb{Z}_p = \left\{ \sum_{i \geq 0} x_i p^i : x_i \in \{0, \dots, p - 1\} \right\}.$$

The integers \mathbb{Z} lie in \mathbb{Z}_p , with non-negative integers having finite representations, and negative integers having expansions where all but finitely many terms are $p - 1$.

See [6, 17, 24] for a more complete introduction to p -adic numbers.

2.2. Automata theory

A finite automaton \mathcal{A} on the finite set of symbols A is given by a finite set of states Q , by transitions $E \subseteq Q \times A \times Q$, and by an initial state $\mathbf{i} \in Q$. We denote the set of all finite words over an alphabet A as A^* . A finite word $\sigma = a_0 a_1 \cdots a_m \in A^*$ is said to

be accepted by \mathcal{A} if there exist transitions $(\mathbf{i}, a_0, q_0), (q_0, a_1, q_1), \dots, (q_{m-1}, a_m, q_m)$ all belonging to E . Finite automata traditionally also specify a set $F \subseteq Q$ of accepting states. In this case, we would additionally require the q_m above to satisfy $q_m \in F$. In this paper, we restrict our attention to finite automata where all states are accepting states, and the definition simplifies as above. These are also known as path sets [2]. A subset $L \subseteq A^*$ (usually called a language) is said to be recognized by a finite automaton \mathcal{A} if \mathcal{A} accepts precisely the elements of L . A *deterministic finite automaton* (DFA) has the property that, for every $q \in Q$ and $a \in A$, there is at most one $q' \in Q$ such that $(q, a, q') \in E$. A *non-deterministic finite automaton* (N DFA) is a finite automaton that is not deterministic. It is a classical result that if a language is recognized by a non-deterministic finite automaton, then there exists a deterministic finite automaton that also recognizes this language [5, Theorem 4.1.3]. We can associate to a finite automaton a finite graph on vertices Q . For each $(q, a, q') \in E$ we associate a directed edge (q, q') labeled by a . The automaton is then deterministic if, for each vertex q and each $a \in A$, at most one edge labeled a leaves q .

We next consider what it means for an infinite word to be accepted by a DFA or an N DFA. These are known as ω -automata. See, for instance, [18], in particular, Chapter 1 for an introduction and Chapter 3 for the relationship between deterministic and non-deterministic ω -automata. The usual notion of an ω -automaton requires an additional acceptance condition. This might be, for instance, that an accepting state is visited infinitely many times (Büchi automata), or that every infinitely often visited state belongs to an accepting set (Muller automata). These additional imposed technical conditions are not needed or studied in this paper. We consider only those automata where all states are accepting states. As such, these two notations of infinite words are equivalent and can be simplified. We say an infinite word $a_0 a_1 \dots$ with $a_i \in A$ is accepted by \mathcal{A} if all prefixes $a_0 \dots a_m$ are accepted by \mathcal{A} . A deterministic finite automaton can be constructed from a non-deterministic finite automaton using a subset construction. This can be found, for example, in [5, Theorem 4.1.3]. Let Q be the set of states of the N DFA. Each state in the DFA is an element of the power set of Q . Equivalently, each state in the DFA can be labeled by a subset of Q . We denote this set of states of the DFA as \bar{Q} . For a letter $a \in A$, the transition from a state $\bar{q}_1 \in \bar{Q}$ labeled by a is the state

$$\bar{q}_2 = \bigcup_{q \in \bar{q}_1} \{q' \in Q : (q, a, q') \in E\}.$$

In other words, for any path $a_0 a_1 \dots a_m$, the state reached by this path from $\{\mathbf{i}\}$ is all the states of Q that can be reached by this path in the non-deterministic version. It is not hard to see that the new automaton recognizes the same language. It is worth noting that the subset construction described above works in greater generality and is not limited to our restricted notation of N DFA.

A finite-state transducer is defined similarly to a finite-state automaton. In this paper, we only consider deterministic transducers. The key difference between a DFA and a deterministic transducer is that in addition to an alphabet A there is an output alphabet B . The transitions E satisfy

$$E \subseteq Q \times A \times Q \times B.$$

For a four-tuple (q_1, a, q_2, b) , we interpret q_1 as the start state of a transition and q_2 as an end state of a transition. We interpret a as the input alphabet and b as the output alphabet. This allows us to “read in” a finite or infinite word accepted by a finite-state transducer and output a finite or infinite word over the alphabet B .

For a more complete introduction to automata theory with infinite strings, see [18, 33].

2.3. Loop and essential classes

Let Q be the set of states of a DFA. Following the notation of [12, 19], we say that $L \subseteq Q$ is a *loop class* if for all q_1 and q_2 in L there exists a valid path in L from q_1 to q_2 . We say that L is a maximal loop class if there are no loop classes L' with $L \subsetneq L'$. We say that EC is an *essential class* if it is a maximal loop class, and further if all paths from $q \in EC$ stay in EC .

In the language of directed graphs, loop classes are also known as strongly connected components, and an essential class is a sink of the condensation of the directed graph.

2.4. Non-negative matrices

For a DFA \mathcal{A} with m states, we define its adjacency matrix $T = T_{i,j}$ for $1 \leq i, j \leq m$, where $T_{i,j}$ is the number of transitions from the state q_i to q_j . Defined this way, the i, j -th component of T^k is the number of different words s presented by paths of length k from q_i to q_j labeled by s . We immediately get that T is non-negative. If the graph of \mathcal{A} is strongly connected, we see that T is irreducible. If \mathcal{A} is not irreducible, we can permute T into a block triangular shape, where the diagonal blocks correspond to strongly connected components of \mathcal{A} .

The dominant eigenvalue value of a matrix M is known as the *spectral radius* and is denoted by $\rho(M)$. For M_1 and M_2 both $m \times m$ matrices, we have that if $0 \leq M_1 < M_2$, then there is an inequality of the spectral radii $\rho(M_1) \leq \rho(M_2)$, and in the case that M_2 is irreducible, we have $\rho(M_1) < \rho(M_2)$. See, for example, [31, Theorem 4.4.7]. We use this fact later in the proof of Theorem 1.2.

2.5. Hausdorff dimension

For any subset $X \subseteq \mathbb{Q}_p$, we define the diameter of X as

$$\text{diam}_p(X) := \sup_{x,y \in X} |x - y|_p.$$

For any $\delta > 0$ and any $d \geq 0$, we define

$$H_{\delta,p}^d(X) := \inf \left\{ \sum_{i=1}^{\infty} \text{diam}_p(X_i)^d : X \subseteq \bigcup X_i, \text{diam}_p(X_i) < \delta \right\}.$$

We define the *outer measure* $H_p^d(X)$ as

$$H_p^d(X) = \lim_{\delta \rightarrow 0} H_{\delta,p}^d(X).$$

The function $H_p^d(X)$ is decreasing in d . For most d , the value of $H_p^d(X)$ is either 0 or infinity. In fact, there is at most one value of d , where it can have a non-zero finite value.

For $X \subset \mathbb{Q}_p$, we define the *Hausdorff dimension*,

$$\dim_{H,p}(X) := \inf\{d \geq 0 : H_p^d(X) = 0\} = \sup\{d \geq 0 : H_p^d(X) = \infty\}.$$

Recall that K is the attractor of a p -adic IFS. For any $Y \subseteq K$, we define the *Hausdorff measure* $\mu_{K,p}$ with respect to K as $\mu_{K,p}(Y) = H_p^{\dim_{H,p}(K)}(Y)$. We show that when K is a p -adic self-similar set, then $0 < \mu_{K,p}(K) < \infty$. These definitions all have analogs over the real numbers (a field of characteristic 0). We denote these as diam_0 , $H_{\delta,0}^d$, H_0^d , $\dim_{H,0}$, and $\mu_{X,0}$. See [1, 25] for further details.

2.6. Languages

Let Q be a set of states of a DFA, $q \in Q$, and $L \subset Q$. Let \mathcal{A}_L be the sub-automaton of \mathcal{A} , where we restricted the set of allowable states to L . Typically, L is a loop class. We denote by $\mathcal{L}_L(q)$ the language accepted by the sub-automaton \mathcal{A}_L with initial state q . If L is not specific, then it is assumed to be Q . That is, $\mathcal{L}(q) = \mathcal{L}_Q(q)$. For a set of states $A \subseteq Q$, we define

$$\mathcal{L}(A) = \bigcup_{q \in A} \mathcal{L}(q) \quad \text{and} \quad \mathcal{L}_L(A) = \bigcup_{q \in A} \mathcal{L}_L(q).$$

In the second case, if A is not specified, then it is assumed to be L . That is, $\mathcal{L}_L = \mathcal{L}_L(L)$. We define the dimension of a language $\mathcal{L} \subset \{0, 1, \dots, p - 1\}^\omega$ as the dimension of the natural projection of \mathcal{L} to the p -adic integers.

3. Path set fractals and p -adic self-similar sets

Let $\mathcal{F} = \{F_i\}_{i=1}^n$ be a p -adic IFS satisfying condition (C). Let K be the p -adic self-similar set associated to \mathcal{F} . For each $x \in K$, there exists an infinite sequence $a_0 a_1 \dots$ with $a_i \in \{1, 2, \dots, n\}$ such that $x = \lim_{k \rightarrow \infty} F_{a_0} \circ F_{a_1} \circ \dots \circ F_{a_k}(0)$. This is a standard construction in the study of self-similar sets. See, for instance, [8, Section 1.1]. We say that $\sigma = a_0 a_1 a_2 \dots$ is an *address* of x . It is worth noting that x may have more than one address. For x having an address $a_0 a_1 a_2 \dots \in \{1, 2, \dots, n\}^\omega$, the reader can verify that

$$x = \sum_{j=0}^{\infty} \left(\prod_{i=0}^{j-1} \varepsilon_{a_i} p^{k_{a_i}} \right) d_{a_j}. \tag{3.1}$$

Further, every such sum on the right-hand side of (3.1) corresponds to an $x \in K$. As such, we have the following lemma.

Lemma 3.1. *The points of K are precisely*

$$\left\{ \sum_{j=0}^{\infty} \left(\prod_{i=0}^{j-1} \varepsilon_{a_i} p^{k_{a_i}} \right) d_{a_j} : (a_j) \in \{1, 2, \dots, n\}^\omega \right\}.$$

It is worth noting that the above sums are p -adic expansions only if

$$d_i \in \{0, 1, \dots, p - 1\} \quad \text{and} \quad \varepsilon_i = 1$$

for all i . Otherwise, the above sums are well defined but need some rewriting to give a p -adic number in the standard form.

Consider an automaton given by a directed graph G with vertices v_1, \dots, v_m . To each edge of this graph we associate an output from $\{0, 1, \dots, p - 1\}$. Then, the set of p -adic numbers associated to this directed graph from a starting vertex v_1 are the set of infinite words accepted by this automaton. These fractals are known as *p -adic path set fractals*, and they were first explored in [1, 2]. It is shown that the Hausdorff dimension of p -adic path set fractals exists and is equal to $\frac{\log(\lambda)}{\log(p)}$, where λ is the dominant eigenvalue of the adjacency matrix of the p -adic path set fractal.

We first give a simple example when $\varepsilon_i = 1$ and $k_i = 1$ to show how to rewrite points in K from an address σ into a standard p -adic representation. The set K in this example is also shown to be a p -adic path set fractal.

Example 3.2. Consider $p = 3$ and the p -adic IFS $\{F_0, F_1, F_3\}$ with $F_0(x) = 3x + 0$, $F_1(x) = 3x + 1$ and $F_3(x) = 3x + 3$. We have that

$$K = \left\{ \sum_{i \geq 0} 3^i d_i : d_i \in \{0, 1, 3\} \right\}.$$

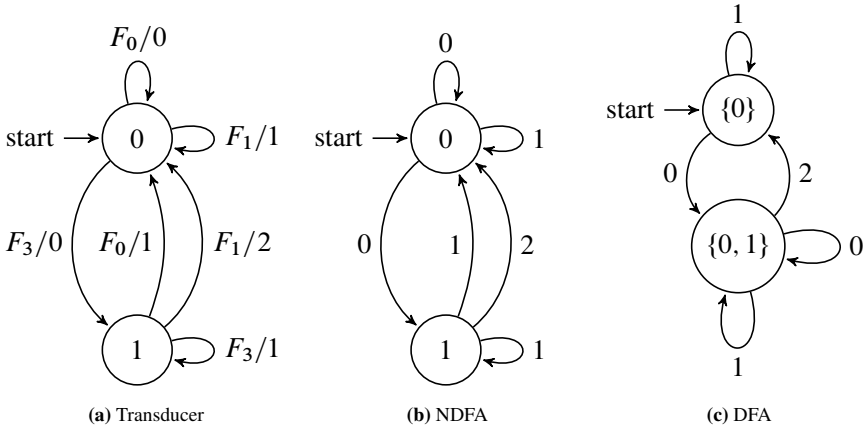

Figure 3.1. Transducer, NFA, and DFA for Example 3.2.

We can start rewriting $\sum_{i \geq 0} 3^i d_i$ from the least significant digits d_0, d_1, d_2, \dots . We note that the digit 3 is not an allowable digit in a 3-adic representation of a number. Because

$$3p^k + d_{k+1}p^{k+1} = (1 + d_{k+1})p^{k+1},$$

instead of the digit 3 we output 0 at the position of p^k , and remember the carry of 1. If $d_{k+1} \in \{0, 1\}$, we can resolve the carry. In case $d_{k+1} = 3$, the carry propagates further, and we use

$$4p^{k+1} = p^{k+1} + p^{k+2},$$

where p^{k+2} is the new carry. This procedure is visualized in Figure 3.1a.

Consider an $x = \sum_{i \geq 0} 3^i d_i \in K$ with $d_i \in \{0, 1, 3\}$. We start in state 0. If $d_0 = 0$, then we loop from state 0 to state 0 and output 0. If $d_0 = 1$, then we loop from state 0 to state 0 and output 1. If $d_0 = 3$, then we move from state 0 to state 1 and output 0. This last case corresponds to a carry of 1. After reading d_0, d_1, \dots, d_{m-1} , we are either in state 0 or state 1. If we are in state 0, then the reading of 0 or 1 corresponds to an output of 0 or 1, resp., and remains in state 0. Similar interpretations can be given if we are in state 1 and/or if we read in a 3.

Each edge of the transducer associated to the 3-adic self-similar set has both an input and output symbol (see Figure 3.1a). To describe the attractor as a 3-adic path set fractal, we associate to each edge the output symbol only. From this, we obtain an NFA recognizing the 3-adic expansions of elements of K . This is visualized in Figure 3.1b. We can then use the subset construction to get a DFA recognizing these 3-adic expansions. This is visualized in Figure 3.1c.

The idea from the previous example is the essence behind the following theorem.

Theorem 3.3. *Let $\mathcal{F} = \{F_i\}_{i=1}^n$ be a p -adic IFS satisfying condition (C). Let K be the p -adic self-similar set associated to \mathcal{F} . There exists a finite-state transducer that reads in the address of $x \in K$ and outputs the p -adic expansion of x . In particular, this transducer takes a sequence $a_0 a_1 \cdots \in \{1, \dots, n\}^\omega$ and outputs a sequence $x_0 x_1 \cdots \in \{0, 1, \dots, p-1\}^\omega$ with the property that if x has address $a_0 a_1 \cdots$, then $x = \sum_{i \geq 0} x_i p^i$.*

By applying this finite-state transducer to the language $\{1, \dots, n\}^\omega$, we show that K is recognized by a finite-state automaton. Further, the Hausdorff dimension of K is computable.

Proof. We consider three sub-cases, which have subtle differences in how they interact with the transducer.

- (1) For all i , $F_i(x) = px + d_i$ for $d_i \in \mathbb{Z}_p \cap \mathbb{Q}$.
- (2) For some i , $F_i(x) = p^{k_i} x + d_i$ with $k_i \geq 2$.
- (3) For some i , $F_i(x) = -p^{k_i} x + d_i$.

Before starting the main proof, we introduce some notation. Let $y = \sum_{i=0}^\infty y_i p^i \in \mathbb{Z}_p$ with $y_i \in \{0, 1, \dots, p-1\}$. We define $D(y) = y_0$. For $y \in \mathbb{Z}_p$, let

$$S(y) = (y - D(y))/p.$$

We see by the construction of $D(y)$ that $S(y) \in \mathbb{Z}_p$ and $y = D(y) + pS(y)$.

Similarly, for $k \geq 1$, define $D_k(\sum_{i=0}^\infty y_i p^i) = y_0 + y_1 p + \cdots + y_{k-1} p^{k-1}$. With abuse of notation, we will also write

$$D_k\left(\sum_{i=0}^\infty y_i p^i\right) = y_0 y_1 \cdots y_{k-1} \in \{0, 1, \dots, p-1\}^k.$$

This will be clear from the context. Define

$$S_k(x) = (x - D_k(x))/p^k. \tag{3.2}$$

In particular, $x = D_k(x) + p^k S_k(x)$.

Case (1). Assume that all maps are of the form $F_i(x) = px + d_i$ for some $d_i \in \mathbb{Z}_p \cap \mathbb{Q}$. Let $x \in K$ have address $\sigma = a_0 a_1 a_2 \cdots \in \{1, 2, \dots, n\}^\omega$. As $x \in \mathbb{Z}_p$, we can write $x = \sum_{i \geq 0} x_i p^i$ for some $x_i \in \{0, 1, \dots, p-1\}$. We noticed that the m -th digit x_m depends only on $d_{a_0}, d_{a_1}, \dots, d_{a_{m-1}}$. We now construct a transducer. We set the initial state $\mathbf{i} = 0 \in \mathbb{Z}_p \cap \mathbb{Q}$. Let s be a state reachable from \mathbf{i} . For each $i \in \{1, 2, \dots, n\}$, we add the state $s' = S(s + d_i)$ to the set of states reachable from \mathbf{i} . Note that we may have added s' at some previous step. We add a transition with input i and output o from s to s' (denoted by i/o or F_i/o , where $o = D(s + d_i)$).

For each reachable state s and each $i \in \{1, 2, \dots, n\}$, we repeat this process until such time as no new states are found. We show below why this set only contains finitely many states, which shows that this process terminates.

We next show that this transducer has the desired property. That is, this transducer takes a sequence $a_0a_1 \cdots \in \{1, \dots, n\}^\omega$ and outputs a sequence $x_0x_1 \cdots \in \{0, 1, \dots, p-1\}^\omega$ with the property that if x has address $a_0a_1 \cdots$, then $x = \sum_{i \geq 0} x_i p^i$.

Let $\sigma = a_0a_1 \cdots \in \{1, 2, \dots, n\}^\omega$ be an address of $x \in K$. Set $s_0 = \mathbf{i} = 0$. We inductively define $s_{i+1} = S(s_i + d_{a_i})$ and $x_i = D(s_i + d_{a_i})$. We note that x_i is the output of the transition from s_i to s_{i+1} on input a_i . By construction, $x_i \in \{0, 1, \dots, p-1\}$. Then, $x = \sum_{i \geq 0} d_{a_i} p^i = d_{a_0} + s_0 + \sum_{i \geq 1} d_{a_i} p^i$. We next write the constant coefficient in terms of D and S , and using the definition of s_1 , we get

$$x = D(d_{a_0} + s_0) + pS(d_{a_0} + s_0) + \sum_{i \geq 1} d_{a_i} p^i = x_0 + ps_1 + \sum_{i \geq 1} d_{a_i} p^i.$$

We continue in this fashion for the next term in the p -adic expansion to get

$$\begin{aligned} x &= x_0 + pD(d_{a_1} + s_1) + p^2S(d_{a_1} + s_1) + \sum_{i \geq 2} d_{a_i} p^i \\ &= x_0 + px_1 + p^2s_2 + \sum_{i \geq 2} d_{a_i} p^i. \end{aligned}$$

Repeating this argument, we get $x = \sum_{i \geq 0} x_i p^i$, as required. We see the right-hand side of this expression is a standard p -adic expansion with digits in $\{0, 1, \dots, p-1\}$.

Assume for a contradiction that there exists an infinite number of distinct states. Then, there exists an infinite sequence $a_1a_2 \cdots \in \{1, 2, \dots, n\}^\omega$ and an infinite set of distinct states $\{s_1 = 0, s_2, s_3, s_4, \dots\}$ such that $s_{i+1} = S(s_i + d_{a_i})$. We see that each d_i is both a rational number and a p -adic integer. Hence, we can write $d_i = \ell_i/d$ for some $\ell_i \in \mathbb{Z}$ and d a positive integer not divisible by p .

As $s_{i+1} = S(s_i + d_{a_i})$, we see that each s_i is also both a rational number and a p -adic integer. Further, we can write each $s_i = t_i/d$ for some $t_i \in \mathbb{Z}$ and d the same positive integer as above. By assumption, the t_i 's are distinct.

Let $d_{\max} = \max(0, d_1, d_2, \dots, d_n)$, where the maximum is taken with respect to the natural ordering on \mathbb{R} . As each d_i is a rational number, this is well defined. We claim that $s_i \leq d_{\max}$ for all i . To see this, we note that $s_1 = 0 \leq d_{\max}$, and by induction,

$$s_{i+1} = S(s_i + d_{a_i}) \leq \frac{s_i + d_{\max}}{p} \leq \frac{2d_{\max}}{p} \leq d_{\max}.$$

In a similar way we can show that $s_i \geq \min(0, d_1, d_2, \dots, d_n) =: d_{\min}$ for all i .

As there are only a finite number of rationals in \mathbb{Q} with denominator d and $d_{\min} \leq s_i \leq d_{\max}$, we see that there are a finite number of states.

Case (2). The above technique needs to be slightly modified when some maps are of the form $F_i(x) = p^{k_i}x + d_i$ for $k_i \geq 2$.

From equation (3.1), we see that the k_{a_i} -block of $\sum_{i \geq 0} p^{\sum_{j=0}^{i-1} k_{a_j}} d_{a_i}$ starting at position $1 + \sum_{j=0}^{i-1} k_{a_j}$ is determined by $d_{a_1}, d_{a_2}, \dots, d_{a_i}$ only.

As before, we add the initial state $\mathbf{i} = 0 \in \mathbb{Z}_p \cap \mathbb{Q}$. Let s be a state reachable from \mathbf{i} . As before, for each $i \in \{1, 2, \dots, n\}$, we add the state

$$s' = S_{k_{d_i}}(s + d_i)$$

to the set of states reachable from \mathbf{i} and a transition with input i and output o from s to s' , where $o = D_{k_i}(s + d_i)$.

We repeat this process until such time as no new states are found.

Similar to before, we can show that this transducer has the desired properties, and that there are only a finite number of states.

Case (3). The above technique again needs a modification if some of the maps have negative contractions. In this case, we keep track in a state s if we have had an even or odd number of maps with negative contractions before reaching this state. Those states with an even number of such maps are said to be in the positive orientation and those with an odd number are said to be in the negative orientation. This results in a doubling of the number of states, those of the form $(s, 1)$ in the positive orientation and those of the form $(s, -1)$ in the negative orientation.

We set the initial state $\mathbf{i} = (0, 1)$. Here, the “1” is indicating a positive orientation, which is the case for the initial state. Let $s = (u, \varepsilon)$ be a state reachable from \mathbf{i} . If $\varepsilon = 1$, then, for each $i \in \{1, 2, \dots, n\}$, we add the state $s' = S_{k_{d_i}}(u + d_i, \varepsilon_i)$ to the set of states reachable from \mathbf{i} and a transition with input i and output o from s to s' , where $o = D_{k_i}(u + d_i)$. If $\varepsilon = -1$, then, for each $i \in \{1, 2, \dots, n\}$, we add the state

$$s' = S_{k_{d_i}}(-u - d_i, -\varepsilon_i)$$

to the set of states reachable from \mathbf{i} and a transition with input i and output o from s to s' , where $o = D_{k_i}(-u - d_i)$.

We repeat this process until such time as no new states are found.

Similar to before, we can show this transducer has the desired properties, and that there are only a finite number of states.

We can use standard techniques for converting a non-deterministic automaton to a minimal deterministic automaton. See, for example, [5]. ■

Proof of Proposition 1.1. From Theorem 3.3, we get a transducer. By removing the input, we get an N DFA that accepts the language of the p -adic self-similar set. This N DFA defines a p -adic path set fractal. ■

Example 3.4. Consider a 5-adic self-similar set given by the two maps

$$A : x \mapsto -5x,$$

$$B : x \mapsto 5^2x + 1/2.$$

To construct our non-deterministic transducer, we start in state $\mathbf{i} = (0, 1)$ and consider the actions of maps A and B acting on this state.

In the case of the map A , we see that the output is 0 and the new state is $(0, -1)$. The “ -1 ” is a change of signs that is a result of the map being a negative contraction.

We indicate this on Figure 3.2a as a directed edge from $(0, 1)$ to $(0, -1)$ and labeling the edge $A/0$. That is, input A results in output 0 and a change of state from $(0, 1)$ to $(0, -1)$.

Next, we consider the action of B on state $(0, 1)$. It is worth noting that

$$1/2 = 3 + 2 \cdot 5 + (-1/2) \cdot 5^2.$$

This means that the output is 3, 2 (as we have a block of length 2), and the new state is $(-1/2, 1)$.

In a similar fashion, we consider the action of A and B on the two new states $(0, -1)$ and $(-1/2, 1)$. This results in four more directed edges and one new state to consider, namely, $(-1/2, -1)$. We repeat this process on any new states, until such time as no new states are found.

These are summarized in Figure 3.2a.

To produce the p -adic path set fractal (via an automata), we replace input/output combinations on an edge with the output only. In addition, for any output which is a block of length k , we insert $k - 1$ vertices to expand this out to a automaton with output of length one for each edge. In general, this resulting automaton need not be deterministic (although in this case it is). If it is a non-deterministic automaton, we can convert this to the minimal deterministic automaton using a standard process. See Figure 3.2b.

Labeling the vertices of the DFA in the order $(0, 1)$, $(0, -1)$, $(1/2, 1)$, $(-1/2, -1)$, a, b, c, d , we can next create an 8×8 adjacency matrix M for this automaton;

$$M = \begin{bmatrix} 0 & 1 & 0 & 0 & 0 & 1 & 0 & 0 \\ 1 & 0 & 0 & 0 & 0 & 0 & 0 & 1 \\ 0 & 0 & 0 & 1 & 1 & 0 & 0 & 0 \\ 0 & 0 & 1 & 0 & 0 & 0 & 1 & 0 \\ 1 & 0 & 0 & 0 & 0 & 0 & 0 & 0 \\ 0 & 0 & 1 & 0 & 0 & 0 & 0 & 0 \\ 0 & 1 & 0 & 0 & 0 & 0 & 0 & 0 \\ 0 & 0 & 0 & 1 & 0 & 0 & 0 & 0 \end{bmatrix}.$$

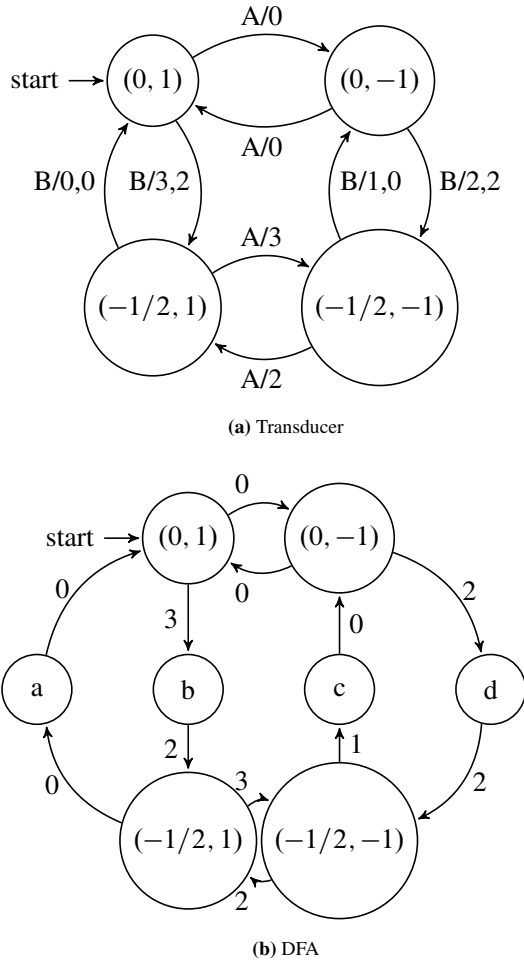

Figure 3.2. Transducer and DFA for Example 3.4.

This has a dominant eigenvalue of $\frac{1+\sqrt{5}}{2}$. Hence, utilizing the techniques of [1], we have that the Hausdorff dimension of this 5-adic self-similar set is

$$\frac{\log\left(\frac{1+\sqrt{5}}{2}\right)}{\log(5)} \approx 0.298994.$$

Let us conclude this section with the following remark. If one is interested only in the dimension of the attractor (and not, for instance, in the language of its points), there is an easier approach than that given by Theorem 3.3. One can modify the contractions by linear transformations to get an “easy case” with the same dimension.

Theorem 3.5. *Let $\mathcal{F} = \{F_i\}_{i=1}^n$ be a p -adic IFS satisfying condition (C). Let K be the p -adic self-similar set associated to \mathcal{F} . Then, there exists a linear map L so that $L \circ F_i \circ L^{-1}(x) = \varepsilon_i p^{k_i} x + d'_i$ with the following conditions.*

- (1) $d'_i \in \mathbb{Z}_p \cap \mathbb{Z}$.
- (2) If $\varepsilon_i = 1$, then $d'_i \geq 0$, and if $\varepsilon_i = -1$, then $d'_i \leq 0$.
- (3) There exists an i such that $d'_i = 0$.

The attractor for $\{L \circ F_i \circ L^{-1}\}$ is $L(K)$ and $\dim_{H,p}(K) = \dim_{H,p}(L(K))$.

In practice, such presentations often have fewer states. It is not immediately clear why this is the case, but we give a few heuristic reasons below. Condition (1) ensures that all states and d_i are integers, instead of rational numbers. Often when we have non-integer rational d_i , we need multiple states to handle the fact that rationals have periodic p -adic expansions. Conditions (2) and (3) combine to show that every state has a path back to the initial state \mathbf{i} . This has implications for the essential class (see Section 4).

Proof of Theorem 3.5. Let $L_1(x) = x + a$ and $F(x) = \varepsilon p^k x + d$ with $\varepsilon \in \{-1, 1\}$. One can check that $L_1 \circ F \circ L_1^{-1}(x) = \varepsilon p^k x + d + (1 - \varepsilon p^k)a$. Let $c_{\varepsilon,k} = 1 - \varepsilon p^k$. We notice that if $\varepsilon = -1$, then $c_{\varepsilon,k} > 0$, and otherwise, $c_{\varepsilon,k} < 0$. There exists an a such that $L_1 \circ F_i \circ L_1^{-1}(x) = \varepsilon_i p^{k_i} x + d'_i$ with $d'_i \in \mathcal{D}' \subseteq \mathbb{Q}_p$ finite, $d'_i \geq 0$ for $\varepsilon_i = 1$, $d'_i \leq 0$ for $\varepsilon_i = -1$, and at least one $d'_i = 0$. To see this, we see for large enough $a \in \mathbb{Q}$ we get that $d'_i \geq 0$ for $\varepsilon_i = 1$ and $d'_i \leq 0$ for $\varepsilon_i = -1$. By taking the minimal such a with this property, we see that at least one $d'_i = 0$.

We note that we do not at the moment have $d'_i \in \mathbb{Z}_p \cap \mathbb{Z}$. That is, L_1 satisfies property (2) and (3), but not necessary (1).

Let $L_2(x) = cx$ and $F(x) = \varepsilon p^k x + d'$. One can check that $L_2 \circ F \circ L_2^{-1}(x) = \varepsilon p^k x + cd'$. By choosing c as the lcm of the denominators of the d'_i from above, we see that $L_2 \circ L_1 \circ F_i \circ L_1^{-1} L_2^{-1}(x) = \varepsilon_i p^{k_i} x + d''_i$ with $d''_i \in \mathbb{Z}_p \cap \mathbb{Z}$. That is, these d''_i satisfy condition (1). Further, we see that d''_i continues to satisfy (2) and (3).

Setting $L := L_2 \circ L_1$ gives the desired result.

To see that the attractor of $\{L \circ F_i \circ L^{-1}\}$ is $L(K)$, first note that $K = \bigcup F_i(K)$ by definition. This gives that

$$\bigcup L \circ F_i \circ L^{-1}(L(K)) = L\left(\bigcup F_i(K)\right) = L(K),$$

as required. Nondegenerate linear maps preserve Hausdorff dimension, and hence, $\dim_{H,p}(K) = \dim_{H,p}(L(K))$. To see this, apply L to the cover X_i in the definition of $H_{\delta,p}^d$ in Section 2.5. Following through the calculations, we have $H_p^d(K) = \infty$ if and only if $H_p^d(L(K)) = \infty$. Similarly, $H_p^d(K) = 0$ if and only if $H_p^d(L(K)) = 0$. This gives the desired result. ■

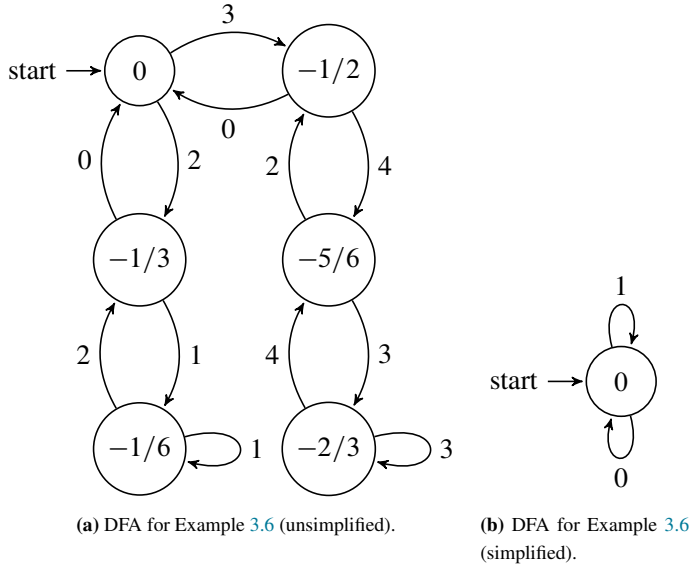

Figure 3.3. DFAs for Example 3.6.

Example 3.6. Consider the 5-adic self-similar set given by the two maps $A : x \rightarrow 5x + \frac{1}{2}$ and $B : x \rightarrow 5x + \frac{1}{3}$. Taking $L_1 : x \rightarrow x + \frac{1}{12}$, we get

$$L_1 \circ A \circ L_1^{-1}(x) = 5x + \frac{1}{6},$$

$$L_1 \circ B \circ L_1^{-1}(x) = 5x.$$

Taking $L_2 : x \rightarrow 6x$ gives

$$A'(x) := L_2 \circ L_1 \circ A \circ L_1^{-1} L_2^{-1}(x) = 5x + 1,$$

$$B'(x) := L_2 \circ L_1 \circ B \circ L_1^{-1} L_2^{-1}(x) = 5x.$$

Using [1, Theorem 3.1], we see that the Hausdorff dimension of this fractal is $\frac{\log 2}{\log 5}$. The DFA for the self-similar set given by $\{A, B\}$ and by $\{A', B'\}$ are given in Figure 3.3.

4. The Essential class

In Section 3, we constructed a transducer that outputs the language of expansions of points of a given p -adic self-similar set. From this transducer, we then constructed a deterministic finite automaton that accepts this language.

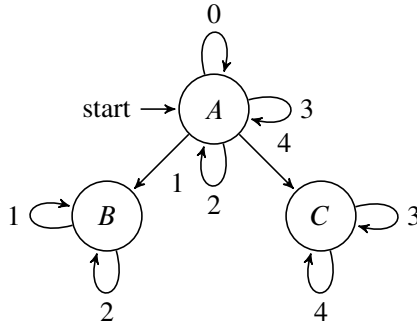

Figure 4.1. Path set fractal for Remark 4.3.

Recall that an essential class is a sink of the condensation of a directed graph associated to a DFA.

Essential classes have great impact on the study of self-similar sets in \mathbb{R} , especially self-similar measures (Section 5). An important and key result is that the minimal directed graph constructed from a self-similar set in \mathbb{R} satisfying the finite type condition has a unique essential class. See [21] and the references therein for a precise definition of finite type condition and proof of this result in \mathbb{R} . In this section, we prove Theorem 1.2, the analogous result for p -adic self-similar sets.

Definition 4.1. Let X be a p -adic path set fractal recognized by a DFA. We say that a point $x \in X$ is *essential* or an *essential point* if the path associated to this point through the minimal DFA is eventually in an essential class. We say a point $x \in X$ is *non-essential* if it is not essential.

Remark 4.2. In the case of p -adic self-similar sets satisfying condition (C), we will show that the essential class is unique. As this is not in general true for p -adic path set fractals, we say “an essential class” in the above definition, instead of “the essential class”.

Letting μ be the Hausdorff measure on this p -adic self-similar set K , we will also show that almost all $x \in K$ are essential points.

In Theorem 1.2, we show that for a p -adic self-similar set satisfying condition (C) that there is a unique essential class. In Theorem 4.10, we show that almost all points are essential points. Theorem 4.10 is needed to prove Theorem 1.2, and at the same time makes the result from Theorem 1.2 stronger. Combined we are showing that there is only one essential class, and that almost everything is associated to it.

Remark 4.3. It is worth noting that this property does not translate for a general path set fractal, as is illustrated in Figure 4.1. This p -adic path set fractal has two essential classes, namely, $\{B\}$ and $\{C\}$. Further, the dimension of this path set fractal is

$\log(3)/\log(p)$, whereas the dimension of the set of essential points is $\log(2)/\log(p)$. Hence, almost no points (with respect to the Hausdorff measure) are essential points.

We first give a technical lemma that will be useful in the next proof. Recall, in the construction of the states of the transducer, we keep track if we have had an even or odd number of maps with negative contractions before reaching this state. Those states with an even number of such maps are said to be in the positive orientation and those with an odd number are said to be in the negative orientation. The reader can verify that the following lemma.

Lemma 4.4. *Let $\mathcal{F} = \{F_i\}$ be a p -adic IFS satisfying condition (C) with the added restriction that $d_i \in \mathbb{Z}_p \cap \mathbb{Z}$. Let Q be the set of states of the transducer and $q \in Q$ a state in positive orientation. Let $\sigma = a_0 a_1 \cdots a_m$ and $F_\sigma = F_{a_0} \circ \cdots \circ F_{a_m}$, where F_σ is a map with a positive contraction. Then, $F_\sigma(x) = p^{k_\sigma} x + d_\sigma$ for some d_σ and $k_\sigma = \sum k_{a_i}$. Let S_k be defined as in (3.2). If the transducer reads $a_0 a_1 \cdots a_m$ starting in state q , then the final state will be $S_{k_\sigma}(q + d_\sigma)$.*

We next show that the NDFA constructed in the proof of Theorem 3.3 has a unique essential class under certain conditions.

Lemma 4.5. *Let $\mathcal{F} = \{F_i\}$ be a p -adic IFS satisfying condition (C) with the added restriction that $d_i \in \mathbb{Z}_p \cap \mathbb{Z}$. Let K be the p -adic self-similar set associated to \mathcal{F} . Then, there exists an NDFA with a unique essential class recognizing the language of p -adic expansions of \mathcal{F} .*

Proof. Let Q be the set of states of the transducer associated to \mathcal{F} . Here, \mathcal{F} may contain maps with both positive and negative contractions. Let $Q^+ \subseteq Q$ be the set of states in the positive orientation and $Q^- \subseteq Q$ be the set of states in the negative orientation. If $Q^+ = \{(0, 1)\}$, we are done. To see this, we note that any combination of maps with an even number of maps with $\varepsilon_i = -1$ is in Q^+ . Hence, $(0, 1)$ is a descendant of all states, and hence in every essential class. Further, all descendants of $(0, 1)$ are in every essential class. As $(0, 1)$ is the initial state, this shows that Q is the essential class.

Let $q_{\max} = \max q$ and $q_{\min} = \min q$, where the maximum and minimum are taken over all $(q, 1) \in Q^+$. We may assume that one of q_{\max} or q_{\min} is non-zero. Assume that $q_{\max} > 0$, the case where $q_{\min} < 0$ is similar. There exists a sequence of maps, $F_{a_0}, F_{a_1}, \dots, F_{a_m}$, such that $F_{a_0} \circ \cdots \circ F_{a_m}$ acting on $(0, 1)$ has a final state $(q_{\max}, 1)$. Call this map F_σ , and define k_σ and d_σ such that

$$F_\sigma(x) = p^{k_\sigma} x + d_\sigma.$$

Let $(q_1, 1), (q_2, 1) \in Q^+$. Let $(q'_i, 1)$ be the resulting state when applying F_σ to $(q_i, 1)$.

We note that if $q_1 < q_2$, then $q'_1 \leq q'_2$. To see this, we note that S_{k_σ} is a non-decreasing function, and $q'_i = S_{k_\sigma}(d_\sigma + q_i)$.

For all k , we note that S_k is superadditive. That is, for all $a, b \in \mathbb{Z}_p$, we have $S_k(a + b) \geq S_k(a) + S_k(b)$. To see this, we note that, for all $a, b \in \mathbb{Z}_p$,

$$D_k(a + b) \leq D_k(a) + D_k(b),$$

and further that

$$a + b = D_k(a + b) + p^k S_k(a + b) = D_k(a) + D_k(b) + p^k (S_k(a) + S_k(b)).$$

We see by construction of d_σ that $S_{k_\sigma}(d_\sigma) = q_{\max} > 0$. For all $q < 0, q \in \mathbb{Z}_p \cap \mathbb{Z}$, there exists a k_0 such that $S_k(q) = -1$ for all $k \geq k_0$. Choose ℓ such that

$$k_{\sigma^\ell} = \underbrace{k_\sigma + \dots + k_\sigma}_\ell \geq k_0.$$

Let q' be the state after applying σ^ℓ to q . Note that $S_{\sigma^\ell}(x) = p^{k_{\sigma^\ell}}x + d_{\sigma^\ell}$ for some $d_{\sigma^\ell} > 0$, and that $S_{k_{\sigma^\ell}}(d_{\sigma^\ell}) = q_{\max}$. This gives

$$S_{k_{\sigma^\ell}}(q + d_{\sigma^\ell}) \geq S_{k_{\sigma^\ell}}(q) + q_{\max} \geq -1 + q_{\max} \geq 0.$$

This implies that repeated applications of F_σ to any state in Q^+ eventually result in the state $(q_{\max}, 1)$.

Let $(q, -1) \in Q^-$. Let F_i be any map with $\varepsilon = -1$. We see that the application of F_i to $(q, -1)$ is in Q^+ . Hence, by the previous comment, all states in Q^- have $(q_{\max}, 1)$ as a descendant.

As $(q_{\max}, 1)$ is a descendant of all states, it is the descendant of all states in every essential class. Hence, it is in every essential class. Hence, all descendants of $(q_{\max}, 1)$ are in the same essential class. Hence, the essential class is unique. ■

Lemma 4.6. *Let $\mathcal{F} = \{F_i\}_{i=1}^n$ be a p -adic IFS satisfying condition (C). Let K be the p -adic self-similar set associated to \mathcal{F} . Then, there exists an NDFA with a unique essential class recognizing the language of p -adic expansions of \mathcal{F} .*

Remark 4.7. Note that Lemma 4.5 restricts $d_i \in \mathbb{Z}_p \cap \mathbb{Z}$, whereas Lemma 4.6 only restricts $d_i \in \mathbb{Z}_p \cap \mathbb{Q}$.

Proof of Lemma 4.6. All directed graphs with positive out-degree for every vertex have at least one essential class. As this is the case we are dealing with, it suffices to show that the essential class is unique.

Assume that q_1 and q_2 are states in possibly different essential classes. If there exists a map $F_i : x \mapsto \varepsilon_i p^{k_i} x + d_i$ with $\varepsilon_i = -1$, the child of a state under this map

has the opposite orientation of its parent. As such, we can assume without loss of generality that both q_1 and q_2 have positive orientation.

We first show that both q_1 and q_2 have descendants $q'_1 = (u_1, 1)$ and $q'_2 = (u_2, 1)$, where $u_1, u_2 \in \mathbb{Z}$.

If q_1 or q_2 are initially of the form $(u, 1)$ for $u \in \mathbb{Z}$, we take $q'_1 = q_1$ and $q'_2 = q_2$, as appropriate.

Otherwise, consider a path from the initial state \mathbf{i} to q_1 . This path is the image of the transducer acting on some word $\sigma \in \{1, 2, \dots, n\}^*$. As q_1 is in the positive orientation, we see that the word σ acting on a state preserves orientation. Assume that $q_1 = (r_1, 1)$ is a state labeled by a non-integer rational $r_1 = \frac{m_1}{n_1}$. It is worth noting that $p \nmid n_1$. As q_1 is a non-integer in $\mathbb{Z}_p \cap \mathbb{Q}$, we see that q_1 has an eventually periodic p -adic expansion. Assume that this expansion has period of length s_1 and pre-period of length t_1 .

Consider the state q'_1 given by the image of $\sigma^{n_1 s_1} = \underbrace{\sigma \sigma \dots \sigma}_{n_1 s_1}$ under the transducer. As this is a descendant of q_1 , we see that it is in the same essential class as q_1 . We next show that q'_1 , a descendant of q_1 , is an integer.

We adopt the notation $[x_0, x_1, x_2, \dots, x_m]$ with $x_i \in \{0, 1, \dots, p - 1\}$ to mean $\sum_{i=0}^m x_i p^i$, and the analogous notation for infinite p -adic expansions. For eventually periodic p -adic expansions, we use the notation

$$[x_0, x_1, \dots, x_{t-1}, \overline{x_t, \dots, x_{t+s-1}}],$$

where the x_0, \dots, x_{t-1} is the pre-periodic component of length t and x_t, \dots, x_{t+s-1} is the periodic component of length s . We can also consider different periods (of the same length) and longer pre-periods (containing parts of the period, or even repeated period). Namely, we can write q_1 as

$$q_1 = [x_0, x_1, \dots, x_{t_1-1}, x_{t_1}, \dots, x_{N-1}] + p^N \overline{[x_{t_1+j}, \dots, x_{t_1+s_1-1}, x_{t_1}, \dots, x_{t_1+j-1}]}$$

for some $N \in \mathbb{N}$, $j \in \{0, 1, 2, \dots, s_1 - 1\}$, and where the indices of the periodic part are taken modulo s_1 in the range $\{t_1, \dots, t_1 + s_1 - 1\}$. We note that

$$\overline{[x_{t_1+j}, \dots, x_{t_1+s_1-1}, x_{t_1}, \dots, x_{t_1+j-1}]}$$

is a rational number with denominator n_1 . Hence, we can write q_1 as

$$q_1 = c_0 + p^N \frac{e_0}{n_1}, \quad c_0, e_0 \in \mathbb{Z}.$$

Let $\sigma = a_0 a_1 \dots a_m \in \{1, 2, \dots, n\}^*$. We write $\ell(\sigma)$ for the length of the output of σ from the transducer. In particular, we have $\ell(\sigma) = \sum k_{a_i}$.

We can similarly write

$$p^{\ell(\sigma)}q_1 = c_1 + p^N \frac{e_1}{n_1}, \quad c_1, e_1 \in \mathbb{Z},$$

and, in general,

$$p^{\ell(\sigma)^i}q_1 = c_i + p^N \frac{e_i}{n_1}, \quad c_i, e_i \in \mathbb{Z}$$

for $i \in 0, 1, \dots, n_1s_1 - 1$.

We see that $e_i = e_{i+s_1}$ for $i = 0, 1, \dots, n_1s_1 - 1$. Hence, for any particular choice of $e^* \in \{e_0, e_1, \dots, e_{n_1s_1-1}\}$, the number of $i \in \{0, 1, \dots, n_1s_1 - 1\}$ such that $e_i = e^*$ is divisible by n_1 . Hence, the sum of the fractions with $e_i = e^*$ is an integer. As this is true for all e^* , we have that

$$q_1 + p^{\ell(\sigma)}q_1 + \dots + p^{\ell(\sigma)(n_1s_1-1)}q_1 \tag{4.1}$$

is an integer, and also, is precisely equal to q'_1 defined above as the image of $\sigma^{n_1s_1}$. To see the latter, remember that q_1 is encoded by σ (in the input alphabet); thus, $q_1 + p^{\ell(\sigma)}q_1$ is encoded by σ^2 . In conclusion, (4.1) is encoded by $\sigma^{n_1s_1}$.

We similarly construct $q'_2 = (u_2, 1)$, a descendant of q_2 and $u_2 \in \mathbb{Z}$.

This gives us two paths from the initial state \mathbf{i} to two states q'_1 and q'_2 in (possibly two different) essential classes. Further, q'_1 and q'_2 are both of the form $(u_1, 1)$ and $(u_2, 1)$ for some (possibly different) integers u_1 and u_2 . We next show that q'_1 and q'_2 have a common descendant, say, q^* . If $q'_1 = q'_2$, we are done; hence, we can assume that they are not equal. We can now use an argument similar to Lemma 4.5 to find a common descendant of q'_1 and q'_2 . As q_1 and q_2 are both descendants of all of their descendants (by the definition of an essential class), we see that q_1 and q_2 are in the same essential class.

This proves that the essential class is unique. ■

Example 4.8. Consider the self-similar set given by $p = 5$ and the maps $A : x \rightarrow 5x$ and $B : x \rightarrow 5x - 1/3$. The transducer for this self-similar set is given in Figure 4.2. It is clear from Figure 4.2 that there is one essential class. We show here how the proof of Lemma 4.6 can be applied to this example.

As both A and B preserve orientation, we see that all states have positive orientation. Consider the two states, $-1/3$ and $-2/3$, both in essential classes of the transducer. We see that $-1/3$ is the image of $\sigma_1 = BA$ under the transducer, and $-2/3$ is the image of $\sigma_2 = B$.

As before, we adopt the notation $[x_0, x_1, x_2, \dots, x_m]$ to mean $\sum_{i=0}^m x_i p^i$ and the equivalent notation for infinite p -adic expansions. For eventually periodic p -adic expansions, we use the notation

$$[x_0, x_1, \dots, x_{t-1}, \overline{x_t, \dots, x_{t+s-1}}],$$

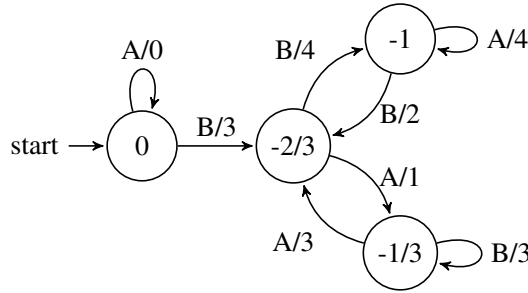

Figure 4.2. Transducer for Example 4.8.

where the x_0, \dots, x_{t-1} is the pre-periodic component and x_t, \dots, x_{t+s-1} is the periodic component.

We note that $-1/3 = \overline{[3, 1]} = 3 + 1 \cdot 5 + 3 \cdot 5^2 + 1 \cdot 5^3 + 3 \cdot 5^4 + \dots$ and $-2/3 = \overline{[1, 3]}$. We see that the periods of the p -adic expansions of both $-1/3$ and $-2/3$ are both of length 2, the pre-periodic components are of length 0, and the denominators in both cases are 3.

Let $N = t_1 + \ell(\sigma_1)s_1n_1 = 0 + 2 \cdot 2 \cdot 3 = 12$. We note that

$$\begin{aligned} -1/3 &= [3, 1, 3, 1, 3, 1, 3, 1, 3, 1, 3, 1] + (-1/3) \cdot 5^{12} = c_0 + (-1/3) \cdot 5^{12}, \\ -1/3 \cdot 5^2 &= [0, 0, 3, 1, 3, 1, 3, 1, 3, 1, 3, 1] + (-1/3) \cdot 5^{12} = c_1 + (-1/3) \cdot 5^{12}, \\ -1/3 \cdot 5^4 &= [0, 0, 0, 0, 3, 1, 3, 1, 3, 1, 3, 1] + (-1/3) \cdot 5^{12} = c_2 + (-1/3) \cdot 5^{12}, \\ -1/3 \cdot 5^6 &= [0, 0, 0, 0, 0, 0, 3, 1, 3, 1, 3, 1] + (-1/3) \cdot 5^{12} = c_3 + (-1/3) \cdot 5^{12}, \\ -1/3 \cdot 5^8 &= [0, 0, 0, 0, 0, 0, 0, 0, 3, 1, 3, 1] + (-1/3) \cdot 5^{12} = c_4 + (-1/3) \cdot 5^{12}, \\ -1/3 \cdot 5^{10} &= [0, 0, 0, 0, 0, 0, 0, 0, 0, 0, 3, 1] + (-1/3) \cdot 5^{12} = c_5 + (-1/3) \cdot 5^{12}. \end{aligned}$$

This gives us that the image of $\sigma_1\sigma_1\sigma_1\sigma_1\sigma_1\sigma_1$ is

$$c_0 + c_1 + \dots + c_5 + (-2) \cdot 5^{12} = [3, 1, 1, 3, 4, 4, 2, 1, 1, 3, 4, 4] + (-1) \cdot 5^{12}.$$

It is worth noting that the output from the transducer on $(BA)^6 = B, A, B, A, \dots, B, A$ is 3, 1, 1, 3, 4, 4, 2, 1, 1, 3, 4, 4, and we end in state -1 .

Similarly, for σ_2 we have $s_2 = 3$ and $n_2 = 2$. Taking $N_2 = t_2 + \ell(\sigma_2)s_2n_2 = 0 + 1 \cdot 2 \cdot 3 = 6$, we have

$$\begin{aligned} -2/3 &= [1, 3, 1, 3, 1, 3] + (-2/3) \cdot 5^6 = c'_0 + (-2/3) \cdot 5^6, \\ -2/3 \cdot 5 &= [0, 1, 3, 1, 3, 1] + (-1/3) \cdot 5^6 = c'_1 + (-1/3) \cdot 5^6, \\ -2/3 \cdot 5^2 &= [0, 0, 1, 3, 1, 3] + (-2/3) \cdot 5^6 = c'_2 + (-2/3) \cdot 5^6, \\ -2/3 \cdot 5^3 &= [0, 0, 0, 1, 3, 1] + (-1/3) \cdot 5^6 = c'_3 + (-1/3) \cdot 5^6, \end{aligned}$$

$$\begin{aligned}
 -2/3 \cdot 5^4 &= [0, 0, 0, 0, 1, 3] + (-2/3) \cdot 5^6 = c'_4 + (-2/3) \cdot 5^6, \\
 -2/3 \cdot 5^5 &= [0, 0, 0, 0, 0, 1] + (-1/3) \cdot 5^6 = c'_5 + (-1/3) \cdot 5^6.
 \end{aligned}$$

This gives us that the image of $\sigma_2\sigma_2\sigma_2\sigma_2\sigma_2\sigma_2$ is

$$c'_0 + c'_1 + c'_2 + c'_3 + c'_4 + c'_5 + (-3) \cdot 5^6 = [1, 4, 0, 4, 0, 4] + (-1) \cdot 5^6.$$

It is worth noting that the output from the transducer on $B^6 = B, B, B, B, B, B$ is 1, 4, 0, 4, 0, 4, and we end in state -1 .

At this point, we see that the state -1 is a common descendant of both states $-1/3$ and $-2/3$, and hence, $-1/3$ and $-2/3$ are in the same essential class.

If these were different (integer) states, then we would have needed to use the additional techniques from Lemma 4.5.

Notice that the adjacency matrix of a finite automaton is a non-negative matrix. From the Perron–Frobenius theorem [5, Theorem 8.3.7], such a matrix has a dominant eigenvalue λ corresponding to a non-negative eigenvector such that $\lambda \geq |\lambda'|$ for any other eigenvalue λ' .

Now, we can proceed to proving the main statement of this section.

Proof of Theorem 1.2. Let \mathcal{A} be the N DFA associated to the p -adic self-similar set with the set of states Q . We let $\bar{\mathcal{A}}$ be the deterministic representation of the p -adic self-similar set obtained by a subset construction, as described in Section 2.2. We denote \bar{Q} as the set of states of $\bar{\mathcal{A}}$. We note for all $\bar{q} \in \bar{Q}$ that $\bar{q} \subseteq Q$.

We denote by $EC \subseteq Q$ the unique essential class of the non-deterministic representation of K , as described in Lemma 4.5. We let $\overline{EC} \subseteq \bar{Q}$ be an essential class of the deterministic representation.

Recall that for $A \subset Q$ we defined $\mathcal{L}(A) = \bigcup_{q \in A} \mathcal{L}(q)$, where $\mathcal{L}(q)$ is the language accepted by an automaton \mathcal{A} with initial state q . We defined the dimension of a language $\mathcal{L} \subset \{0, 1, \dots, p - 1\}^\omega$ as the dimension of the natural projection of \mathcal{L} to the p -adic integers.

Similarly, we denote by $\bar{\mathcal{L}}(\bar{q})$ as the language accepted by the automaton $\bar{\mathcal{A}}$ with initial state \bar{q} . For a set of states $\bar{A} \subseteq \bar{Q}$, we define $\bar{\mathcal{L}}(\bar{A}) = \bigcup_{\bar{q} \in \bar{A}} \bar{\mathcal{L}}(\bar{q})$.

We see that

$$\dim_{H,p}(\mathcal{L}(EC)) = \max_{\overline{EC}} \dim_{H,p}(\bar{\mathcal{L}}(\overline{EC})) = \dim_{H,p}(K).$$

Here, the second maximum is taken over all possible essential classes in $\bar{\mathcal{A}}$. The first equality comes from the fact that the dimension of a finite union is the maximum of the dimensions within the union. The second equality can be seen from either part (2) or (3) of Theorem 4.10 (stated and proven below).

It follows from the subset construction that, for each state $q \in EC$, there is a state $\bar{q} \in \overline{EC}$ such that $q \in \bar{q}$. To see this, consider any path from the initial state \mathbf{i} to q in the NDFA. In the DFA coming from the subset construction, the same path from $\{\mathbf{i}\}$ ends in a state $\bar{q} \in \overline{EC}$ with $q \in \bar{q}$. It then holds that $\mathcal{L}(EC) \subseteq \overline{\mathcal{L}(EC)}$ because \overline{EC} contains every walk of EC (labeling-wise) and possibly more. As such, for all choices of \overline{EC} , we have that $\dim_{H,p}(K) = \dim_{H,p}(\mathcal{L}(EC)) \leq \dim_{H,p}(\overline{\mathcal{L}(EC)}) \leq \dim_{H,p}(K)$. Hence, $\dim_{H,p}(\overline{\mathcal{L}(EC)}) = \dim_{H,p}(K)$ for all essential classes \overline{EC} .

If $\mathcal{L}(EC) \neq \overline{\mathcal{L}(EC)}$, then \overline{EC} contains a path $w_1 \cdots w_n$, starting in some state \bar{q} , that is not a prefix of any member of $\mathcal{L}(EC)$. Moreover, as \overline{EC} is a loop class, we see that there exists a $u_1 u_2 \cdots u_m$ such that $w_1 \cdots w_n u_1 \cdots u_m$ begins and ends in the same state $\bar{q} \in \overline{EC}$. There exists a $\bar{q}' \in \overline{EC}$ such that $\bar{q}' \cap EC \neq \emptyset$. As \overline{EC} is a loop class, we may assume that \bar{q} has this property. Let $q \in \bar{q} \in \overline{EC}$ such that $q \in EC$. Construct \mathcal{A}' by appending to the directed graph of \mathcal{A} a path from q to q that outputs $w_1 \cdots w_n u_1 \cdots u_m$. We see that EC is the essential class of \mathcal{A}' . We define \mathcal{L}' on \mathcal{A}' in an analogous way to \mathcal{L} on \mathcal{A} . Consider the determinization of \mathcal{A}' , which we denote by $\overline{\mathcal{A}'}$. We define $\overline{\mathcal{L}'}$ on $\overline{\mathcal{A}'}$ in an analogous way to $\overline{\mathcal{L}}$ on $\overline{\mathcal{A}}$. We have $\mathcal{L}(EC) \subsetneq \mathcal{L}'(EC') \subseteq \overline{\mathcal{L}'(EC')} \subseteq \overline{\mathcal{L}(EC)}$.

Let $T, T', \overline{T}, \overline{T}$ be the transition matrices for $EC, EC', \overline{EC}', \overline{EC}$, respectively. Let $\lambda, \lambda', \overline{\lambda}', \overline{\lambda}$ be the dominant eigenvalues of these transition matrices. We see that

$$\dim_{H,p}(K) = \frac{\log(\lambda)}{\log(p)} = \frac{\log(\overline{\lambda})}{\log(p)} \quad \text{and} \quad \lambda < \lambda' \leq \overline{\lambda}' \leq \overline{\lambda},$$

a contradiction. The strict inequalities on the spectral radius are discussed in Section 2.4. Hence, $\mathcal{L}(EC) = \overline{\mathcal{L}(EC)}$ for all \overline{EC} .

We next show that we can identify the essential classes and substitute them for one representative without changing the language of the DFA.

Note that for any language recognized by a DFA there is a unique (up to isomorphism) minimal DFA that recognizes this language. Moreover, this minimal DFA can be obtained by iteratively identifying vertices that are *non-distinguishable* (see Hopcroft’s algorithm [22]). It is important to notice that, by following this procedure, to each “original” state q , there is a state \bar{q} in the next iteration such that $\mathcal{L}(q) = \overline{\mathcal{L}(\bar{q})}$. The same is then true for minimal DFA.

Therefore, any essential class EC can be replaced with a minimal representative EC^* , and for any $p \notin EC, q \in EC$, an edge $p \rightarrow q$ can be replaced with $p \rightarrow \bar{q} \in EC^*$ without changing the language this DFA recognizes. It is not hard to see that the resulting DFA is again deterministic, which concludes the proof. ■

Theorem 1.2 combined with Remark 4.3 proves the following corollary.

Corollary 4.9. *The set of p -adic IFS satisfying condition (C) form a strict subset of p -adic path set fractals.*

Theorem 4.10. Let $\mathcal{F} = \{F_i\}_{i=1}^n$ be a p -adic IFS satisfying condition (C). Let K be the p -adic self-similar set associated to \mathcal{F} . Let $K' \subseteq K$ be the set of non-essential points. Let $\mu_{K,p} = H_p^{\dim_{H,p}(K)}$ be the Hausdorff measure with respect to K . Then, the following are true.

- (1) $0 < \mu_{K,p}(K) < \infty$,
- (2) $\mu_{K,p}(K') = 0$,
- (3) $\dim_{H,p}(K') < \dim_{H,p}(K)$.

Remark 4.11. Consider the p -adic path set fractal from Remark 4.3. If we removed state C and all edges to or from state C , we see that the conclusions of the above theorem would not hold true, despite the DFA having a unique essential class. This is another example showing that the set of p -adic self-similar sets satisfying condition (C) forms a strict subset of p -adic path set fractals.

Remark 4.12. The proof of Theorem 1.2 used Theorem 4.10. As such, we will not assume there is a unique essential class in the proof of Theorem 4.10, but instead only assume that there is an essential class (which is true for all directed graphs where every vertex has a positive out-degree).

Proof of Theorem 4.10. It is worth noting that part (2) follows immediately from (3). It is easier to prove part (2) first and then, as a consequence of the proof of this part, conclude part (3).

As in [1], we define $\iota_p : \mathbb{Q}_p \rightarrow \mathbb{R}$ by

$$\iota_p\left(\sum_{i \geq k} x_i p^i\right) = \sum_{i \geq k} \frac{x_i}{p^i}.$$

As K is a path set fractal, we know from [1, Theorem 3.1] that

$$\dim_{H,p}(K) = \dim_{H,0}(\iota_p(K)) = \log(\lambda) / \log(p),$$

where λ is the spectral radius of the adjacency matrix of the minimal automaton associated to the path set fractal. We define $\mu_0 := H_0^{\dim_{H,0}(\iota_p(K))}$ as the Hausdorff measure with respect to $\iota_p(K)$. By [32, Theorem 3], it is known that $0 < \mu_0(\iota_p(K)) < \infty$.

We next show that

$$\mu_0(\iota_p(K)) \leq \mu_{K,p}(K) \leq 2p^{\dim_{H,0}(\iota_p(K))} \mu_0(\iota_p(K)),$$

which proves part (1): that $\mu_{K,p}(K)$ is positive and finite.

Let $d = \dim_{H,p}(K) = \dim_{H,0}(\iota_p(K))$. Consider

$$H_{\delta,0}^d(\iota_p(K)) := \inf \left\{ \sum_{i=1}^{\infty} \text{diam}_0(X_i)^d : \iota_p(K) \subseteq \bigcup X_i, \text{diam}_0(X_i) < \delta \right\}.$$

We define

$$\mathcal{C}_p = \{a + p^k \mathbb{Z}_p : k \geq 0, 0 \leq a \leq p^k - 1\}$$

and

$$\mathcal{C}_0 = \left\{ \left[\frac{a}{p^k}, \frac{a+1}{p^k} \right] : k \geq 0, 0 \leq a \leq p^k - 1 \right\}.$$

Note that for $0 \leq a \leq p^k - 1$ we have $\iota_p(a + p^k \mathbb{Z}_p) = [\frac{a}{p^k}, \frac{a+1}{p^k}]$; hence, there is a natural bijection between the countable set of sets \mathcal{C}_p and the countable set of sets \mathcal{C}_0 . It is worth noting that for an element of $a + p^k \mathbb{Z}_p \in \mathcal{C}_p$ that ι_p is not a bijection onto $[\frac{a}{p^k}, \frac{a+1}{p^k}]$ as there are a countable number of places where this map is 2-to-1. Hence, a cover of $\iota_p(K)$ by sets in \mathcal{C}_0 corresponds to a cover of K by sets in \mathcal{C}_p . That is, if $\mathcal{E}_0 \subset \mathcal{C}_0$ is a cover such that $\iota_p(K) \subset \bigcup_{E \in \mathcal{E}_0} E$, then $\{\iota_p^{-1}(E)\}_{E \in \mathcal{E}_0} \subset \mathcal{C}_p$ is a cover with $K \subset \bigcup_{E \in \mathcal{E}_0} \iota_p^{-1}(E)$.

For each $X_i \subset \mathbb{R}$, with $p^{-k} < \text{diam}_0(X_i) \leq p^{1-k}$, there exists two cylinders, $A_i, B_i \in \mathcal{C}_p$ of diameter p^{1-k} such that $X_i \subseteq \iota_p(A_i) \cup \iota_p(B_i)$. In the case that $X_i \in \mathcal{C}_0$, we can take $A_i = B_i$. Let $\{X_i\}$ be a cover of $\iota_p(K)$. Associate to each X_i the pair A_i, B_i such that $X_i \subseteq \iota_p(A_i) \cup \iota_p(B_i)$ with $p^{-k} \leq \text{diam}_0(X_i) \leq p^{1-k}$ and $p^{1-k} = \text{diam}_p(A_i) = \text{diam}_p(B_i)$. We see that $\{A_i, B_i\}$ is a cover of K . Further,

$$\begin{aligned} \text{diam}_0(X_i)^d &\leq \text{diam}_p(A_i)^d + \text{diam}_p(B_i)^d \\ &\leq (p \cdot \text{diam}_0(X_i))^d + (p \cdot \text{diam}_0(X_i))^d \\ &\leq 2p^d \text{diam}_0(X_i)^d. \end{aligned}$$

This gives us that

$$H_{\delta,0}^d(\iota_p(K)) \leq H_{p\delta,p}^d(K) \leq 2p^d H_{\delta,0}^d(\iota_p(K)).$$

Taking limits gives

$$\mu_0(\iota_p(K)) \leq \mu_{K,p}(K) \leq 2p^d \mu_0(\iota_p(K)),$$

which proves part (1) as desired.

To prove part (2), that $\mu_{K,p}(K') = 0$, we follow the proof of [20, Proposition 3.6]. Let

$$U_\ell = \{u \in \mathcal{C}_p : u \cap K' \neq \emptyset, u \text{ has diameter } p^{-\ell}\}.$$

For ease of notation, we define $\tilde{\mu}(A) = \mu_{K,p}(A \cap K)$. As $K' \subset K$, we see that $\tilde{\mu}(K') = \mu_{K,p}(K')$. Notice that $\tilde{\mu}(K') = \lim_{\ell \rightarrow \infty} \sum_{u \in U_\ell} \tilde{\mu}(u)$. We show that there exist $\lambda < 1$ and L such that

$$\sum_{u \in U_{\ell+L}} \tilde{\mu}(u) \leq \lambda \sum_{u \in U_\ell} \tilde{\mu}(u).$$

Taking limits, this gives

$$\tilde{\mu}(K') \leq \lambda \tilde{\mu}(K'),$$

which proves the result.

Set L equal to the number of vertices in the minimal DFA representation of the p -adic self-similar set. As $\tilde{\mu}$ is a measure, we see that for all a that

$$\tilde{\mu}(a + p^\ell \mathbb{Z}_p) = \sum_{b_\ell, b_{\ell+1}, \dots, b_{\ell+L-1}} \tilde{\mu}(a + b_\ell p^\ell + \dots + b_{\ell+L-1} p^{\ell+L-1} + p^{\ell+L} \mathbb{Z}_p).$$

For ease of notation, we write $\bar{b} = b_\ell p^\ell + \dots + b_{\ell+L-1} p^{\ell+L-1}$. Consider $u \in U_\ell$, and $a \in u$. We have

$$\tilde{\mu}(u) = \tilde{\mu}(a + p^\ell \mathbb{Z}_p) = \sum_{\bar{b}} \tilde{\mu}(a + \bar{b} + p^{\ell+L} \mathbb{Z}_p).$$

Further, as there are L vertices in the DFA, we see that there is at least one choice of \bar{b} such that

$$(a + \bar{b} + p^{\ell+L} \mathbb{Z}_p) \cap K' = \emptyset \quad \text{and} \quad (a + \bar{b} + p^{\ell+L} \mathbb{Z}_p) \cap K \neq \emptyset.$$

This follows as, for any state in the DFA, there exists a path of length at most L which terminates in an essential class. As $(a + \bar{b} + p^{\ell+L} \mathbb{Z}_p) \cap K \neq \emptyset$ and K is p -adic self-similar, we see that there is a scaled copy of K inside of $(a + \bar{b} + p^{\ell+L} \mathbb{Z}_p) \cap K$, and hence,

$$\tilde{\mu}(a + \bar{b} + p^{\ell+L} \mathbb{Z}_p) \geq p^{-L} \tilde{\mu}(K).$$

We set $\lambda = (1 - p^{-L})$. Hence, for $u \in U_\ell$ with $u \cap K' \neq \emptyset$, a ball of radius $p^{-\ell}$, and $u = a + p^\ell \mathbb{Z}_p$, we have that

$$\begin{aligned} \tilde{\mu}(u) &= \tilde{\mu}(a + p^\ell \mathbb{Z}_p) \\ &= \sum_{\bar{b}} \tilde{\mu}(a + \bar{b} + p^{\ell+L} \mathbb{Z}_p) \\ &= \sum_{\substack{\bar{b} \\ a + \bar{b} + p^{\ell+L} \mathbb{Z}_p \cap K' \neq \emptyset}} \tilde{\mu}(a + \bar{b} + p^{\ell+L} \mathbb{Z}_p) \\ &\quad + \sum_{\substack{\bar{b} \\ a + \bar{b} + p^{\ell+L} \mathbb{Z}_p \cap K' = \emptyset}} \tilde{\mu}(a + \bar{b} + p^{\ell+L} \mathbb{Z}_p) \\ &= \sum_{\substack{u' \in U_{\ell+L} \\ u' \subset u}} \tilde{\mu}(u') + \sum_{\substack{\bar{b} \\ a + \bar{b} + p^{\ell+L} \mathbb{Z}_p \cap K' = \emptyset}} \tilde{\mu}(a + \bar{b} + p^{\ell+L} \mathbb{Z}_p). \end{aligned}$$

We see in the last line that the second sum is strictly positive and bounded from below by $p^{-L}\tilde{\mu}(a + \mathbb{Z}_p) = p^{-L}\tilde{\mu}(u)$. Let $\lambda = 1 - p^{-L}$. This gives us that

$$\begin{aligned} \sum_{\substack{u' \in U_{\ell+L} \\ u' \subset u}} \tilde{\mu}(u') &= \tilde{\mu}(u) - \sum_{\substack{\bar{b} \\ a+\bar{b}+p^{\ell+L}\mathbb{Z}_p \cap K' = \emptyset}} \tilde{\mu}(a + \bar{b} + p^{\ell+L}\mathbb{Z}_p) \\ &\leq \tilde{\mu}(u) - p^{-L}\tilde{\mu}(u) \\ &= (1 - p^{-L})\tilde{\mu}(u) \\ &= \lambda\tilde{\mu}(u). \end{aligned}$$

Summing over all $u \in U_\ell$ gives

$$\sum_{u \in U_\ell} \sum_{\substack{u' \in U_{\ell+L} \\ u' \subset u}} \tilde{\mu}(u') = \sum_{u' \in U_{\ell+L}} \tilde{\mu}(u') \leq \lambda \sum_{u \in U_\ell} \tilde{\mu}(u),$$

as required.

To see part (3), we see from the above result that

$$\dim_{\mathbb{H},p} K' \leq \lambda^{1/L} \dim_{\mathbb{H},p}(K).$$

As $\lambda < 1$, the result follows. ■

5. p -adic self-similar measures

There is a well-established literature on self-similar measures μ on \mathbb{R}^n with support equal to a self-similar set. See, for instance, [19]. Let $F_0(x) = \beta x$ and $F_1(x) = \beta x + 1 - \beta$. Let $0 < \bar{p} < 1$. A common and classic example is μ_β , defined as the unique (up to scaling) measure satisfying

$$\mu_\beta = \bar{p}\mu_\beta \circ F_0^{-1} + (1 - \bar{p})\mu_\beta \circ F_1^{-1}.$$

If $\bar{p} = 1/2$, then this is known as unbiased; otherwise, it is known as biased.

If $\beta < 1/2$, then this is a Cantor measure with support on a Cantor set K satisfying $K = F_0(K) \cup F_1(K)$. If $\beta = 1/2$ and $\bar{p} = 1/2$, then this is the standard Lebesgue measure restricted to $[0, 1]$. If $1/2 < \beta < 1$, then this is known as a Bernoulli convolution and has been extensively studied [9, 10, 12–16].

Of particular interest is the local dimension of a point with respect to a self-similar measure.

Definition 5.1. Let μ be a measure and $x \in \text{supp}(\mu)$. We define the upper local dimension at x with respect to μ as

$$\overline{\dim}_{\text{loc}} \mu(x) = \limsup_{\varepsilon \rightarrow 0} \frac{\log(\mu(B_\varepsilon(x)))}{\log(\varepsilon)}.$$

Replacing \limsup with \liminf gives the lower local dimension. If the upper and lower local dimensions are equal, then we say that this is the local dimension.

The goal of this section is to demonstrate that a number of the techniques and results from self-similar measures on \mathbb{R} carry over to p -adic self-similar measures in a natural way, with respect to the upper and lower local dimensions.

Definition 5.2. A p -adic measure μ is an additive map from the set of compact open sets C of \mathbb{Q}_p to \mathbb{R}^+ . That is, if U_1, U_2, \dots, U_n is a set of disjoint open compact sets, then

$$\mu\left(\bigcup_{i=1}^n U_i\right) = \sum_{i=1}^n \mu(U_i).$$

Remark 5.3. It is worth noting that Definition 5.1 is well defined for such measures. We note that $B_\varepsilon(x) = \{y : |x - y|_p < \varepsilon\}$ are cylinders of p -adic numbers.

Consider the set of cylinders $a + p^N \mathbb{Z}_p$ in \mathbb{Q}_p . We see that these sets are both open and closed and form a basis of a topology for \mathbb{Q}_p .

The most common measure on \mathbb{Q}_p is the Haar measure, defined by

$$\mu(a + p^N \mathbb{Z}_p) = 1/p^N.$$

We can construct a p -adic self-similar measures in a similar way to their counterpart on \mathbb{R} . Let F_1, \dots, F_n be a series of contractions from $\mathbb{Q}_p \rightarrow \mathbb{Q}_p$. Let $\bar{p}_1, \dots, \bar{p}_n \in \mathbb{R}$ with $0 < \bar{p}_i < 1$ and $\bar{p}_1 + \dots + \bar{p}_n = 1$. We define a measure μ such that

$$\mu = \bar{p}_1 \mu \circ F_1^{-1} + \dots + \bar{p}_n \mu \circ F_n^{-1}. \tag{5.1}$$

It is further convenient to normalize this so that $\mu(K) = 1$, where K is the attractor of $\{F_1, F_2, \dots, F_n\}$. We define the (upper, lower) local dimensions for μ as before.

Example 5.4. The Haar measure restricted to \mathbb{Z}_p is a p -adic self-similar measure given by setting $F_i(x) = px + i$ for $i = 0, 1, \dots, p - 1$ and with equal probabilities $\bar{p}_i = 1/p$. In this case, all points have local dimension 1.

Example 5.5. Let $F_1(x) = 3x + 0$ and $F_2(x) = 3x + 2$ be maps from $\mathbb{Q}_3 \rightarrow \mathbb{Q}_3$. Let $\bar{p}_1 = \bar{p}_2 = 1/2$. Then, the measure

$$\mu = \bar{p}_1 \mu \circ F_1^{-1} + \bar{p}_2 \mu \circ F_2^{-1}$$

is the natural analog of the Cantor measure in the 3-adics. For a cylinder

$$C := c_0 + c_1 3 + \dots + c_{k-1} 3^{k-1} + 3^k \mathbb{Z}_3,$$

we see that $\mu(C) = 1/2^k$ if $c_0, c_1, \dots, c_{k-1} \in \{0, 2\}$ and 0 otherwise. For all points in the support of μ , we have that the local dimension is $\log(2)/\log(3)$.

For more complicated measures, we often have a range of possible local dimensions, instead of a singleton value.

Let $\sigma_1, \sigma_2 \in \{1, 2, \dots, n\}^*$. Define $\sigma_1\sigma_2$ as the concatenation of σ_1 with σ_2 , and σ_1^k as the k -fold concatenation of σ_1 with itself. Let $\sigma = a_0a_1 \cdots a_m \in \{1, 2, \dots, n\}^*$. We define $F_\sigma = F_{a_0} \circ \cdots \circ F_{a_m}$. Associated to each F_i is a probability \bar{p}_i such that $\sum \bar{p}_i = 1$. We define $\bar{p}_\sigma = \bar{p}_{a_0} \cdots \bar{p}_{a_m}$.

Assume that the p -adic IFS (and hence measure) is defined by the equicontractive maps $\{F_i\}$, where all maps are of the form $F_i(x) = px + d_i$ for some $d_i \in \mathbb{Z}_p \cap \mathbb{Q}$. A more complicated construction is possible p -adic self-similar IFS satisfying condition (C) by adapting the technique of [21].

Let K be the associated p -adic self-similar set. We know that $K = \bigcup F_i(K)$. It is not difficult to show that for any fixed m that

$$K = \bigcup_{\sigma \in \{1, 2, \dots, n\}^m} F_\sigma(K).$$

We see that if $\sigma \in \{1, 2, \dots, n\}^m$, then

$$F_\sigma(K) \subseteq x + p^m \mathbb{Z}_p$$

for some $x = x_0x_1x_2 \cdots \in \mathbb{Z}_p$. Further, as the center of every ball of the form $x + p^m \mathbb{Z}_p$ depends only on the first m terms of x , we may assume $x = x_0x_1x_2 \cdots x_{m-1}$. This gives us that $F_\sigma(K) \cap (x + p^m \mathbb{Z}_p) \neq \emptyset$ if and only if $F_\sigma(K) \subseteq x + p^m \mathbb{Z}_p$. This greatly simplifies our analysis. By a recursive application of equation (5.1), using a proof similar to [19, Lemma 3.5] or [13], we have that

$$\mu((x + p^m \mathbb{Z}_p) \cap K) = \sum_{\sigma \in \{1, 2, \dots, n\}^m, F_\sigma(K) \cap (x + p^m \mathbb{Z}_p) \neq \emptyset} \bar{p}_\sigma.$$

We show that there exists a finite set of matrices such that the measure of $c + p^m \mathbb{Z}_p$ is the sum of the entries of the product of m of these matrices. The product is explicitly determined by c .

With μ and \bar{p}_i defined as above,

$$\mu(c + p^m \mathbb{Z}_p) = \sum_{i=0}^{p-1} \mu(c + i \cdot p^m + p^{m+1} \mathbb{Z}_p).$$

Recall when we constructed the non-deterministic automaton that we labeled the states based on the remainder. Then, when we constructed our deterministic (albeit not necessarily minimal) automaton, we labeled the states as subsets of the set of remainders. Following [19, Section 3.2], we use these subsets of the set of remainders for the start state and end state of a transition to index the rows and columns of the transition matrices.

Consider two states in the deterministic automaton, say,

$$q_1 := \{r_1, \dots, r_k\} \quad \text{and} \quad q_2 := \{r'_1, \dots, r'_{k'}\}$$

such that there is a transition from q_1 to q_2 by output $c \in \{0, 1, \dots, p - 1\}$. We construct a $k \times k'$ matrix $T := T(q_1, q_2)$. We define

$$T[i, j] := \sum_{k \in H(i, j)} \bar{p}_k,$$

where the $H(i, j)$ is the set of all transitions S_k from states r_i to r'_j and with output of a . If this set is empty, then the sum is 0.

It is clear by construction that if $q_1 \rightarrow q_2 \rightarrow q_3$, then the transition matrices $T(q_1, q_2)$ and $T(q_2, q_3)$ have compatible dimensions for matrix multiplication. As both the NDFA and DFA contain a finite number of states, there are a finite number of matrices. Such a measure is said to satisfy the *finite type condition*.

We next show that the measure of a cylinder $c + p^k \mathbb{Z}_p$ can be determined by this matrix multiplication.

In a deterministic automaton, there is at most one edge associated to a particular output. As such, in the original transducer, we see that if for some $\sigma = a_0 a_1 \cdots a_m$ we have output $x_0 x_1 \cdots x_{m-1}$ we can determine exactly what the final state is in the DFA. We further see that this final state depends only on $x_0 x_1 \cdots x_{k-1}$. Let S_{m-1} be the state associated to the output $x_0 x_1 \cdots x_{m-2}$ and S_m the state associated to the output $x_0 x_1 \cdots x_{m-1}$. We are interested in the transition from S_{m-1} to S_m . Assume that $F_\sigma(K) \subseteq x + p^m \mathbb{Z}_p$. If $\sigma = a_0 a_1 \cdots a_m$, we define

$$\sigma^- = a_0 a_1 \cdots a_{m-1}.$$

We see that in the non-deterministic automaton that F_{w^-} is associated to a particular carry state, say, $r_i \in S_{m-1}$, and S_σ is associated to a carry state $r'_j \in S_m$. The weight contributed by this carry state is p_{a_m} . Hence, it is \bar{p}_{a_m} times the weight associated to the carry state r_i in $x_0 x_1 \cdots x_{m-2}$.

Example 5.6. Consider a measure μ with support the 3-adic self-similar set of Example 3.2. That is,

- $A : x \mapsto 3x$ with probability \bar{p}_0 ,
- $B : x \mapsto 3x + 1$ with probability \bar{p}_1 ,
- $C : x \mapsto 3x + 3$ with probability \bar{p}_3 .

See Figure 5.1 for a visual representation of the transducer with associated probabilities and the DFA with the associated transition matrices.

The local dimension at a point $x = \sum_{i \geq 0} x_i p^i$ can be computed by using the norm of the matrix product, normalized by the length, as before. For example, the

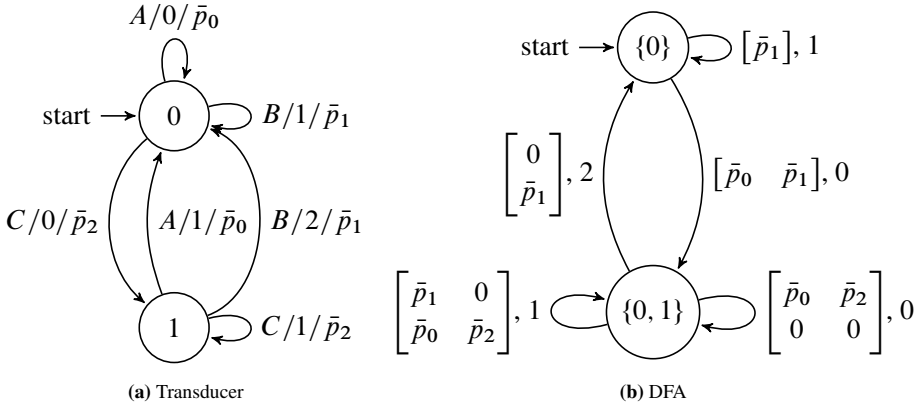

Figure 5.1. Transducer and DFA with associated probabilities and transition matrices for Example 5.6.

local dimension at $-1/8 = [\overline{1}, \overline{0}]$ would be given by

$$\begin{aligned} \dim_{\text{loc}}\mu(x) &= \lim_{k \rightarrow \infty} \frac{\log \left(\left\| [\bar{p}_1] [\bar{p}_0 \ \bar{p}_1] \left(\begin{bmatrix} \bar{p}_1 & 0 \\ \bar{p}_0 & \bar{p}_2 \end{bmatrix} \begin{bmatrix} \bar{p}_0 & \bar{p}_2 \\ 0 & 0 \end{bmatrix} \right)^{(k-2)/2} \right\| \right)}{\log(1/3^k)} \\ &= -\frac{\log(\bar{p}_0(\bar{p}_1 + \bar{p}_2))}{2 \log 3}. \end{aligned}$$

As the above example shows, the methods and technique from [12–15, 19] can be extended to p -adic self-similar measures in a natural way. The upper and lower local dimension of points in \mathbb{Z}_p can be computed using similar techniques. In \mathbb{R} , the computation of the upper local dimensions is complicated by the fact $\limsup \log(\mu[x - \varepsilon, x]) / \log(\varepsilon)$ need not equal $\limsup \log(\mu[x, x + \varepsilon]) / \log(\varepsilon)$. A similar comment holds for (lower) local dimensions. This is not an issue in the p -adic case, as all points are the center of the cylinder in which they are contained.

Adapting [20] and Theorem 4.10, we get the following proposition.

Proposition 5.7. *Let $\mathcal{F} = \{F_i\}_{i=1}^n$ be a p -adic IFS satisfying condition (C). Let K be the p -adic self-similar set associated to \mathcal{F} . Let μ be a self-similar measure defined on K as in (5.1). Let $K' \subseteq K$ be the set of points outside the essential classes. Then, the following are true.*

- (1) $0 < \mu(K) < \infty$.
- (2) $\mu(K') = 0$.

We say that μ has the positive row property if every row of every transition matrix has a non-zero entry. We say that a point is periodic if its p -adic representation is

eventually periodic. We say that a point x is a positive periodic point if it is periodic and the transition matrix associated to the period has strictly positive entries.

Adapting the proofs of [20], we get the following results for the p -adic self-similar measures.

Theorem 5.8 (Analogous to [20, Theorem 3.12]). *Suppose that μ is a p -adic self-similar measure satisfying the positive row property. Then, the set of lower local dimensions of μ at essential, positive, periodic points is dense in the set of all local dimensions of μ at essential points. A similar statement holds for the (upper) local dimensions.*

Theorem 5.9 (Analogous to [20, Theorem 3.13]). *Suppose that μ is a p -adic self-similar measure satisfying the positive row property. Assume that $x^{(n)}$ are essential, positive, periodic points. There is an essential point x such that*

$$\dim_{\text{loc}}\mu(x) = \limsup \dim_{\text{loc}}\mu(x^{(n)})$$

and

$$\dim_{\text{loc}}\mu(x) = \liminf \dim_{\text{loc}}\mu(x^{(n)}).$$

Theorem 5.10 (Analogous to [20, Theorem 3.14]). *Suppose that μ is a p -adic self-similar measure satisfying the positive row property. Let y, z be essential, positive, periodic points. Then, the set of local dimensions of μ at essential points contains the closed interval with endpoints $\dim_{\text{loc}}\mu(y)$ and $\dim_{\text{loc}}\mu(z)$.*

Corollary 5.11 (Analogous to [20, Corollary 3.15]). *Let μ be a self-similar measure satisfying the positive row property. Let*

$$I = \inf\{\dim_{\text{loc}}\mu(x) : x \text{ essential, positive, periodic}\}$$

and

$$S = \sup\{\dim_{\text{loc}}\mu(x) : x \text{ essential, positive, periodic}\}.$$

Then, $\{\dim_{\text{loc}}\mu(x) : x \text{ essential}\} = [I, S]$. A similar statement holds for the lower and upper local dimensions.

Theorem 5.12 (Analogous to [20, Theorem 3.18]). *Let μ be a p -adic self-similar measure satisfying the positive row property. Then, there exists an essential element x with*

$$\dim_{\text{loc}}\mu(x) = \dim_{\text{H},p}(K).$$

It is likely that many other results from self-similar measures also carry over in a similar or obvious way to p -adic self-similar measures.

6. p -adic path set fractals of dimension 1

Consider a subset of \mathbb{R} . It is easy to see that if the subset contains an interior point, then it necessarily contains an interval and the subset has positive Lebesgue measure and Hausdorff dimension 1. This is true in higher dimensions as well. That is, if a subset in \mathbb{R}^n contains an interior point, then it has positive Lebesgue measure and Hausdorff dimension n .

Surprisingly the converse is not true. In [11], an example is given of a self-similar set in \mathbb{R}^2 which has positive Lebesgue measure, but empty interior. A more explicit example using countably many maps is given in [7]. To the best of the authors' knowledge, it is not known in \mathbb{R} if an example exists of a self-similar set with positive measure and empty interior.

In this section, we show that p -adic path set fractals (and in particular p -adic self-similar sets satisfying condition (C)) satisfy a similar property. In particular, the existence of an interior point is equivalent to having Hausdorff dimension 1.

Theorem 6.1. *Let K be a p -adic path set fractal. Then, the following are equivalent.*

- (1) K has Hausdorff dimension 1.
- (2) The minimal deterministic finite automaton describing the p -adic expansions of K has a state q such that there are transitions q to q with output i for all $i \in \{0, 1, \dots, p - 1\}$.
- (3) There exists a finite word $x \in \{0, 1, \dots, p - 1\}^*$ such that the language of p -adic expansions of elements of K contains the language $x\{0, 1, \dots, p - 1\}^\omega$.

Proof. As $\dim_{H,p}([x]) = 1$ for all finite words x , we see that (3) implies (1).

Assume that K contains the language $x\{0, 1, \dots, p - 1\}^\omega$. Consider a path through the minimal DFA by x . As the DFA accepts this language, we see that this is a valid path. This results in a state q . We see that $\mathcal{L}(q) = \{0, 1, \dots, p - 1\}^\omega$. As we are assuming this is a minimal DFA, we see that we have transitions from q to q for all $i = 0, 1, \dots, p - 1$. Hence, (3) implies (2).

Assume that the minimal DFA has a state q with the property there is a transition from q to q for all $i = 0, 1, \dots, p - 1$. Consider x to be any word that starts at the initial state and ends at q . We see that $x\{0, 1, \dots, p - 1\}^\omega$ is contained in \mathcal{L} . Hence, (2) implies (3).

We next prove that (1) implies (2), which will complete the proof.

Consider the adjacency matrix of the minimal DFA. We first claim that we can permute the vertices of the DFA such that this matrix is upper block diagonal. To see this, we note that a condensation of a graph (a graph of its strongly connected components) is directed acyclic. Call this matrix B , and the diagonal blocks B_1, B_2, \dots . The

eigenvalues of B are the eigenvalues of the diagonal blocks B_1, B_2, \dots (in our case corresponding to strongly connected components). Thus, if K has Hausdorff dimension 1, then at least one of these diagonal blocks (say B_j) has eigenvalues p . We note that the maximal row sum of B , and hence B_j , is equal to p (as there is at most one directed edge corresponding to each output $i \in \{0, 1, \dots, p - 1\}$). As the eigenvalue of B_j is p , we see that the minimal row sum restricted to B_j is p . Let Q_j be the set of states associated to the rows of B_j . This gives us that for each $q \in Q_j$ and all transitions $i \in \{0, 1, \dots, p - 1\}$ there is a transition from q to $q' \in Q_j$. This gives us that the language associate with Q_j , \mathcal{L}_{Q_j} is equal to $\{0, 1, \dots, p - 1\}^*$. The minimal DFA associated to $\mathcal{L}_{Q_j} = \{0, 1, \dots, p - 1\}^*$ is a single state DFA. That is, $Q_j = \{q\}$ and there is a transition from q to q for all $i = 0, 1, \dots, p - 1$. ■

7. Decimation

In [1], Abram and Lagarias introduced the concept of decimation of a p -adic path set fractal. In particular, they observed that the class of p -adic path set fractals was closed under the operation of decimation.

Define the *decimation of a sequence by k with offset j* as

$$\psi_{j,k}(a_0, a_1, \dots) = (a_j, a_{j+k}, a_{j+2k}, \dots).$$

In this section, we investigate p -adic path set fractals under the process of decimation. Let K be the set of p -adic numbers of this path set fractal. It is often the case that, for sufficiently large k , and any offset j , the decimation of a p -adic path set fractal results in a language which is maximal. That is, for a loop class L we define $E(L)$ as the set of digits that occur in the language \mathcal{L}_L (then language associated to the sub-automaton restricted to states in L). We often have, for sufficiently large k , that the dimension of $\psi_{j,k}(K)$ is $\max \log(\#E(L)) / \log(p)$, where the maximum is taken over all loop classes.

Theorem 7.1. *Let K be a p -adic path set fractal with NDFA \mathcal{A} . Let L be a loop class of \mathcal{A} with the property that there exists a $q_L \in L$ and two paths starting and ending at q_L of coprime length. Let $E(L)$ be the set of digits that can occur in \mathcal{L}_L . Then, for sufficiently large k , we have the Hausdorff dimension of $\psi_{j,k}(K) \geq \log(\#E(L)) / \log(p)$.*

Moreover, if for all maximal loop classes L such a q_L exists, then for sufficiently large k we have the Hausdorff dimension of $\psi_{j,k}(K) = \max_L \log(\#(E(L))) / \log(p)$.

Remark 7.2. It is worth remarking here that the length of the path is measured by the length of the output, not by the number of edges traversed. This is not an issue for p -adic path set fractals, but one needs to be careful for p -adic self-similar sets.

Corollary 7.3. *Let T be the transition matrix of a loop class L of the NDFA of a p -adic path set fractal. Assume that there exists an m such that T^m is strictly positive. Let E be the set of digits that occur in \mathcal{L}_L . Then, for sufficiently large k , we have the Hausdorff dimension of $\psi_{j,k}(K) \geq \log(\#E)/\log(p)$.*

Proof. This follows from noting that if T^m is strictly positive, then so is T^{m+1} . As such, for all states q in the loop class, we have that there exist paths of both lengths m and $m + 1$ which both start and end at q . Hence, the conditions of Theorem 7.1 are satisfied and the result follows. ■

Proof of Theorem 7.1. Let $i \in E(L)$. Let $q \in L$ such that there are two paths of coprime length from q to q . Call these two paths p_1 and p_2 . There exists a $q_{2,i}$ such that there is a path from q to $q_{2,i}$ with final output i . Call this path $p_{3,i}$. In addition, there exists a path from $q_{2,i}$ to q . Call this path $p_{4,i}$.

For each i , considering the set of paths from the state q to the state q of the form $\{p_1, p_2\}^* p_{3,i} p_{4,i} \{p_1, p_2\}^*$. As p_1 and p_2 are coprime, we see that, for sufficiently large k , there exists a j (dependent on k) such that for all i there exists a path of length k and with output i in position j . Further, for sufficiently large N , we have that the state is reachable for all $j' \geq N$. This gives that $\psi_{j+j',k}(\mathcal{L}(L))$ has dimension $\log \#E(L)/\log p$.

This proves the inequality of the first part of the theorem, and the equality when maximizing over all maximal loop classes in the second part. ■

Example 7.4. Consider the path set fractal in Remark 4.3. We see that, for all j and all k , it is equal to its decimation. Further, the Hausdorff dimension of this set comes from the non-essential loop.

Example 7.5. If the conditions of Theorem 7.1 are not met, the result need not follow. Let $p = 3$. Consider the two maps

$$A : x \mapsto 9x + 3 \quad \text{and} \quad B : x \mapsto 9x + 6.$$

The non-deterministic and deterministic automata for this attractor are shown in Figure 7.1.

We see that all paths that start and end at the same state are of even length. Hence, we do not have two paths of coprime length, and the conditions of Theorem 7.1 are not satisfied. For any even number, the resulting decimation of the set has either dimension 0 or dimension $\log(2)/\log(3)$, depending on the parity of the offset. The dimension of K , as well as the decimation by an odd number, independent of the offset, is $\log(2)/\log(9)$.

Example 7.6. Consider the self-similar 3-adic fractal given by the two maps $A : x \mapsto 3x + 1$ and $B : x \mapsto 3x + 5$. One can quickly compute the transducer (see Figure 7.2).

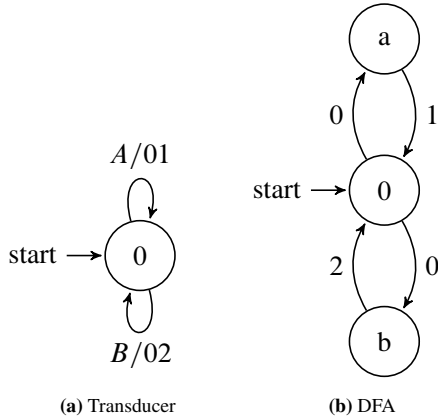

Figure 7.1. Transducer and DFA for Example 7.5.

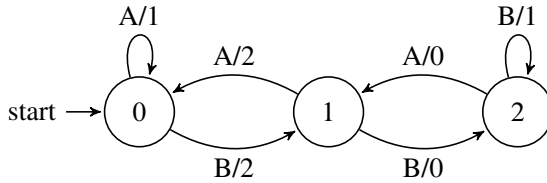

Figure 7.2. Transducer for Example 7.6.

A quick check shows that this is the DFA when removing the input, as there is no non-deterministic output.

There is only one maximal loop class, which is the entire set. The adjacency matrix is

$$T := \begin{bmatrix} 1 & 1 & 0 \\ 1 & 0 & 1 \\ 0 & 1 & 1 \end{bmatrix},$$

whose dominant eigenvalue is 2. Hence, the dimension of this set is

$$\dim_{H,p}(K) = \log(2)/\log(3) \approx 0.63092.$$

We see that $T^2 > 0$, and further that

$$E = \{0, 1, 2\}$$

are all the possible labels of the edges. Hence, by Corollary 7.3, we see for sufficiently large k that the decimation by k , independent of j , has

$$\dim_{H,p}(\psi_{j,k}(K)) = \log(3)/\log(3) = 1.$$

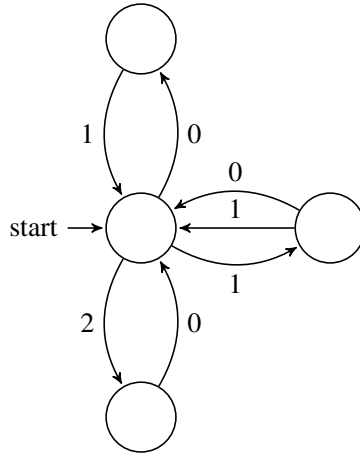

Figure 7.3. DFA for Remark 7.7.

Take, for example, $k = 3$. Consider the composition of maps $B \circ B \circ A$. We see that, regardless of the starting state, that the final output is 0 and the final state is 1. Similarly, under the map $B \circ B \circ B$, the final output is 1 and under the map $A \circ A \circ B$ the final output is 2. Hence, the decimation by 3, independent of the offset, has dimension 1.

Remark 7.7. It is worth noting that properties of decimation are not invariant under scalar multiplication and translations. This is also true in \mathbb{R} . We can define a path set fractal in \mathbb{R} with respect to some base b in the natural way. For example, consider the middle third Cantor set $C \subset [0, 1]$, written in base 3. This can be viewed as a path set fractal with one state, one transition from the state to itself with output 0, and one other transition from the state to itself with output 2. We see that the decimation of C , independent of both k and j , again gives C , and hence always has dimension $\log(2)/\log(3)$. Consider instead a scaled shifted version of C , namely,

$$C' := \frac{1}{2}C + \frac{1}{4}.$$

The directed graph for this path set fractal is given in Figure 7.3.

We have that the following.

- (1) If $k \geq 2$, k even and j odd, then $\dim_{H,0}(\psi_{k,j}(C')) = \frac{\log 3}{\log 3} = 1$.
- (2) If $k \geq 2$, k even and j even, then $\dim_{H,0}(\psi_{k,j}(C')) = \frac{\log 2}{\log 3}$.
- (3) If $k \geq 3$, k odd, then $\dim_{H,0}(\psi_{k,j}(C')) = \frac{\log 6}{\log 9}$.

8. Open questions and Comments

In this paper, we demonstrated that certain p -adic self-similar sets are in fact p -adic path set fractals. These self-similar sets are all recognizable by a DFA. We showed that the associated DFA has a unique essential class.

We gave examples where the contraction factor was $-p^{k_i}$ for some $k_i \geq 1$. It should be possible to extend these types of results to algebraic extensions of the p -adics.

In this paper, we restricted our investigation to contractions of the form

$$x \rightarrow \pm p^k x + d$$

for $k \geq 1$ and $d \in \mathbb{Q} \cap \mathbb{Z}_p$. If we consider a more general contraction

$$F_d(x) = px + d$$

for $d \in \mathbb{Z}_p$, we see that the (degenerate) IFS $\{F_d\}$ consists of a single point. This is the fixed point of F_d and is equal to $\frac{d}{1-p} \in \mathbb{Z}_p$. We note that there are only countably many p -adic path set fractals that accept a single point, whereas there are uncountably many F_d . As such, there exists a $d \in \mathbb{Z}_p$ such that the p -adic IFS $\{F_d\}$ is not a path set fractal. A similar observation can be made of the (degenerate) IFS $\{x \rightarrow dp x + 1\}$ for $d \in \mathbb{Z}_p$.

These examples are somewhat extreme cases. It may be (and probably is) possible to find more general contractions that preserve enough structure so that meaningful things can be said about the attractor. These would probably be analogous to IFS in \mathbb{R} , where the ratio of contraction is the inverse of a Pisot number. This would be an interesting avenue for further investigation.

We used the self-similar sets as a basis for creating p -adic self-similar measures. This follows a long history of self-similar measures in \mathbb{R} . We explored local dimension and showed that it is in fact easier to compute in this setting, with fewer complications. There are a number of questions about self-similar measures that have not been explored but could lead to interesting results. The most obvious of which is an exploration of L^q -spectrum for p -adic self-similar measures. See, for example, [29].

We next studied decimation. We gave sufficient conditions for when the decimation of a p -adic path set fractal has “maximal” dimension. We also gave examples of more general self-similar sets when this was not in fact true. It would be interesting to further the investigation under which more general conditions the decimation of a p -adic path set fractal has “maximal” dimension.

It was shown in [1] that the set of p -adic path set fractals is closed under the process of decimation. As p -adic self-similar sets are p -adic path set fractals, it is

clear that the decimation of a p -adic self-similar set is a p -adic path set fractal. It would be interesting to know under what conditions the decimation of a p -adic self-similar set is a p -adic self-similar set.

Acknowledgments. The authors would like to express their gratitude to the referee for their very insightful and helpful suggestions and comments. The paper and the results have been improved as a result.

Funding. Research of K. G. Hare was supported, in part, by NSERC Grant 2019-03930. Research of T. Vávra was supported, in part, by the University of Waterloo and NSERC Grant 2019-03930.

References

- [1] W. C. Abram and J. C. Lagarias, [p-adic path set fractals and arithmetic](#). *J. Fractal Geom.* **1** (2014), no. 1, 45–81 Zbl [1291.11107](#) MR [3166206](#)
- [2] W. C. Abram and J. C. Lagarias, [Path sets in one-sided symbolic dynamics](#). *Adv. in Appl. Math.* **56** (2014), 109–134 Zbl [1347.37027](#) MR [3194209](#)
- [3] W. C. Abram, J. C. Lagarias, and D. Slonim, [Interleaving of path sets](#). 2021, arXiv:[2101.02441](#)
- [4] W. C. Abram, J. C. Lagarias, and D. J. Slonim, [Decimation and interleaving operations in one-sided symbolic dynamics](#). *Adv. in Appl. Math.* **126** (2021), article no. 102160 Zbl [1477.37018](#) MR [4224069](#)
- [5] J.-P. Allouche and J. Shallit, [Automatic sequences. Theory, applications, generalizations](#). Cambridge University Press, Cambridge, 2003 Zbl [1086.11015](#) MR [1997038](#)
- [6] G. Bachman, [Introduction to p-adic numbers and valuation theory](#). Academic Press, New York, 1964 Zbl [0192.40103](#) MR [0169847](#)
- [7] S. Baker and N. Sidorov, [An infinitely generated self-similar set with positive Lebesgue measure and empty interior](#). *Proc. Amer. Math. Soc.* **147** (2019), no. 11, 4891–4899 Zbl [1429.28009](#) MR [4011521](#)
- [8] B. Bárány, K. Simon, and B. Solomyak, [Self-similar and self-affine sets and measures](#). Math. Surveys Monogr. 276, American Mathematical Society, Providence, RI, 2023 Zbl [07759243](#) MR [4661364](#)
- [9] J. Barral and D.-J. Feng, [On multifractal formalism for self-similar measures with overlaps](#). *Math. Z.* **298** (2021), no. 1-2, 359–383 Zbl [1469.28003](#) MR [4257091](#)
- [10] C. Bruggeman, K. E. Hare, and C. Y. Mak, [Multifractal spectrum of self-similar measures with overlap](#). *Nonlinearity* **27** (2014), no. 2, 227–256 Zbl [1286.28008](#) MR [3162609](#)
- [11] M. Csörnyei, T. Jordan, M. Pollicott, D. Preiss, and B. Solomyak, [Positive-measure self-similar sets without interior](#). *Ergodic Theory Dynam. Systems* **26** (2006), no. 3, 755–758 Zbl [1114.28005](#) MR [2237468](#)

- [12] D.-J. Feng, [Lyapunov exponents for products of matrices and multifractal analysis. I. Positive matrices](#). *Israel J. Math.* **138** (2003), 353–376 Zbl 1037.37023 MR 2031963
- [13] D.-J. Feng, [Smoothness of the \$L^q\$ -spectrum of self-similar measures with overlaps](#). *J. London Math. Soc. (2)* **68** (2003), no. 1, 102–118 Zbl 1041.28004 MR 1980246
- [14] D.-J. Feng, [The limited Rademacher functions and Bernoulli convolutions associated with Pisot numbers](#). *Adv. Math.* **195** (2005), no. 1, 24–101 Zbl 1078.11062 MR 2145793
- [15] D.-J. Feng, [Lyapunov exponents for products of matrices and multifractal analysis. II. General matrices](#). *Israel J. Math.* **170** (2009), 355–394 Zbl 1181.37073 MR 2506331
- [16] D.-J. Feng, K.-S. Lau, and X.-Y. Wang, [Some exceptional phenomena in multifractal formalism. II](#). *Asian J. Math.* **9** (2005), no. 4, 473–488 Zbl 1134.28008 MR 2216241
- [17] F. Q. Gouvêa, [p-adic numbers. An introduction](#). 2nd edn., Universitext, Springer, Berlin, 1997 Zbl 0874.11002 MR 1488696
- [18] E. Grädel, W. Thomas, and T. Wilke, [Automata, logics, and infinite games: A guide to current research](#). Lecture Notes in Comput. Sci. 2500, Springer, Berlin, 2002 Zbl 1011.00037 MR 2070731
- [19] K. E. Hare, K. G. Hare, and K. R. Matthews, [Local dimensions of measures of finite type](#). *J. Fractal Geom.* **3** (2016), no. 4, 331–376 Zbl 1396.28011 MR 3593551
- [20] K. E. Hare, K. G. Hare, and M. K. S. Ng, [Local dimensions of measures of finite type II: Measures without full support and with non-regular probabilities](#). *Canad. J. Math.* **70** (2018), no. 4, 824–867 Zbl 1457.28008 MR 3813514
- [21] K. E. Hare, K. G. Hare, and G. Simms, [Local dimensions of measures of finite type III—measures that are not equicontractive](#). *J. Math. Anal. Appl.* **458** (2018), no. 2, 1653–1677 Zbl 1376.28008 MR 3724747
- [22] J. Hopcroft, [An \$n \log n\$ algorithm for minimizing states in a finite automaton](#). In *Theory of machines and computations (Proc. Internat. Sympos., Technion, Haifa, 1971)*, pp. 189–196, Academic Press, New York, 1971 Zbl 0293.94022 MR 0403320
- [23] J. E. Hutchinson, [Fractals and self-similarity](#). *Indiana Univ. Math. J.* **30** (1981), no. 5, 713–747 Zbl 0598.28011 MR 0625600
- [24] N. Koblitz, [p-adic numbers, p-adic analysis, and zeta-functions](#). 2nd edn., Grad. Texts in Math. 58, Springer, New York, 1984 Zbl 0364.12015 MR 0754003
- [25] A. Kumar, M. Rani, and R. Chugh, [New 5-adic cantor sets and fractal string](#). *Springer-Plus* **2** (2013), article no. 654
- [26] M. L. Lapidus and L. Hùng, [The geometry of p-adic fractal strings: A comparative survey](#). In *Advances in non-Archimedean analysis*, pp. 163–206, Contemp. Math. 551, American Mathematical Society, Providence, RI, 2011 Zbl 1276.37053 MR 2882397
- [27] M. L. Lapidus, L. Hùng, and M. van Frankenhuysen, [p-adic fractal strings of arbitrary rational dimensions and Cantor strings](#). *p-Adic Numbers Ultrametric Anal. Appl.* **13** (2021), no. 3, 215–230 Zbl 1485.11138 MR 4308348
- [28] M. L. Lapidus and H. Lü', [Self-similar p-adic fractal strings and their complex dimensions](#). *p-Adic Numbers Ultrametric Anal. Appl.* **1** (2009), no. 2, 167–180 Zbl 1187.28014 MR 2566062
- [29] K.-S. Lau and S.-M. Ngai, [L^q-spectrum of the Bernoulli convolution associated with the golden ratio](#). *Studia Math.* **131** (1998), no. 3, 225–251 Zbl 0929.28005 MR 1644468

- [30] Y. Li and H. Qiu, [Fractal sets in the field of \$p\$ -adic analogue of the complex numbers](#). *Fractals* **27** (2019), no. 4, article no. 1950053 Zbl 1433.28019 MR 3980708
- [31] D. Lind and B. Marcus, [An introduction to symbolic dynamics and coding](#). Cambridge University Press, Cambridge, 1995 Zbl 1106.37301 MR 1369092
- [32] R. D. Mauldin and S. C. Williams, [Hausdorff dimension in graph directed constructions](#). *Trans. Amer. Math. Soc.* **309** (1988), no. 2, 811–829 Zbl 0706.28007 MR 0961615
- [33] D. Perrin and J.-É. Pin, [Infinite words. Automata, semigroups, logic and games](#). Pure Appl. Math., Amst. 141, Elsevier/Academic Press, Amsterdam, 2004 Zbl 1094.68052

Received 14 July 2023; revised 30 January 2024.

Kevin George Hare

Department of Pure Mathematics, University of Waterloo, Waterloo, ON, N2L 3G1, Canada;
kghare@uwaterloo.ca

Tomáš Vávra

Department of Algebra, Faculty of Mathematics and Physics, Charles University,
Sokolovská 83, 18600 Praha 8, Czech Republic; Department of Pure Mathematics,
University of Waterloo, Waterloo, ON, N2L 3G1, Canada; tvavra@uwaterloo.ca,
vavrato@gmail.com