



European Mathematical Society

NEWSLETTER No. 20

June 1996

Second European Congress of Mathematics	3
Report on the Executive Committee Meeting, March 8-10 1996	4
New Editorial Team	7
EMS Council Meeting	8
EMS Summer Schools	8
Report of the Committee for Mathematics Education (CME)	9
On the future of Mathematical publications	10
Letters to the Editor	12
Problem Corner	13
Euronews	20
Brief Reviews	26

Editors

Ivan Netuka

Mathematical Institute
Charles University
Sokolovská 83
18600 PRAGUE, CZECH REPUBLIC

David Singerman

Faculty of Mathematical Studies
The University
Highfield
SOUTHAMPTON SO17 1BJ, ENGLAND

* * * * *

Editorial Team Southampton:

D. Singerman, D.R.J. Chillingworth,
G.A. Jones, J.A. Vickers

Editorial Team Prague:

Ivan Netuka, Jirí Ràkosník, Vladimír Souček

* * * * *

Editor - Mathematics Education

W. Dörfler, Institut für Mathematik Univer-
sität Klagenfurt, Universitätsstraße 65-57 A-
9022 Klagenfurt, AUSTRIA

USEFUL ADDRESSES

President:

Jean-Pierre Bourguignon

IHES, Route de Chartres, F-94400 Bures-sur-
Yvette, France.

e-mail: jpb@ihes.fr

Secretary

Peter W. Michor,

Institut für Mathematik, Universität Wien,
Strudlhofgasse 4, A-1090 Wien, Austria.

e-mail: michor@esi.ac.at

Treasurer

A. Lahtinen,

Department of Mathematics, P.O.Box 4,
(Hallitusakatu 15), SF-00014 University of
Helsinki, FINLAND

e-mail: lahtinen@csc.fi

EMS Secretariat

Ms. T. Mäkeläinen

University of Helsinki (address above)

e-mail makelainen@cc.helsinki.fi

tel: +358-0-191 22883

telex: 124690

fax: +358-0-191-23213

Newsletter editors

D. Singerman, Southampton (address above)

e-mail ds@maths.soton.ac.uk

I. Netuka, Prague (address above)

e-mail netuka@karlin.mff.cuni.cz

Newsletter advertising officer

D.R.J. Chillingworth, Southampton (ad-
dress above)

e-mail drjc@maths.soton.ac.uk

NOTICE FOR MATHEMATICAL SOCIETIES

Please note labels are prepared during the second half of the month before the next issue. Would you please send your updated lists before this time.

Many thanks.

Ms T Mäkeläinen



SECOND EUROPEAN CONGRESS OF MATHEMATICS

Budapest, Hungary

July 21-27 1996

organized by the János Bolyai Mathematical Society
under the auspices of the European Mathematical Society

FINAL ANNOUNCEMENT

Scientific Programme

Plenary speakers

Noga ALON

Boris DUBROVIN

Dusa McDUFF

Alexander S. MERKURJEV

Stefan MÜLLER

Gérard BEN AROUS

János KOLLÁR

Jacques LASKAR

Vitali MILMAN

Jean-Pierre SERRE

Speakers at parallel sessions

L. Ambrosio

Ch. Bessenrodt

E. Bolthausen

L. Caporaso

I.A. Dynnikov

E. Hrushovski

J. Matousek

T. Nowicki

A. Platonov

H.P. Schlickewei

A. Shiryayev

G. Tardos

E. Zuazua

K. Astala

F. Béthuel

J. Bricmont

J. De Jong

L.H. Eliasson

J. Kaczorowski

L. Merel

A. Pastur

J. Pöschel

E. Scopolla

J.P. Solovej

J.-P. Tignol

R. Benedetti

P. Bjørstad

D. Burago

U. Dierkes

H. Hedenmalm

Ch. Lescop

R. März

R. Perez-Marco

L. Pyber

N. Simányi

A. Stipsicz

A. Veselov

Round Tables

Communication in Mathematics (*J. Körner*)

Mathematical Games (*D. Singmaster*)

Demography of Mathematicians

Women and Mathematics (*K. Haag*)

Public Image of Mathematics (*R. Bulirsch*)

Mathematics and Eastern Europe (*D. Cioranescu*)

Mathematical Education (*J.P. Kahane*).

How to register

If received before May 15, registration fee in Swiss Francs is 165 F for EMS members, 200 F for non-EMS members (on site 240 F for everybody) to be paid to :

MALÉV AIR TOURS, Roosevelt tér 2, H-1051 BUDAPEST (Hungary),
tel : +361 266 7836, fax : +361 266 6006, e-mail : ecm2mat@math-inst.hu.

EUROPEAN MATHEMATICAL SOCIETY

Report on the Executive Committee Meeting
Bures sur Yvette (France) March 8-10, 1996

Eva Bayer Fluckiger, Jean-Pierre Bourguignon, Alberto Conte, Aatos Lahtinen, László Márki, Peter Michor, Andrzej Pelczar, V.A. Solonnikov and David Wallace were present. Isabel Labouriau was excused.

Roland Bulirsch (Chairperson of the round table "Public image of mathematics" at ECM2), Mireille Chaleyat-Maurel (Public Relations Officer), Gerd Fischer (Editor of the Mitteilungen der DMV), Giovanni Monegato (Chairperson of the Summer School Committee), Albert Shiryaev (Diderot Mathematical Forum "Mathematics and Finance", Moscow), Christophe Soulé (Summer School Committee), Bernd Wegner (FIZ Karlsruhe), Tuulikki Mäkeläinen (Secretary of the European Mathematical Society) were invited.

The Executive Committee thanks the I.H.E.S. for perfect arrangements and hospitality during the meeting.

SCIENTIFIC ACTIVITIES

Second European Congress of Mathematics ECM2 July 22–26, 1996 Budapest (Hungary)

THERE IS STILL TIME TO REGISTER! *

The Congress e-mail address is : ecm2jbms@math-inst.hu

◇ *Speakers*

All plenary speakers (N. Alon, G. Ben Arous, D. McDuff, B. Dubrovin, J. Kollár, J. Laskar, A. Merkurjev, V. Milman, S. Müller, J.-P. Serre) and 38 section speakers have accepted. The list of speakers will be made public by the organising committee of ECM2.

◇ *Round Tables*

The final list is the following:

COMMUNICATION IN MATHEMATICS (J. Körner)

MATHEMATICAL GAMES (D. Singmaster)

DEMOGRAPHY OF MATHEMATICIANS (J.-P. Bourguignon, D. Wallace)

WOMEN AND MATHEMATICS (K. Haag)

PUBLIC IMAGE OF MATHEMATICS (R. Bulirsch)

MATHEMATICS AND EASTERN EUROPE (D. Cioranescu)

EDUCATION (J.-P. Kahane)

◇ *Proceedings*

The editors of the proceedings will be as follows:

Plenary lectures: first volume, edited by D. Szasz.

Section lectures: second volume, edited by G. Katona and A. Balog.

Round tables: third volume, edited by A. Recski.

Birkhäuser will publish the Proceedings.

* See advertisement on page 3

Diderot Mathematical Forum

The first Conference of this series will take place on September 24–25, 1996 in the three towns, London, Moscow and Zurich.

The International Statistical Institute meeting (Latsis) will be held simultaneously in Zurich, with a day or two in common as a joint venture.

Towards a European Bibliographical Database

The contract between FIZ and EMS is to be signed. France has officially joined the cooperation with Zentralblatt. CD-Rom access on site exists on-line for licensed persons. There is now an improved interface. In the near future there will be CD-Rom of Zentralblatt free access for two weeks, later free demo access only for five hits. The contents of the years from now back to 1931 are now electronically available. An attempt has to be made to have the database accepted as a Large Facility by the EU. All members of EU countries should try to persuade their government persons concerned to act for this project.

Summer Schools

The Executive Committee decided that the level should be predoctoral, the size 100-120 persons, the site rotating and that the role of the EMS should be visible. Calls for applications should be asked for in the server and in the Newsletter. Existing Summer School series can apply if they make a special effort to be European in character.

INFORMATION SERVICES

Server (EMIS)

J. Coates made a proposal which is accepted by the Executive Committee, on Current Awareness of Mathematical Publications. The project would contain one page summaries evaluated by a referee, to be available on the server and simultaneously in the database. Copyright would be with the EMS for one year, then transferred to Zentralblatt: a question to be negotiated. LMS, Springer, SMF have reacted positively. It should be considered as a service to publishers and societies as well as to mathematicians. The structure has to be defined and agreed upon.

RELATIONS WITH EUROPEAN INSTITUTIONS

Club for the Organisation of the Strategy of Mathematics in Europe (COSME)

The Executive Committee decided to participate in the founding of a Club to lobby for mathematics. This Club will link academic institutions, European research agencies and corporations with an interest in mathematics. The goals are the following:

- to obtain modifications of the Fourth Framework Programme of the European Union to take into account the specific features of mathematics;
- to prepare a proposal for the Fifth Framework Programme of the European Union;
- to help bring out short notes on focused themes of common interest;
- to foster the establishment of bilateral or multilateral contacts between its partners in order to facilitate the circulation of mathematicians between various sectors of activities;
- to improve the visibility of the discipline in European media;

- to contribute to a better knowledge of the demography of mathematicians in the European mathematical community.

The President has initiated some contacts; the coordinator is Daniel Gabay (France). Suggestions for contacts in the different countries are welcome.

European Research Conferences (EURESCO)

The series is running well. The specificity of these conferences resides in their European representation, leadership in the field and a public of young mathematicians. The first Conference on Algebra and Discrete Mathematics will take place in July 1996.

EU Tests

The European Union Commission has introduced a programme to which J.P. Boudine and Willi Paillet have submitted a preliminary proposal for building a system of tests within the EU, to enable for adults to test the level of their knowledge in mathematics. It is mainly designed for job applications, not for educational purposes. It is not planned that it should become compulsory but rather remain advisory.

The plan:

- the future server is to contain examinations which candidates can retrieve, and take;
- the user must be identified;
- there will be modules of tests and results are recorded in the server;
- the purpose is to test familiarity, knowledge of subjects;
- the tests are multiple choice; their quality should be guaranteed.

The Executive Committee agreed that EMS should take part in the refereeing of the tests as an independent body.

This plan will be presented at the round table on education in Budapest.

WMY 2000

Among several proposals for the year 2000, the Executive Committee decided to support a first European-Arab Congress of Mathematics in Alhambra (Granada, Spain). Financial aid could be sought from EU, UNESCO with the help of EMS.

The WMY 2000 Committee will meet in Budapest.

LIFE OF THE SOCIETY

Council Meeting, Budapest, July 20–21, 1996

◇ Delegates for individual members

There were 11 seats to be filled by election, and there were eleven candidates, so it was decided according to the statutes to declare all candidates elected without postal voting. The new delegates for the period 1996–1999 are: G. Anichini (Italy), G. Bolondi (Italy), B. Branner (Denmark), J.-M. Deshouillers (France), K. Habetha (Germany), M. Karoubi (France), T. Kuusalo (Finland), A. Lahtinen (Finland), L. Márki (Hungary), R. Piccinini (Italy), D. Puppe (Germany).

Corporate Members

◇ *Latvian Mathematical Society*

The Executive Committee recommends that the Council accept the membership of the Latvian Society.

◇ *Spanish Mathematical Society, Union of Societies of Mathematicians, Physicists and Astronomers of Yugoslavia*

Their membership should be considered at the Council meeting; they have never paid any dues to EMS.

Committees

◇ *Committee for Education*

V. Villani (Italy) is elected chairperson of the Committee for Education.

Review by G.-C. Rota

The Secretary will refute in public the inaccuracies of G.-C. Rota's review of the Paris Congress Proceedings. The review contains serious errors and misapprehensions.

NEW EDITORIAL TEAM

A new editorial team, based at Glasgow Caledonian University, is about to take over the responsibilities of the Southampton office. The Prague office will continue to operate as at present.

Material for future issues of the Newsletter should be sent to the new Editor or Advertising Officer, as indicated below. Material received at the Southampton office will, of course, be forwarded to our colleagues in Glasgow.

Editor

Professor R. Bradley
Department of Mathematics
Glasgow Caledonian University
City Campus
Cowcaddens Road
GLASGOW G4 0BA

Advertising Officer

Mr M. Speller
e-mail r.bradley@gcal.ac.uk : msp@gcal.ac.uk

The other members of the team are Professor J. Gomatam and Dr V. Jha.

EMS Council Meeting

The Council of EMS meets on 20–21 July, 1996, in Budapest, at the the Mathematical Research Institute of the Hungarian Academy of Sciences, district 5, Realtanoda utca 13-15, Lecture room, beginning 9.00 a.m.

The Agenda of the meeting has been mailed to delegates in April and futher material will be sent in early June.

Delegates who have not received the Agenda are kindly requested to contact the Secretariat (e-mail: makelainen@cc.helsinki.fi fax: +358-0-19123213).

EMS SUMMER SCHOOLS - CALL FOR PROPOSALS

The European Mathematical Society has launched its series of Summer Schools. The series is intended to include two schools a year, one in Pure Mathematics and one devoted to applications of Mathematics. With this activity the EMS wants to encourage young European mathematicians to meet and study together current developments in Mathematics and its applications.

The EMS, through its Summer School Committee, will examine proposals for summer schools fully organized by other institutions. To meet the EMS requirements, each school should be at a pre-doctoral level, last from 2 to 3 weeks, and have 100-120 participants, mainly graduate students or young mathematicians coming from several European countries. Costs of participation should be kept low and, if possible, grants should be available to people from countries which cannot afford any financial support. The EMS will guarantee its moral support to the selected schools, advertising within the European mathematical community and do its best to help the organisers to raise funds.

Topics, which may be single or composite, sites, and organisers of the schools will vary each year. The first two schools will take place

in 1996: one on Algebraic Geometry in Eger, Hungary, July 29 - August 9 (for the announcement see EMS Newsletter, March 1996, p.19, or <http://www.emis.de/newsletter/19>) and one on Analysis and Synthesis of Nonlinear Oscillatory Systems, Russian Academy of Sciences, July 1.

The Society is now asking for proposals for the two 1997 summer schools. A proposal should in particular contain the topic (title and short description), names of lecturers, site, timing, costs, conditions for participants, name and address of the organizer.

Proposals should be sent to:

Prof. G. Monegato
Dipartimento di Matematica
Politecnico di Torino
Corso Duca degli Abruzzi, 24
10129 Torino, Italia
Fax: 39-11-564.7599
Email: monegato@polito.it

if possible by June 30. Decision can be expected by the end of July.

Giovanni Monegato
Chairman
EMS Summer School Committee

Report on the Committee for Mathematics Education (CME)

This is the last report about CME which I deliver as the Chairman of this Committee. First of all, I take the opportunity to thank the other members of the CME for their support over the past four years. Secondly, I thank the editors of the Newsletter of EMS for their patience and their willingness to publish all the contributions which I forwarded to them. Soliciting contributions to the education section of the Newsletter, as before, was also in the past year the main activity of CME and its Chairperson. We rarely succeeded in motivating colleagues from the mathematical community as such to submit any kind of contributions. The gulf between mathematics and mathematics education appears to be as wide as ever. Those who are interested in educational issues apparently do not view it worthwhile to write about their experiences and to report their opinions. Most of the contributions in a way came from outside. Thus, my original intentions (see my programmatic statement in Newsletter no. 4) were destined to fail heavily. Despite that, I still hold it very necessary to have a forum like CME and the section in the Newsletter and I encourage any effort for enhancing an educational awareness in the mathematical community. This is based on the conviction that not only the future of mathematics education itself at all levels but possibly to some extent even the development of scientific maths will be strongly related to educational processes and movements. I think, that certain phenomena in the US foreshadow what we can expect for Europe as well. Without serious consideration of broad educational issues it will get more and more difficult to justify the high investments in mathematics at the universities, especially in concurrence with other related subjects as computer science.

In conclusion, I hope that CME will flourish and grow under the guidance of its new chairman Prof. Villani who I wish much success with this attractive task.

Willi Dörfler

ON THE FUTURE OF MATHEMATICAL PUBLICATIONS

NOT A CHARTER

Peter W. Michor

There is an ongoing discussion on the future of Mathematical Publications in the age of electronic communication, and many things are happening: electronic journals appear which are no longer printed, and preprint servers take over the role of timely information on new developments in science. Many scientific news spread via email, like in the heroic days of enlightenment, when personal letters were the main vehicles to communicate scientific discoveries.

For Mathematics a lot is at stake since it depends very much on the compiled literature, its reliability and accessibility. Mathematics is very vulnerable to any downgrading of the reliability of its literature which could be a companion of the more easy means of publishing today. But Mathematics is also happy to have a de facto standard of publication: TEX. I think that TEX will be stable in the future. In certain aspects the invention of TEX is like the invention of the alphabet. There is high value in its stability, so it will be stable. Even the development of the TEX dialects (Latex, AmSTeX) is slowing down considerably, not many users are migrating. Of course the raw TEX is not the means to distribute journals. Here the standard seems to be postscript now, and might be Adobe pdf later – so one must keep the chance to transform to changed standards later. I do not think that standards will change as rapidly in the future as they did in the past, since also here stability is of high value to the community. We might even have postscript many decades from now, if not forever.

The main vehicle for the publication of Mathematical research are the scientific journals; some of them have a tradition of more than a century. There is an established method of refereeing, deciding, and editing, and some fear that this is in danger. The real opponents of journals are the preprint servers. The hep-tp server is starting already to implement refereeing. The unbundled articles alone seem to be better units of scientific information transmission than issues of journals. See also the following information:

Hayes, John R.

The Internet's first victim? (academic publisher Reed Elsevier; electronic publishing infringes on

traditional publishing services) (Industry Trend or Event) Forbes v156, n14 (Dec 18, 1995):200 (2 pages).

Abstract:

London-based academic publishing house Reed Elsevier may be losing its profitable business to the powers of the Internet. Louisiana State University's library recently retracted a \$446,000 subscription of 1,569 scholarly journals from Reed Elsevier, opting instead for an Internet-based service that enables the library to generate a requested article within two days. Instead of paying out \$446,000, the library only needed to pay \$25,000 in copyright and delivery fees. Students and professors can now use the Internet to review over 17,000 academic journals' table of contents and order any of the articles therein. The university utilizes the services of the UnCover Co, an article retrieval company that offers journals' table of contents on the Internet and faxes along any requested articles for roughly \$13 each. Reed Elsevier is certain that the Internet will not completely overtake its businesses since professors still need their products. The flexibility and speed of electronic publishing could alter the landscape of traditional ink-on-paper publishing.

The decision reported in this article might not be unrelated to the court ruling against Exxon which was decided to be guilty of copyright violation since a scientist there copied articles from chemical journals although the journals were subscribed several times by the libraries of Exxon.

Mathematics is different. The literature is of high value, each paper is unique, results are rarely published several times. Journals as boards of editors and with established refereeing and publishing policies exist, are recognized, and will stay if they adapt. Old tradition nearly never die, they just become feeble if they do not serve any purpose. I think that journals could be the means of scientific publication also in the electronic age, at least in Mathematics. By adapting I mean that journals must be easily accessible and quicker in publishing, and they should be printed and distributed at lower cost. This is possible: have a look at the electronic library

of the European Mathematical Society (EMS) at <http://www.emis.de> and its (now: March 25, 1997) 10 mirrors and 17 journals. Also some commercial journals are in there. I think that for reasonably priced printed versions of electronically accessible journals there will always be a market: libraries, even private subscriptions of the special journal in one's own field.

About archiving: The electronic library of the EMS is a sort of model for this: mirror sites have to agree to keep the whole content of the server. In the future one could ask them also to keep an intact mirror of a not publicly accessible server containing all TeX-files and necessary programs to produce dvi-files. If there are several hundreds of these mirrors over the world, we have solved the problem of archiving in the best possible way.

There is always the argument about copyright, and about the interests of the commercial publishers which should be protected. On the other hand nearly nobody speaks for the interests of the main actors involved: authors and readers. Authors of scientific articles want their work widely distributed, easily accessible, and safely kept in the future. They do not earn money with most of their articles, only scientific reputation, and this is not provided by commercial publishers who severely restrict the circulation of journals by very high prices, it is only provided by the reputation of the editorial board and by the readership of a journal. Readers of scientific articles want quick information and easy access. One has the feeling that today more is written than read, so readers are very valuable, it should be easy for them to get at their reading. Who is speaking on behalf of authors and readers? It should be the learned societies. But the largest of them are indeed like publishing houses and they seem more interested in the wellbeing of their revenue-generating enterprises than in the interests of their members, the author and readers of mathematical articles.

The following charter would take care of the interests of authors and readers.

DRAFT OF A CHARTER OF FREE ELECTRONIC ACCESS TO PUBLICATIONS

Mathematical literature and access to it is the single most important asset of the world of mathematics. But there is stress to it: prices of journals are rising higher and higher, whereas budgets of libraries are

increasing rather below the rate of inflation or even decreasing. There are more and more new journals. Even in big libraries one cannot find all serious journals today. The role of a printed copy of a journal nowadays consists of sitting in a library waiting for an article out of it to be photocopied. A conservative estimate is that on the average an article is photocopied 50 times, all over the world, and read 25 times. To typeset, print, and distribute it is a waste of human and natural resources, the same service could be done via computer quicker and more widespread.

This charter is not meant to formulate the future of all the mathematical communication, its aim is only to pave a way for the transition of traditional journals to freely accessible electronic ones. The result might be cheaper and better accessible mathematical literature in the future.

The rationale behind this charta is the following. The aim is to try to lower the overall cost of mathematical literature. One way could be the following: One should distinguish carefully between the final electronic version of a paper, into which besides the work of writing and refereeing only marginal costs have been invested, and the printed and distributed version, which makes use of a somewhat industrial process. The costs of the former, since they are small, should be carried locally, by academic institutions or libraries. Important libraries could adopt existing journals and take over their costs up to the electronic product. Free personal access to the electronic product should be ensured. The costs of the latter industrial process should be borne by the consumer (library) who prefers to have at hand a nicely printed version. There will be not so few of them, perhaps.

DRAFT OF THE CHARTA

1. The right of access to the electronic file of a paper which was prepared electronically by the author or his institution lies with the author(s).
2. If the author submits this paper to a preprint server and/or if the paper went through a refereeing process positively, the author automatically acknowledges the right of free electronic access to this paper to the (mathematical) public.
3. If a journal prints a refereed article the right to distribute and sell this printed paper lies

completely with the publisher of the journal. But the right of free electronic access to the file remains at the public.

4. Everybody who uses the right of electronic access to a paper is entitled to print freely some copies of it for personal or restricted (educational) use. He is not entitled to sell copies of this paper at profit.
5. Libraries are entitled and asked to keep permanently accessible files of electronically accessible journals, in order to ensure their perpetuity, besides or without printed copies.

STATUS OF DISCUSSION

The draft above got very mixed responses. Among them: A short charter like this has its charm, but if we start making all the sentences really precise it will get as ugly as the declarations of the European Community. Some say that it is by far too early to fix any rules, or that it is really dangerous to do so: it might wake sleeping dogs.

The idea to have a charter like that has not found enough support by the influential persons thinking about the future of Mathematical Publications, especially in Europe. It seems better to drop the idea. On the other hand, things may be formed and influenced now, whereas habits will be fixed later, and the chance to lower the cost of mathematical literature as a whole may be over.

Thus the formulation of the charter is presented to the public in the form of this article. The reader should be aware that no assembly of any legitimation has voted on it - it is just the personal opinion and guideline of the author: but it did lead to the creation of the Electronic Library of the European Mathematical Society (<http://www.emis.de>).

(P. Michor is secretary of the EMS 1995-98 and chairman of its Committee on Electronic Publishing)

Letters to the Editor

The Editor welcomes letters on topics of general interest to all mathematicians. The following is a somewhat condensed version of such a letter, recently submitted by Dr L. Hethelyi, formerly at the Technical University, Budapest. The views expressed are, of course, those of the author, who also takes responsibility for the accuracy of the factual content.

Downsizing at the Hungarian Universities

In June of 1995, the Hungarian Parliament reduced the provision for salaries and social security payments in the university sector by between 15 and 18 percent, with effect from 1 September of that year, resulting in redundancy for 6,300 teaching staff (about a quarter of all teaching staff in Hungarian higher education), a reduction that had to be carried out in just a few weeks, in order to give statutory notice to those affected.

I believe, however, that these dismissals are illegal, since in all cases the budget amendment alone was given as the reason for dismissal. While this is clearly the factor dominating the general issue, it is not specific to any individual, and therefore in itself is not sufficient reason for the dismissal of any particular public servant. In my opinion, a breach of the Public Service Act has taken place.

Having asked the Ombudsman to investigate the process of dismissal at the Budapest Technical University, and to alert its Rector to the possibility that a violation of the law had taken place, I received a response that confirmed my views. I understand that the Ombudsman's office has reported his findings to the Minister of Education and Culture, who has responsibility for such legal matters. Newspaper and television coverage of the issue followed between December 1995 and January of this year. A letter from the Minister to the Rector, published in the University, supported the Ombudsman's position, suggesting that the appropriate authority to decide on individual cases was the Labour Court.

In fact, few of those affected followed this course, perhaps having little hope of success. This fact, however, was quoted by the Minister in support of his view that in most cases the downsizing had been carried out lawfully, despite the Deputy Ombudsman's comment, in a radio interview, that the Minister was willing to remedy the situation. (It is rumoured that there is a contingency plan, should the Labour Court find in favour of those who have applied to it, to reinstate all affected teaching staff, although no one knows where the necessary funding will come from.)

So far, two readers at Budapest University have won their cases, because no grounds for their dismissal had been given. Two others, whose cases involved questions of early retirement, were not successful. There remain to be decided those cases in which only the amended budget was cited, although one individual has been reinstated in an out-of-court settlement.

We eagerly await the independent Hungarian court's decisions.

L. Hethelyi

Problem Corner

Paul Jainta, Werkvolkstr. 10, D-91126 Schwabach, Germany

For reasons beyond our control this article has not been edited in the usual way.

Mathematics has outlasted communism**The Baltic Way**

After the fall of numerous Communist regime the West has reached a better starting position in every field except for a few special cases. By a strange quirk of history one of these exceptions has been mathematical education. Quite different from things in Eastern Europe the following graphic assessment describes the dull routine of mathematical everyday life in the West accurately. Here, a deep gulf yawns between those who teach in schools and those that do mathematical research. The result has been that gifted young mathematicians do not get enough encouragement in their studies. Their teachers get little exposure to new developments in mathematics, and both suffer from a lack of status in the society at large.

In Eastern Europe there seems to be much more interplay between those who teach mathematics, who coach students for exams (competitions and so on) and those who create it. Teaching itself is seen as a much more artistic activity than it is in the West, and some of the best mathematicians of the Eastern countries have spent much time and effort working with students at school. A rich culture of mathematical cooperation among all levels of instructing students has developed, including the participation of world-class mathematicians in extra-curricular programs, curriculum development, and teacher training. So, it is no accident that the *International Mathematical Olympiad* started as a contest among the Eastern bloc countries - and this contest was only the most illustrious of a dense and wide network of mathematical competition. Mathematical circles and summer camps were still another way in which teachers, students, and mathematicians formed close relationships.

Clearly, one strong influence on the development of these institutions in Eastern Europe was the nature of post-war communism. The Eastern bloc governments invested heavily in education. The prevalent ideology gave a central place to science and technology as crowning human achievements. Especially, mathematicians were lucky. Researchers of that kind with their pencils and notepads, were relatively free to work. It's hardly surprising that Mathematics came to be a common language for intellectual exercise. So was the extraordinary mathematical culture which developed in Eastern Europe a culmination of communism ? Or was it a silver lining, flourishing despite, or because of, the lack of academic freedom ? Historians will be working this out for decades to come.

Meanwhile, we must take care that we preserve what has grown up behind the Iron Curtain. Many of the institutions and practices unfolded there may not survive the transition to a market economy. The Russian journals *Kvant* and *Matematika v Shkole* are already having trouble. Rumour has it that they cannot get paper because publishers find it more lucrative to print detective novels. And mathematicians are leaving Eastern Europe, to earn a better living in the West. Once abroad, they often do not have the time to devote to work with pre-college Students. Capitalist mathematics puts a premium on publishing, not on teaching or working with students. The expertise that these people have in training young mathematical minds often goes to waste in the West. It is urgent that we support where we can the continuation of the mathematical culture of Eastern Europe. It is likewise important that West learn from East about how to nurture mathematical talents, how to value the work of teachers as well as the achievements of researchers, how to present mathematics to those who are not yet in the profession.

After all there is good reason to believe that Western and Eastern traditions are flowing into joint ventures in the field of promoting mathematically talented students from which both sides will make an increasing profit. In the *Problem Corner* we are giving priority to a propagation of joint mathematics problem solving competitions such as the *Tournament of the Towns* (on which I will report another time). As matters stand the co-production between East and West to give many capable students academic opportunity and the problem section will get something out of it too: an abundant supply of problems from Olympiad competitions from Eastern countries which are likely to be not well known.

Another outstanding mathematical joint product of that kind is *The Baltic Way*. Prof. **George Berzsenyi** of Rose-Hulman Institute of Technology, Department of Mathematics, Terre Haute, USA, a Hungarian by birth, and the heart of the *International Mathematical Talent Search*, has given it an encomium in *Consortium*, the quarterly newsletter of the *Consortium for Mathematics and its Applications*, seated in Lexington, MA.

The name of this competition commemorates the courage and determination of the people of Lithuania, Latvia, and Estonia in August of 1989, when over a million of them stood hand in hand along the roads connecting their capitols, Vilnius, Riga, and Tallinn, in a peaceful demonstration for their freedom from the Soviet Union. This culmination of their unified struggle for independence became known as „The Baltic Way“, and thus for the three small Baltic republics marked the first step towards renouncing from the *Big Brother* Russia. Hence it was most appropriate to name the friendly mathematical competition among teams of secondary school students in these republics „The Baltic Way“. Naturally, Mathematical competitions have a long tradition in Lithuania, Latvia, and Estonia, too. Their pioneering in team competitions stems from the fact that for the nationwide individual contests a lot of preparatory work is done at the school level, where the students work in groups with the guidance of their teachers. This observation led the Lithuanians to start a team competition in the fall of 1986, with each team consisting of five students, who work together to produce a solution to each of the 20 problems posed. They are allowed four hours to compete their work - hence the level of some of the problems can fairly be high.

By 1989, there were already over 20 Lithuanian teams in the competition. In that year, they were joined by visiting teams from Estonia and Latvia, whose leaders and members also found the competition to their liking. Consequently, in 1990 „The Baltic Way“ was initiated, in which each country was represented by its winning team. Since then, the competition was hosted by each of the three countries at least once. Both Prof. **Agnis Andžans** (of Latvia) and Prof. **Algirdas Zabulionis** (of Lithuania) have played a tremendous part in establishing this exceptional contest. Due to their indefatigable efforts „The Baltic Way“ has described a path of success, and therefore could have been expanded to other countries of the Baltic Sea region as well. Thus, in „Baltic Way - 1993“, in addition to the three Baltic republics, teams from Poland, Denmark, Finland, Sweden, and Iceland also competed. One can rightly say, there seems to be a propitious future for „The Baltic Way“.

Now let us dip into the bag of tricks of North/East European creators of mathematical posers. As a problem set this issue, I give some problems proposed for *The Baltic Way* 1995, held in Västerås, Sweden, 10-14 November. (The name of the country/town in brackets denotes the origin of the problem, respectively).

Q 45. Prove the identity: $\sin^3 18^\circ + \sin^2 18^\circ = \frac{1}{8}$ (Estonia).

Q 46. A regular tetrahedron has edges of unit length. Denote by S the intersection of the six balls having the edges of the tetrahedron as diameters. Show that the volume of S is at least $\frac{1}{54\sqrt{2}}$ (Finland).

Q 47. In a penalty shoot-out in soccer each side gets five penalties. The teams take their penalties in alternation. As soon as one side has secured victory no more penalties are taken. How many different score sequences are possible in a penalty shoot-out ? (Iceland).

Q 48. Prove that for positive a,b,c and d the following inequality is valid:

$$\frac{a+c}{a+b} + \frac{b+d}{b+c} + \frac{c+a}{c+d} + \frac{d+b}{d+a} \geq 4 \quad (\text{Latvia}).$$

Q 49. Prove that $\frac{1995}{2} - \frac{1994}{3} + \frac{1993}{4} - \dots - \frac{2}{1995} + \frac{1}{1996} = \frac{1}{999} + \frac{3}{1000} + \dots + \frac{1995}{1996}$ (Poland).

Q 50. Let O be the center of the inscribed circle of a triangle ABC.

Show that $|AB|^2 \cdot |OC|^2 + |BC|^2 \cdot |OA|^2 > |AC|^2 \cdot |OB|^2$ (St Peterburg)

SOLUTIONS

Once again I am able to offer a medley of solutions to previous problems. We start off with **Dr Z Reut**, London, who has dealt with question 34, appearing in the Newsletter No 18.

Q34. The diagram shows the view from above a folding door. Point O is fixed: it is the point where the door is connected with the wall. Points I and J move along the rail OX. The distances OA, AI, IB, BJ and JC are equal and remain constant as the door moves. Clearly I and J are always the midpoints of lines AB and BC.

Take OA=4cm and construct on the same diagram the paths taken by A, B and C as the door takes up all possible positions.

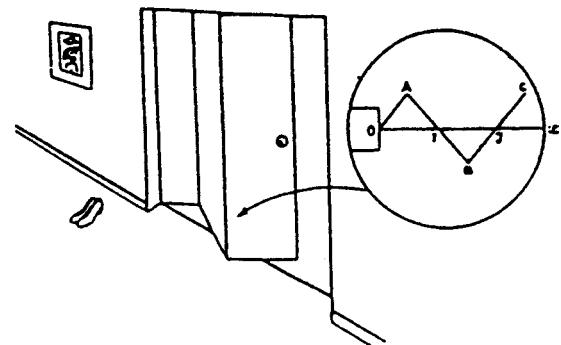

Solution:

Let us take the axis OX along the rail and OY perpendicular to it. Since the distance OA = a remains constant the coordinates of point A satisfy the equation $X_A^2 + Y_A^2 = a^2$; the path is an arc of circle with radius a and centre at O. Since the distances OA = AI = IB = BJ = JC all equal to a, the triangles OAI and IBJ are equilateral. The co-

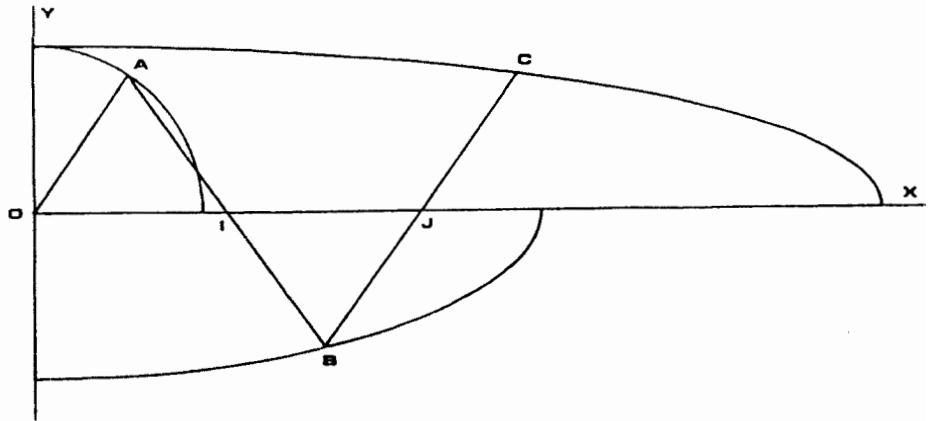

ordinates of point B in terms of those of point A are given by $X_B = 3X_A$, $Y_B = -Y_A$; they satisfy the equation $\frac{X_B^2}{9} + Y_B^2 = a^2$; the path is an arc of ellipse with axes (3a,a) and centre at O. The coordinates of point C are given by $X_C = 5X_A$, $Y_C = Y_A$; they satisfy the equation $\frac{X_C^2}{25} + Y_C^2 = a^2$; the path is an arc of ellipse with axes (5a,a) and centre at o. The diagram is for a = 4 cm and the angle AOI equals to 55°

Also solved by Brian R. Stonebridge, Department of Computer Science, Bristol.

- Q35. Designed to be a comfortable seat this corner bench changes easily into a bed 140 cm by 190cm (height 18cm). To do so you fit together the two blocks of foam rubber that makes up the sofa.

As a design feature the curve CD is made up of 2 arcs of circles. The tangent to the curve at C is perpendicular to side BC. Construct a plan view of the two parts of the sofa fitting together to form a rectangle. Use a scale of 1:10. Show all your construction lines.

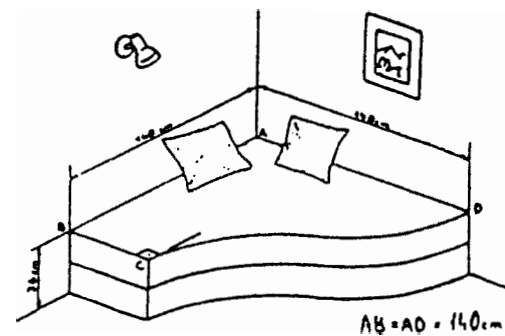

Solution: (Dr Z Reut, London)

The upper part is rotated in horizontal plane and positioned to form a rectangular sofa. The side $BC = 190 \text{ cm} - 140 \text{ cm} = 50 \text{ cm}$. Let us draw rectangle $ABA'B'$ with sides $AB = B'A' = 140 \text{ cm}$ and $AB' = BA' = 190 \text{ cm}$; the segments $BC = B'D$ both measure 50 cm . Join points C and D by a straight line, and find the midpoint of CD ; then find midpoint of each half, and draw perpendiculars from each midpoint to intersection with sides AB' and BA' to find centres of circles for two arcs from points C and D to join at the midpoint of CD .

Also solved by Brian R. Stonebridge.

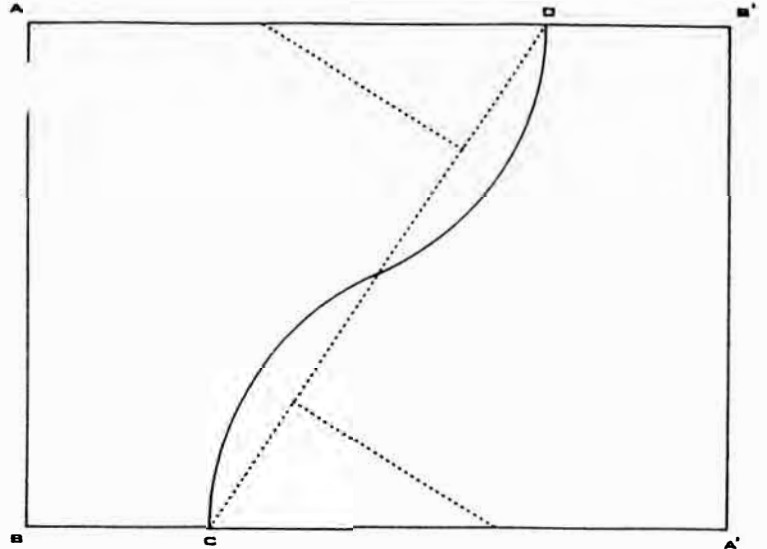

- Q36. In the cellar Pitt has set up the room which is 7m long with an interesting lighting system. He has installed two moveable spotlights which send out a conical beam with an apex angle of 90° (see the diagram).

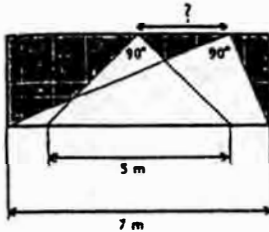

The first spot, placed right in the centre of the room's ceiling, is set up in a way that lights up the floor in a circle 5m in diameter. Calculate the exact distance between the spots.

Solution (Brian R. Stonebridge, Bristol)

In the diagram, the right angles at X and Y are the angles in semicircles on the diameters, AB , CD , which must have radii 2.5 and 3.5 respectively.

Pythagoras theorem in ΔOXY gives

$$XY = \sqrt{3.5^2 - 2.5^2} = \sqrt{6}.$$

Also solved by Maurice Brémond, Avignon, France

- Q 37.

Madam Yolande is at the hairdresser. When she sits down in the chair it is exactly 14.00 (2.00 pm) on her watch and she sees in the mirror in front of her the reflection of the salon clock. It shows 6.40 as depicted in the picture. The assistant has just changed the battery but has not reset the correct time.



At the end of her appointment just as she leaves her chair Mme Yolande notices with amazement that the hands of her watch and those of the reflection of the clock are in exactly the same position.

What time must it be given that the clock and the watch are working perfectly?

Solution. (Brian R. Stonebridge)

The clock which Madame Yolande sees in the mirror behaves precisely like a clock (without markings) running *backwards* starting at $5 \times 60 + 20 = 320$ mins „before“ midday. Let her appointment take x mins. The hands of watch and reflection coincide when $320 - x = 120 + x$, thus $x = 100$, the appointment lasted 100 minutes and the time at the end of the appointment is 15.40 (3.40 pm).

Q38. (François Sigrist, Institut de Mathématiques, L'Université de Neuchatel, Suisse)

Five spherical caps of the same radius are disjoint on a sphere. Prove that one can move them so as to make space for a sixth one.

Solution (Brian R Stonebridge)

A cap is defined by a circle on the sphere and a cone can be generated by rays from the centre of the sphere, through the circle, which is the edge of the cap.

We take the angle α to be the latitude of the top cap, as shown in the diagram.

If $\alpha = \frac{\pi}{4}$, six cones can be placed along rectilinear axes through O, and the planes which define the cones form a cube with faces containing the disks, which touch. The sections of the cones made by the coordinate planes show that $\alpha = \frac{\pi}{4}$ is the limiting case and no further increase in α is possible, with this configuration, if the caps are to remain disjoint.

If $\alpha < \frac{\pi}{4}$, six cones can be placed inside the six described and there will still be room to move them.

However, if $\alpha > \frac{\pi}{4}$, place one cap symmetrically at P, say. It is impossible for four caps to be placed touching it, since the largest angle for four cones would occur if their axes were equatorial to the sphere, and the total equatorial angle would be $4 \times 2\alpha > 2\pi$. But for *five* to be placed, one must be at the base and hence three must touch the top cap (unless there is room to spare). This means that the base cap is defined by the vertical sections POR, POQ, ... which show that it must have an angle, $\beta = \pi - 3\alpha < \frac{\pi}{4}$, since $\alpha > \frac{\pi}{4}$. This contradicts the condition that the caps have the same radius.

Thus, if five spherical caps of the same radius are disjoint on a sphere, we have proved that $\alpha \leq \frac{\pi}{4}$, and that this condition is sufficient to allow one to move them so as to make space for a sixth one.

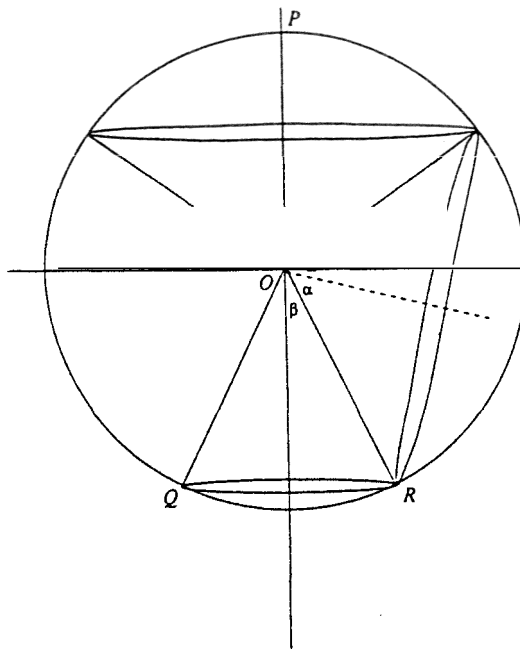

Diagram showing the top cone, an adjacent cone and the base cone.

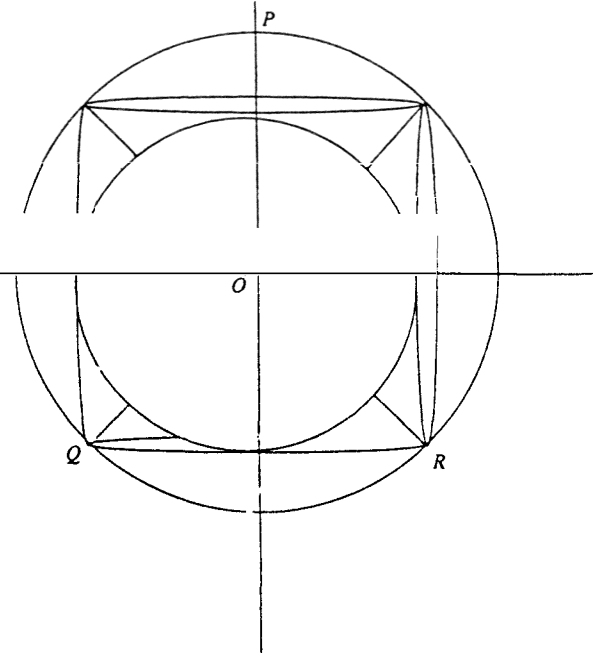

Diagram showing the arrangement of six cones when $\alpha = \pi/4$.

The solver finally notes that provided the caps describe equal circles on the sphere, they need not have the same radii, and these might not be the same as the radius of the sphere. The proof depends upon the circles of intersection (which would remain unchanged) and not upon the shapes of the caps.

We finish this number of the Corner with two rough solutions to past problems. The author, *Maurice Brémond, Avignon*, used an argument each differing from the then featured solution. Both problems appeared in Newsletter No. 17, September 1995, pages 22/23.

Solution to Q 28. D'après le théorème d'*Al Kaschi* (!): $D = \sqrt{1^2 + 2^2 - 2 \cdot 1 \cdot 2 \cdot \left(-\frac{1}{2}\right)} = \sqrt{7}$.

Solution to Q 32. Cette variante n'est en fait qu'une explicitation de la solution donnée à la page 27:

$$n = \sum_{p=0}^{1990} 10^p = \frac{10^{1991} - 1}{9} = \frac{10^{11} - 1}{9} \times \frac{(10^{11})^{181} - 1}{10^{11} - 1}$$

n'est donc pas un nombre premier, en vertu de l'identité $\forall (a,b,p) \in \mathbb{R} \times (\mathbb{R} \setminus \{a\}) \times \mathbb{N}^*$, $\frac{a^p - b^p}{a - b} = \sum_{i+j=p-1} a^i b^j \in \mathbb{N}$ si $(a,b) \in \mathbb{N}^2$.

That completes the material I have available for this number. The Olympiad Season is booming. Please collect your contests and send them to me. Also send me your nice solutions to problems posed in the *Corner*.

Finally, propose problems for which readers will send in solutions. Proposals should, whenever possible, be accompanied by a solution, references, and other insights which are likely to be of help for the editor. They can be anything from elementary to advanced, from easy to difficult. Original problems are particularly sought. So, please submit any interesting problems you came across, especially those from (problem) books and contests that are not easily accessible. But other interesting problems may also be acceptable provided they are not too well known and references are given as to their provenance. I hereby invite my readers to share them with their colleagues and students.

I welcome your input, and especially problem sets and solutions for use !

EURONEWS COUNTRY BY COUNTRY

BELGIUM

Fourth Week on Algebra and Algebraic Geometry

Semana de Algebra y Geometria Algebraica 4 (SAGA4)

Date: 12-17 September 1996

The conference will take place on September 12 and 13 at the University of Antwerp, and on September 16 and 17 at the University of Brussels. Hotel rooms will be available in Antwerp.

Program: Invited speakers will deliver one-hour lectures on current and future trends in their research fields. Besides, a number of sessions for the presentation of 30 minute talks are planned. Topics of the conference include Lie algebras, Hopf algebras and quantum groups, representation theory, noncommutative algebraic geometry and algebraic K-theory.

Main lecturers: (tentative list): M.Ojanguren (Lausanne), J. Alev (Reims), R.Camps (Barcelona), A.Facchini (Udine), A.Bak (Bielefeld), A.Narvaez (Barcelona), B.Pareigis (Muenchen), G.Elencwajg (Nice).

Organizing committee: S.Caenepeel (Brussels), A.Verschoren (Antwerp), A.Bak (Bielefeld), P.Ara (Barcelona), M.V.Reyes-Sanchez (La Laguna)

Publication: The conference proceedings will be published as a separate volume of the Bulletin of the Belgian Mathematical Society. Submissions should be sent before February 1997 to one of the local organizers.

Registration: The registration fee for the conference will be 1000 BEF (about 35 USD).

Local organizers: S. Caenepeel, Faculty of Applied Sciences, Free University of Brussels (VUB), Pleinlaan 2, B-1050 Brussels

A. Verschoren, Department of Mathematics, University of Antwerp (RUCA), Groenenborgerlaan 171, B-2020 Antwerp

Information: E-mail saga@maze.ruca.ua.ac.be

ITALY

Program of C.I.R.M. (Trento) for the year 1996

The Centro Internazionale per la Ricerca Matematica (C.I.R.M.) of Trento will organize during the year 1996 the following Conferences:

1. "Low Dimensional Topology", from July 1 to July 6, at the Grand Hotel Bellavista in Levico Terme (Trento).

Scientific Organizers: M. Boileau (Toulouse), D. Gabai (Pasadena), A. Tognoli (Trento).

This meeting follows the conference on "Poincaré Conjecture", held in Levico from July 3 to 14, 1995 and a part of the proof's project by V. Poenaru (Orsay) will be expounded and discussed.

Deadline for applications: May 31, 1996.

2. School-Conference "Trends in Algebraic Geometry, Applications and Relations with Physics", from September 3 to September 13, at the Grand Hotel Bellavista in Levico Terme (Trento).

Scientific Organizers: M. Andreatta (Trento), E. Ballico (Trento) and G. Bolondi (Sassari).

The C.I.R.M. and the Department of Mathematics of the University of Trento with the support of Europroj and G.N.S.A.G.A. are sponsoring a school (Sept. 4-8) followed by a conference (Sept. 9-13).

Main lecturers of the school will be: V. Alexeev (Athens, USA) and C. Simpson (Toulouse)-C. Walters (Nice).

Provisional list of speakers during the conference: C. Bartocci (Genova), A. Beauville (Paris), M. Beltrametti (Genova), U. Bruzzo (Trieste), F. Campana (Nancy I), F. Catanese (Pisa), L. Chiantini (Siena), A. Collino (Torino), A. Conte (Torino), B. Dubrovin (Trieste), Y. Kawamata (Tokyo), Yu.I. Manin (Bonn), T. Peternell (Bayreuth), P. Pirola (Torino), R. Salvati Manni (Roma I), J. Wisniewski (Warsaw), Q. Zhang (Columbia, USA).

Deadline for applications: May 31, 1996.

3. "Computational Methods for Oceanic and Atmospheric Flows", from September 29 to October 4, 1996, at the IRST in Povo (Trento).

Scientific Organizers: V. Casulli (Trento) and A.F.D. Loula (Rio de Janeiro).

Provisional list of lecturers: D. Ambrosi (CRS4, Cagliari), R.T. Cheng (USGS, Menlo Park), J. Douglas, Jr. (Purdue University), D. Eppel (GKSS Forschungszentrum, Geesthacht), H. Kapitza (GKSS Forschungszentrum, Geesthacht), G. Lang (Bundesanstalt für Wasserbau Aussenstelle Kueste, Hamburg), A. Loula (LNCC-CNPq, Rio de Janeiro), D. Marchesin (IMPA-CNPq, Rio de Janeiro), P.Y. Sheng (University of Florida, Gainesville), P.L. Silva Dias (University of Sao Paulo), A. Staniforth (Recherche en Prevision Numerique, Dorval), G. Stelling (Delft Hydraulics), T. Toro (University of Manchester), R.A. Walters (USGS-WRD, Tacoma).

Deadline for applications: June 30, 1996.

4. "Stochastic Partial Differential Equations and Applications", from January 6 to January 11, 1997, at the Grand Hotel Bellavista in Levico Terme (Trento).

Scientific Organizers: G. Da Prato (Pisa) and L. Tubaro (Trento).

Provisional list of lecturers: P. Baxendale (Los Angeles), D. Blount (Tempe), E. Bolthausen (Zürich), A. Chojnowska-Michalik (Lodz), P.-L. Chow (Detroit), H. Crauel (Saarbrücken), M. Dozzi (Nancy), F. Fagnola (Genova), F. Flandoli (Pisa), P. Florchinger (Metz), M. Freidlin (College Park), M. Fuhrman (Milano), D. Gatarek (Sydney), B. Goldys (Sydney), L.G. Gorostiza (Mexico), I. Gyöngy (Edinburgh), R.Z. Khas'minskii (Detroit), N.V. Krylov (Minneapolis), H. Kunita (Fukuoka), H.-H. Kuo (Baton Rouge), I.A. Ibragimov (St. Petersburg), G. Jona-Lasinio (Roma I), R. Manthey (Jena), B. Maslowski (Prague), S. Meleard (Paris VI), J.L. Menaldi (Detroit), S.A. Molchanov (Charlotte), C. Muller (Rochester), S. Peszat (Hull), E. Presutti (Roma II), M. Röckner (Bielefeld), F. Russo (Paris XIII), M. Sanz (Barcelona), J. Seidler (Prague), R. Sowers (Urbana), A.-S. Sznitman (Zürich), O. Zeitouni (Haifa).

Deadline for applications: October 31, 1996.

For further information and applications please contact:

Mr. A. Micheletti - Secretary of CIRM. Centro Internazionale per la Ricerca Matematica
Istituto Trentino di Cultura, 38050 Povo (Trento), ITALY.

Tel.: +39-461-881628 - Telefax: +39-461-810629 - e-mail: michelet@science.unitn.it.

NORWAY

First Announcement
6-th Workshop on Stochastic Analysis
 (Oslo-Silivri)

Date: July 29 – August 4, 1996

Location: Vestlia Hoyfjellshotell, Geilo, Norway.

Main Lectures:

Professor Etienne Pardoux (Marseille) "Backward Stochastic Differential Equations, and Applications to Quasi-linear PDEs"

Professor Salah Mohammed (Carbondale, Illinois) "Stochastic Differential Systems with Memory: Theory, Examples and Applications"

Organizing Committee: L. Decreusefond, A.S. Ustunel (Paris), B. Oksendal (Oslo).

Sponsored by VISTA, a research cooperation between the Norwegian Academy of Science and Letters and Den norske stats oljeselskap a.s. (Statoil)

Program: The Sixth Workshop on Stochastic Analysis will take place in Geilo, Norway in the week July 29 - August 4, 1996. In addition to the sequences of main lectures by Pardoux and Mohammed the program will consist of shorter talks by the participants of the workshop.

Location: The registration and all lectures of the workshop will take place at Vestlia Hoyfjellshotell at Geilo, one of Northern Europe's most popular mountain resorts. Geilo, called the Gateway to the Mountains, is surrounded by a beautiful countryside, rich wildlife and magnificent sceneries. In addition it is close to glaciers and to the magnificent fjords of the west coast of Norway. Geilo is about 250 km northwest of Oslo and can be reached by bus, train or airplane (to the local airport).

Accommodation: All the participants will be lodged at Vestlia Hotel, for the special price of NOK 520 per day per person in a single room and NOK 460 per person per day in a double room. The price includes all meals and free access to the swimming pool, sauna, fitness room, tennis court and other facilities of the hotel.

Further Information: Updated information is available on the WEB at <http://www.enst.fr/~decrease/oslo.html>

A second announcement with more details will be sent out in May.

For more information please contact either
 A.S. Ustunel, E.N.S.T., Dept. Reseaux
 46, rue Barrault, 75634 Paris Cedex 13
 FRANCE

Tel. (33) 1-45 81 72 67,
 Fax: 33-1-45 89 16 64,
 email: ustunel@res.enst.fr

or

B. Oksendal, Dept of Mathematics
 University of Oslo, Box 1053 Blindern
 N-0316 Oslo, NORWAY

Tel. (47) 22 85 59 13,
 Fax: (47) 22 85 43 49,
 email: oksendal@math.uio.no

or

L. Decreusefond, E.N.S.T., Dept. Reseaux
 46, rue Barrault, 75634 Paris Cedex 13
 FRANCE

Tel. (33) 1-45 81 75 01,
 Fax: 33-1-45 89 16 64,
 email: decrease@res.enst.fr

UNITED KINGDOM

Europroj 96

Date: 11-16 September 1996

Location: University of Liverpool

Sponsors: European Union, London Mathematical Society

Programme: Europroj 96 aims to present some of the best recent work in algebraic geometry. Young researchers (both postdoctoral and postgraduate) are particularly welcome and funds are available to support a substantial number.

Programme Committee: S. K. Donaldson (Oxford)(chair), W. Barth (Erlangen), I. Dolgachev (Michigan), M. S. Narasimhan (ICTP)

Invited speakers: L. Caporaso (Harvard), A. Corti (Chicago), L. Goettsche (Pisa), C. Peskine (Paris), Z. Ran (Durham), G. Tian (MIT)

Deadlines: 15 April (abstracts), 1 June (financial support), 31 July (registration)

Information: su03@liv.ac.uk

Dr. P. E. Newstead (EP96)
 Department of Mathematical Sciences
 The University of Liverpool
 PO Box 147, Liverpool, L69 3BX, UK

Tel: (direct line) 0151 794 4040
 (International +44 151 794 4040)
 Fax: 0151 794 4061

E-mail: newstead@liverpool.ac.uk

UNITED KINGDOM

UNIVERSITY OF CAMBRIDGE

Isaac Newton Institute for Mathematical Sciences

The Institute began its scientific work in July 1992 with its first two programmes, on **Low-dimensional Topology and Quantum Field Theory** and **Dynamo Theory**; since then, twelve further programmes on **L-functions and Arithmetic**, **Epidemic Models**, **Computer Vision**, **Random Spatial Processes**, **Geometry and Gravity**, **Cellular Automata**, **Aggregation and Growth**, **Topological Defects**, **Symplectic Geometry**, **Exponential Asymptotics**, **Financial Mathematics**, **From Finite to Infinite Dimensional Dynamical Systems** and **Semantics of Computation** have been completed. On the advice of the Scientific Steering Committee, eight programmes have now been confirmed for 1996-97. Programmes that have been confirmed for the next two years are:

Dynamics of Complex Fluids

Organisers: TCB McLeish (Leeds), JRA Pearson (Schlumberger Cambridge Research), K Walters (Aberystwyth)

January to June 1996

Many fluids of industrial, biological and environmental importance (e.g. molten plastics, salad dressings, whole blood, sinovial fluid, fluidised sediments) respond in a complicated fashion when deformed. The reasons for this complexity can be traced back to their molecular structure and to the hydrodynamic forces acting between molecules. The programme will bring together experts who seek to relate flow behaviour to structure and those who seek to predict flow fields of such fluids in complex geometries, with particular reference to polymer melts, polymer solutions, liquid crystals and colloidal suspensions. This involves modelling on a wide range of length (and associated time) scales, i.e. from molecular dynamics to large scale continuum mechanics. Most of the mathematical problems that arise involve non-linear differential, integro-differential or integral equations; a full range of analytical and numerical techniques has to be employed to obtain solutions.

Computer Security, Cryptology and Coding Theory

Organisers: RJ Anderson (Cambridge), PG Farrell (Manchester), P Landrock (Århus), RM Needham (Cambridge)

January to June 1996

Over the past twenty years, the quest for dependable computer systems has fuelled rapid advances in cryptology and coding theory. Cryptology is used to secure electronic transactions, while coding theory has facilitated many recent advances in radio based communications. These techniques are central to designing distributed systems which will perform reliably despite the presence of noise and of malicious attacks, and there is a growing interaction between them at the theoretical level. Practical aspects are also important, and incorporating cryptographic and coding techniques into systems turns out to be much more complex than was first anticipated; this has led to interest in formal methods of verification and in robustness principles. By bringing together mathematicians, computer scientists and engineers working in these related fields, the programme aims to further both the theoretical and the engineering aspects of the art.

Mathematics of Atmosphere and Ocean Dynamics

Organisers: JCR Hunt (UK Met. Office), ME McIntyre (Cambridge), I Roulstone (UK Met. Office), J Norbury (Oxford)

July to December 1996

Weather forecasts are routinely computed for up to 10 days ahead, based on large quantities of wind, temperature and humidity data that are collected continuously and used to modify the computations. The data are of course insufficient to determine the exact state of the atmosphere. Since they are very expensive to obtain there is a premium on their optimal exploitation. Therefore it is of the highest importance for numerical weather prediction to identify the dominant processes and flow features that determine how the large scale weather patterns develop. By then ensuring that the continuous assimilation of data is consistent with these features the accuracy of the forecasts is greatly increased. Ocean modelling is beginning to develop similar data assimilation techniques. Recent exchanges of ideas between mathematicians and atmosphere-ocean dynamicists has brought a new geometric global viewpoint to these problems, in particular a new appreciation of how fluid-dynamical conservation laws, for example potential vorticity, connect with the symplectic geometric structure of the underlying equations of motion. A major challenge for the programme will be to bring ideas from geometry, analysis and the theory of dynamical systems to bear on the practical and urgent problems of weather forecasting, ocean and climate modelling.

Mathematical Modelling of Plankton Population Dynamics

Organisers: J Brindley (Leeds), M Fasham (Southampton), J McGlade (Warwick)

29 July to 6 September 1996

Plankton play a key role in ocean-atmosphere dynamics. Their effects range from alterations on a local scale of the structure of the sea-surface temperature and mixed layer depth, to ocean basin-wide emissions of potentially important climatological gases such as dimethyl sulphate, up to global fluxes of atmospheric carbon. These effects occur over a wide range of spatio-temporal scales and via a number of different biophysical processes.

Please turn over

The programme will bring together mathematical and numerical modellers with biological oceanographers to review, improve and develop models, addressing particularly the needs to understand the spatio-temporal scale distribution of plankton behaviour and its relationship with the physical dynamics of the ocean-atmosphere system.

Within the six week programme will be embedded a specialist meeting attended by much larger number than the core participants, focussing on the effects of physical forcing on plankton populations and the consequences for fisheries.

Four-dimensional Geometry and Quantum Field Theory

Organisers: Sir Michael Atiyah, H Osborn (Cambridge)

4 November to 13 December 1996

This six-week programme will focus on the exciting recent developments centering around a remarkable duality in four-dimensional space-time. This formally interchanges Electricity and Magnetism and works in certain non-abelian gauge theories. It has major implications for the understanding of strong interactions in physics and in four-dimensional geometry.

Representation Theory of Algebraic Groups and Related Finite Groups

Organisers: M Broué (Paris), RW Carter (Warwick), J Saxl (Cambridge)

January to June 1997

There is a famous theory due to Hermann Weyl for the characters of the finite dimensional irreducible representations of simple algebraic groups over the complex numbers. In finite characteristic no analogous formula has been proved, but there is a conjecture due to Lusztig which expresses the irreducible characters as linear combinations of the Weyl characters. This is related to certain characters of affine Kac-Moody algebras, and also to the representations of certain quantum groups - the latter being at the moment a rapidly developing branch of mathematics. Other related themes include subgroup structures of the corresponding groups of Lie type.

Non-Perturbative Aspects of Quantum Field Theory

Organisers: D I Olive (Swansea), P Van Baal (Leiden), P West (King's College, London)

January to June 1997

Recent results of Sen, Seiberg and Witten have made increasingly plausible the idea of a quantum transformation between the weak and strong coupling regimes of certain spontaneously broken supersymmetric gauge theories in space-time of four dimensions. The relevant ideas encompass and unify many topics studied intensively over recent years by particle physicists including QCD and the theory of instantons, solitons and their quantisation, conformal field theory, Yang-Baxter equations, the s and t duality of string theory and the mirror symmetry of Calabi-Yau manifolds. The new results have also already had an impact on pure mathematics, for example in the understanding of the Donaldson classification of four manifolds. The aim of the programme is to explore the idea of electromagnetic duality, to gain new insights into fundamental physics (for example, the issue of confinement in QCD, and the improved formulation of unified string theories), and into pure mathematics.

Disordered Systems and Quantum Chaos

Organisers: J Keating (Bristol), DE Khmelnitskii (Cambridge), IV Lerner (Birmingham)

July to December 1997

The quantum properties of disordered systems have been the focus of considerable attention in many branches of physics, principally nuclear physics and condensed matter physics. Recently it has been recognised that many of the same phenomena also occur in deterministic systems which possess only a few degrees of freedom, but which are chaotic in the classical limit. Even more surprisingly, the theories developed in these areas also have natural counterparts in a number of topics in mathematics; for example, in the study of spectral properties of random operators and random matrices, in the theory of Fourier integral operators, in harmonic analysis (specifically in the theory of the Riemann zeta-function and related L -functions). In the past few years an extremely stimulating and productive cross-fertilisation between the above fields has slowly been developing. The aim of the programme is to accelerate the already significant rate of progress on some of the important common problems which occur, in different guises, in each area. The main topics upon which the programme will focus are localisation, fluctuation statistics, and trace formulae; with a particular emphasis on their role in the theory of mesoscopic systems.

Neural Networks and Machine Learning

Organisers: C Bishop (Aston), L Valiant (Harvard)

July to December 1997

Programme details to be announced

For further information, contact the Executive Director, Isaac Newton Institute for Mathematical Sciences, 20 Clarkson Road, Cambridge CB3 0EH, UK; tel. 01223 335999; e-mail i.newton@newton.cam.ac.uk

GERMANY

Due to a typographical error please note the following amendments:

1. *The important deadline of 20 May 1996*
2. *The e-mail address should be* passow@mathematik.th-darmstadt.de

CALL FOR PAPERS

“Modern Mathematical Methods in Diffraction Theory and its Applications in Engineering”

Location: To be held in Freudenstadt/Black Forest

Date: 30 September – 4 October 1996

In 1896 Arnold Sommerfeld published his famous paper “Zür Theorie der Diffraktion” in vol. 47 of the “Mathematische Annalen”. A long series of studies on general mixed boundary value problems sprang up then. Boundary integral equations together with the Wiener – Hopf method have been generalized and are now a basis for analytical and numerical studies by many mathematicians and engineers working on wave diffraction problems.

The aim of this workshop is to join the experts, commemorating the centenary of Arnold Sommerfeld’s paper, with young researchers from mathematics and engineering to present their new analytical results in short communications or on posters. The conference subjects are:

1. Modelling of direct and inverse diffraction problems.
2. Analytical methods in diffraction theory.
3. Approximation methods and numerical algorithms.
4. Application to engineering problems.

Organizer: Department of Mathematics (Technical University Darmstadt)

Scientific Committee: H.D. Alber (TH Darmstadt), A. Boettcher (TU Chemnitz), N. Latz (TU Berlin), E. Lueneburg (DFVLR Oberpfaffenhofen), E. Meister (TH Darmstadt).

It is planned to have lecture and poster presentations. Participants wishing to present a paper at the conference are asked to submit:

1. A photoready abstract for including into the program **not more than 20 lines** (including title and authors) if possible send this one additionally by e-mail to the organizing committee.
2. An extended abstract **more than 3 pages** (DIN/A4) for selection by the scientific committee.

Both abstracts must be written in **English** and received by organizing committee not later than

20 May 1996 (extended deadline)

Organizing Committee: Prof. Dr. Erhard Meister, Ursula Roeder (secretary), Dipl. Math. Alexander Passow.

e-mail: passow@mathematik.th-darmstadt.de

O. C. address: Technische Hochschule Darmstadt, Fachbereich Mathematik, Arbeitsgruppe 12, Schlossgartenstrasse 7, 64289 Darmstadt, **Germany**

BRIEF REVIEWS

Edited by Ivan Netuka and Vladimír Souček. Books submitted for review should be sent to the following address: Ivan Netuka, MÚUK, Sokolovská 83, 186 00 Praha 8, Czech Republic.

E.Zeidler: Applied Functional Analysis. Main Principles and Their Applications, Applied Mathematical Sciences 109, Springer-Verlag, New York, 1995, xvi+404 pp., 37 fig., DM 98.00, ISBN 0-387-94422-2

The book is based, as the author says, on the application oriented method of teaching mathematics. This approach starts out from the question "What are the most important applications?" and then tries to answer this question as quickly as possible. The Hahn-Banach theorem is applied to separation of convex sets, to the moment problem, the minimum norm problem on the dual space, to the Čebyšev approximation and to the optimal control of rockets. Variational principles are explained and a motivation for weak convergence is given. Applications to the calculus of variations and to nonlinear eigenvalue problems are presented. Reflexive Banach spaces are studied and applied to convex minimum problems and variational inequalities, to obstacle problems in elasticity, to game theory etc. Further interesting topics treated include the mountain pass theorem, the Galerkin method and monotone operators, symmetric and conservation laws, basic ideas of gauge field theory, elementary particles etc. The Banach - Steinhaus theorem is applied to cubature formulas, the closed graph theorem to factor spaces, to direct sums and projections. Operator equations are studied in detail, in particular those with Fredholm operators. A series of applications to differential and integral equations is also discussed. Much very rich material is included in extensive problems sections attached to each chapter. This is a remarkable book (as is another book by the same author published as vol. 108 of the same series with the subtitle Applications to Mathematical Physics) which will be greatly appreciated by students as well as teachers. Strongly recommended to anybody who likes to learn or to teach nice mathematics. (in)

V.Chari, A.Pressley: A Guide to Quantum Groups, Cambridge University Press, Cambridge, 1994, xv+651 pp., GBP 60.00, ISBN 0-521-43305-3

A simple description of this book could be 'all about quantum groups'. It is very nicely written at a high mathematical level. If you require some result concerning quantum groups or if you are not content with the presentation in the article about the quantum groups you are just reading, rest assured that this book will help you. In order to give some idea of the contents of the book the topics covered include: Poisson-Lie groups, Lie bialgebras, quasitensor categories, relations to links and 3-manifolds, Knizhnik-Zamolodchikov equation. The authors do not assume many prerequisites and there is even Appendix about Kac-Moody algebras so that the reader need not know much about the structure theory of Lie groups and Lie algebras. The book can be recommended as very good

for beginners. A mathematician will find here a concise and clear explanation of the physical background of various concepts. The list of references is very complete. It takes 71 pages and covers also the year 1993. My recommendation is: Go and buy the book! (jiva)

P.Griffiths, J.Harris: Principles of Algebraic Geometry, Wiley Classics Library, J.Wiley & Sons, Inc., New York, 1994, xii+813 pp., GBP 30.50, ISBN 0-471-05059-8

The book is one of the principal textbooks in the field of complex algebraic geometry. It presents the main general results of the theory, their applications to specific cases and examples as well as a description of the necessary computational techniques. The introductory chapter treats the basic techniques and results of complex manifold theory, e.g. de Rham and Dolbeault cohomology, sheaves and their cohomology, Poincaré duality, intersection theory of algebraic cycles, harmonic theory on compact complex manifolds and the theory of Kähler manifolds. In the first chapter, the theory of divisors and line bundles, vanishing cohomology theorems and also the main properties of complex algebraic varieties are given. Chapter 2 contains the theory of algebraic curves and Riemann surfaces and chapters 4 and 6 describe the theory of algebraic surfaces and quadric line complexes, including many classical results. The rest of the book covers some additional material such as distributions and currents, an introduction to the theory of characteristic classes, spectral sequences and residues together with applications to the theory of complex varieties. The book is self-contained and very well written. This is a paperback edition available to a broader circle of potential readers. It can be strongly recommended as an important source of information and a textbook for anybody interested in complex algebraic geometry and the theory of complex curves and surfaces. (jbu)

N.D.Fowkes, J.J.Mahony: An Introduction to Mathematical Modelling, J.Wiley & Sons, Inc., New York, 1994, xvi+447 pp., GBP 19.95, ISBN 0-471-93422-4, ISBN 0-471-94309-6

This book presents an expanded version of a course given mainly by the authors at the University of Western Australia. The aim of the book is to develop basic skills needed for further study of mathematical modelling. Special care was taken to present particular situations in order to illustrate mathematical techniques on simple carefully chosen examples. Significant ideas like scaling analysis leading to self-similarity are emphasized by presenting them in more than one context. Attention is also drawn to the common features of different models. A broad variety of exercises is supplied with "wizard directions" and hints encouraging the reader to solve the problems. Throughout the book basic ideas of mathematical modelling are presented. The

method of scaling analysis is illustrated by the flagpole problem and in subsequent exercises leading to study the pendulum, non-linear pendulum, sky-diving, damped vibrating string, plate vibrations and similar problems. Methods from the calculus of variations are used to study the problems of minimal path and the hanging cable solution. While studying the heat equation, the reader is taught to use energy principles and methods, the method of maximum principle and the idea of the fundamental solutions. Diffusion problems are presented in Part II together with both physical and mathematical fundamentals. Both classical and Fourier series techniques are discussed. An introduction to the finite element approach opens a discussion on numerical methods in mathematical modelling. Finally, in Part III, the reader can find vibrational and wave propagation problems, resonant systems, damped and undamped oscillations, amplitude limiting mechanisms. Signal speeds and shock wave ideas are presented by the car transmission problem. To prevent tedious technical calculations, simple programs in "Maple", a computer algebra language, are used in particular situations. This helps the authors to present ideas without spending time with technicalities. A familiarity with Maple is useful but not essential. The book is clearly written and developed logically. It is suitable for undergraduate students as well as for students of technological sciences interested in the field. (mr)

W.Bolton: Fourier Series, Mathematics for Engineers, Longman Scientific & Technical, Harlow, 1995, vii+161 pp., GBP 9.99, ISBN 0-582-23934-6

This is the fourth book of Longman's series "Mathematics for Engineers". It is aimed at first-year undergraduate students of engineering. Hence not too much is required: basic algebra, complex numbers and calculus (integration by parts, etc.). It contains many worked examples and exercises, especially those which are useful for engineers; answers are included. For teachers of calculus at universities, it could be a source of "practical examples". On the other hand it would not be useful as even a rather elementary introduction to the theory of Fourier series. (jive)

F.Orecchia, L.Chiantini (Eds.): Zero-Dimensional Schemes. Proceedings of the International Conference held in Ravello, June 8-13, 1992, Walter de Gruyter, Berlin, 1994, viii+339 pp., DM 198.00, ISBN 3-110-13934-0

The proceedings contain lectures presented at the conference and also some papers relating to problems discussed there. The book contains a survey paper, Zero-dimensional schemes: Singular curves and rational surfaces by A.V.Geramita and twenty-four contributions (lectures). They discuss many different problems concerning zero-dimensional schemes, e.g. the Castelnuovo theory, certain interpolation problems for singularities, syzygies on rational surfaces, Hilbert functions as well as related problems from combinatorics, graph theory and codes. The book also contains a list of problems and questions. It is the first book dealing exclusively with this nice topic. (jbu)

S. Alinhac: Blowup for Nonlinear Hyperbolic Equations, Progress in Nonlinear Differential Equations and Their Applications, vol. 17, Birkhäuser, Boston, 1995, xiv+112 pp., DM 78.00, ISBN 3-764-33810-5, ISBN 0-817-63810-5

This book studies the blowup mechanisms for global Cauchy problems for nonlinear hyperbolic equations and systems. Two basic local blowup mechanisms are introduced and studied, namely what the author calls "the ODE mechanism" and "the geometric blowup mechanism". Starting from basic examples of ODEs, the ODE mechanism is introduced within the context of ordinary equations, as a nonlinear self-excitation mechanism, when $|u| \rightarrow +\infty$ as x approaches a finite value c . The geometric blowup mechanism is explained using the method of characteristics for nonlinear hyperbolic problems: focusing of rays carrying the same value of solution makes $|\text{grad } u|$ become infinite while $|u|$ stays bounded. For evolutionary PDEs, where the blowup can occur when marching forward in time, the concept of lifespan is introduced as the supremum of all $t > 0$ such that $u(t)$ remains smooth for fixed smooth data. It is emphasized that both these basic blowup mechanisms can combine. Focusing mostly on whether or not there will be blowup in a solution, the methods used to study this problem are introduced and classified. Many open problems are discussed and many examples presented (Burger's equation, semilinear wave equation, quasilinear systems in one dimension, 2×2 systems, equations of nonlinear geometrical optics) which make the book readable even for those who are not expert in the field. However, some basic knowledge of PDEs, especially of hyperbolic type (existence of solutions, energy methods, ...) is supposed. The book will be valued mostly by graduate or postgraduate students interested in studying PDEs. (mr)

Y.Xu: Common Zeros of Polynomials in Several Variables and Higher Dimensional Quadrature, Pitman Research Notes in Mathematics Series, vol.312, Longman Scientific & Technical, Harlow, 1994, 119 pp., GBP 23.00, ISBN 0-582-24670-9

The theory of orthogonal polynomials in one dimension is very well known and it is one of those parts of the theory of numerical methods which leads to fully solved problems: the theory of Gauss or Gauss-type quadrature in one dimension. The situation in dimensions greater than one is very difficult to deal with, of course. Instead of points as zeros of orthogonal polynomials there must be considered such complicated zeros as curves and surfaces. In general, zeros of polynomials in d variables are algebraic varieties of dimension $d - 1$ or less. From the point of view of quadrature methods, the author studies common zeros of all polynomials of degree n , which could be distinct and real. The aim of this book is to study common zeros of families of polynomials in several variables which are related to higher dimensional quadratures. The book is suitable for postgraduate students, research workers and mathematicians, especially to those who are involved in numerical integration in more than one dimension. (mf)

C.Bandle, J.Bemelmans, M.Chipot, J.S.J.Paulin, I.Shafrir (Eds.): Elliptic and Parabolic Problems. Pont-a-Mousson 1994, Pitman Research Notes in Mathematics Series, vol.325, Longman Scientific & Technical, Harlow, 1995, 263 pp., GBP 33.00, ISBN 0-582-23961-3

C.Bandle, J.Bemelmans, M.Chipot, J.S.J.Paulin, I.Shafrir (Eds.): Calculus of Variations, Applications and Computations. Pont-a-Mousson 1994, Pitman Research Notes in Mathematics Series, vol.326, Longman Scientific & Technical, Harlow, 1995, 281 pp., GBP 36.00, ISBN 0-582-23962-1

Both these volumes contain contributions presented during the second European Conference on Elliptic and Parabolic Problems (Pont-à-Mousson, June 1994). The first volume (elliptic and parabolic problems) collects 21 lectures which can be grouped together into several different topics. There are problems connected with applications in continuum mechanics and thermodynamics (J.Carillo and A.Alonso; M.Chipot and A.Lyaghfour; P.Colli and M.Graselli; J.Escher and G.Simonett; A.L.Gladkov; J.Popiolek; H.F.Weinberger); qualitative properties of solutions (N.André; S.N.Antontsev; J.I.Diaz and S.I.Shmarev; W.Reichel; A.Simon; I.V.Skrypnik; A.I.Volpert and V.A.Volpert) and large time behaviour of solutions (A.Ito, N.Kenmochi and M.Nieźgódka; N.Sato, J.Shirozu and N.Kenmochi; E.Zuazua). Further articles discuss Calderón-Zygmund inequalities in weighted Sobolev spaces (C.Amrouche, V.Girault and J.Giroire); local weak solutions for a multivalued evolution equation (M Choulli and R.Deville); convergence of the solutions of inverse problems (V.L.Kamynin) and existence and uniqueness results for degenerate-elliptic integro-differential problems (M.A.Vivaldi).

The second volume collects 23 contributions given during the conference on calculus of variations and offers a good picture of the current state of research not only in the theoretical context but also in various applications, mainly to mechanics. Several lectures include also a discussion of numerical aspects and simulations on computers. (oj+jmil)

G.R.Kempf: Algebraic Structures, Friedrich Vieweg & Sohn, Braunschweig, 1995, x+165 pp., DM 42.00, ISBN 3-528-06583-4

The book consists of 20 chapters. The first six chapters cover the classical areas of algebra such as groups, rings and fields, modules and vector spaces. The following chapters have many interesting features: For example, the chapter on modern linear algebra begins with tensor products and ends with differential forms. The reader may be interested also in noetherian rings and localization and will find that the chapter on representations of groups is especially valuable. The text contains also many other attractive subjects (e.g. exactness of inverse limits, Lie algebras, Clifford algebras, dimension of commutative rings, efficient ways to compute Tor) as well as some supplementary basic information (e.g. Zorn's lemma, existence of algebraically closed fields). The book is well written and

will be of interest to potential users of algebra. One can also agree with the author: "Hopefully this will give a good introduction to modern algebra. I have assumed as background that the reader has learned linear algebra over the real numbers but this is not necessary." (lbe)

J.R.Whiteman (Ed.): The Mathematics of Finite Elements and Applications. Highlights 1993, J.Wiley & Sons, Inc., Chichester, 1994, xiv+424 pp., GBP 65.00, ISBN 0-471-93996-X

The book is the Proceedings of the International Conference MAFELAP 93 which took place during the period 27-30 April 1993 at Brunel University. It was the eighth conference of the famous MAFELAP series. The invited speakers of this conference were, I. Babuška, M. Crochet, C. Johnson, V. Maz'ya, K. Morgan, J. T. Oden, E. Oñate, W. L. Wendland, M. F. Wheeler and J. R. Whiteman. With the exception of that of M. Crochet, the papers resulting from the lectures of all these authors are included in this book, together with a number of abstracts of other contributions. This collection of papers gives an excellent survey of recent results, techniques and progress in the finite element method and its applications. A number of papers are devoted to new developments in adaptive methods, a posteriori error estimates, reliability of finite element computation and the application of the finite element codes on parallel computers. The applications are directed towards computational fluid dynamics, viscoelasticity, non-Newtonian flows, elastic scattering, elasto-plastic fracture analysis, high speed flow and many other subjects. The book can be warmly recommended to all specialists working in the area of the finite element method and its applications. (mf)

B.Fuchssteiner, K.Gottheil, A.Kemper, O.Kluge, K.Morisse, H.Naundorf, G.Oevel, T.Schulze, W.Wiwianka: MuPAD - Multi Processing Algebra Data Tool. Tutorial, Birkhäuser, Basel, 1994, vi+197 pp., DM 48.00, ISBN 3-764-35017-2, ISBN 0-817-65017-2

Computer algebra (CA) systems like Mathematica or Maple will have to compete with MuPAD, a younger brother born in the University of Paderborn, Germany. Problems relating to nonlinear systems resulted in the development of the new tool for fast and efficient handling of large data. MuPAD is a parallel CA system, but the user manual under review concerns a sequential version for UNIX and Macintosh OS. Arithmetic of arbitrary length is provided by incorporating the powerful PARI system. Many functions are implemented in the kernel of the system and a higher level programming language is available for comfortable programming. Great care is given to interfaces; for X an on-line hypertext help system based on HyTeX is available and much more can be expected in a short time. MuPAD is subject to copyright but it has a special distribution policy: to scientific and educational non-profit organizations it is available free of charge (a licence has to be acquired). Another advantage: beginning with version 2.0, research groups from the CA field, under some restrictions, have access to the source code

of MuPAD system. The manual under review is based on the idea of "learning by doing" and the on-line help supports this strategy. It contains a sample session chapter, examples of programs, a summary of the system and a chapter about tools and user interfaces. A list of functionality items of the system is included and an index helps to find answers to users problems. Users of Maple will find the use of system very easy. Recommended to all academic institutions which want to keep in touch with the young and fast developing field of CA systems and cannot for example afford the Mathematica market policy. (jive)

C.K.Cheung, J.Harer: Multivariable Calculus with Maple V. Preliminary Edition, J.Wiley & Sons, Inc., New York, 1994, xiv+366 pp., GBP 16.50, ISBN 0-471-59835-6

This book is one of the attempts to integrate the use of a computer algebra system — Maple V — into the learning process. As with most similar textbooks this book does not require students who are Maple experts. The text covers only a part of a calculus course — multivariable calculus. The use of Maple is the reason why topics which are appropriate for visualization are emphasized. The book contains 28 modules. Modules 1–13 help students visualize the graphs of functions and develop their geometric intuition for curves, surfaces and vector fields. Maybe, this part of the book is more detailed than necessary. Modules 14–17 cover various properties of gradient, extreme points and the method of Lagrange multipliers. Modules 18–28 cover various types of integrals and Stokes' theorem. There are three sorts of exercises in the book. Most modules contain a section named Drill Exercises. These exercises are standard calculus course exercises and do not require the use of a computer. The answers of these exercises are presented at the end of the book. The second kind of exercises are Module Exercises which are computer oriented and are meant to be done as homework. The third sort of exercises — Worksheets — tests immediately students' understanding of the topic. The nice Maple commands index is included. The book is recommended to teachers of calculus. (mli)

A.Quarteroni, A.Valli: Numerical Approximation of Partial Differential Equations, Springer Series in Computational Mathematics 23, Springer-Verlag, Berlin, 1994, xvi+543 pp., 59 fig., DM 128.00, ISBN 3-540-57111-6, ISBN 0-387-57111-6

The book deals with the numerical approximation of partial differential equations. Starting from a variational formulation of PDEs, a comprehensive theory of Galerkin methods and its variants (Petrov-Galerkin, discontinuous Galerkin methods) is developed. The theory then continues to focus on two of numerical realizations of the general Galerkin approach: the finite element method and the spectral method. Finite difference methods and fractional step schemes are presented in the framework of convection-diffusion problems and hyperbolic equations. The stability and convergence analysis of the methods studied are presented, as well as error bounds. Moreover, the

algorithmic aspects of numerical methods are discussed. The book is structured into the parts and chapters according to families of problems to be solved. In the second chapter, devoted to the solution of linear systems, standard methods such as Jacobi, Gauss-Seidel, SOR, conjugate-gradient method and multigrid method are studied. Elliptic problems are then solved by both Galerkin and collocation methods, and by mixed and hybrid methods. Galerkin and finite difference methods are discussed with respect to the solution of steady advection-diffusion problems. Further, ways of approximating the solutions of Stokes and Navier-Stokes equations are discussed with respect to Galerkin, spectral and finite difference methods. Finally, an approximation of initial boundary-valued problems (as parabolic problems in general, unsteady advection-diffusion problem and unsteady [incompressible and coimpressible] Navier-Stokes problem) as well as hyperbolic problems are discussed. The book is well written and will be valuable both for graduate or postgraduate students and specialists in the field as a handy and nicely written monograph. (mr)

R.Fraga (Ed.): Calculus Problems for a New Century. Resources for Calculus Collection, volume 2, MAA Notes and Report Series, Number 28, The Mathematical Association of America, Washington, D.C., 1993, xvi+427 pp., ISBN 0-883-85084-2

This volume of MAA Notes is a collection of exercises for a calculus course which respects the existence of computer algebra systems — systems which are able to do difficult computations or symbolic manipulations. These exercises try to emphasize conceptual understanding over rote drill and to prefer graphs and tables over rules to define functions that correspond to real world data. An organization of exercises in groups is the same as the organization of ideas in traditional calculus course. The commentaries which accompany the exercises often contain not only an answer to the question, but also a way in which the problem can be extended, how it can be viewed in a different context, or some historical notes. This book is recommended to all teachers of calculus as a supplement to a textbook. (mli)

J.Casey, M.J.Crochet (Eds.): Theoretical, Experimental and Numerical Contributions to the Mechanics of Fluids and Solids. A Collection of Papers in Honor of Paul M. Naghdi, ZAMP special issue, vol.46 (1995), Birkhäuser, Basel, 1995, 848 pp., DM 418.00, ISBN 3-764-35139-X, ISBN 0-817-65139-X

This collection of papers in honour of Paul M. Naghdi, written by his former students and colleagues, does justice to the breadth and depth of Naghdi's research. The editors provide an introduction to the volume that detail the landmark contributions that Professor Naghdi has made to the field of continuum mechanics. Also, a list of Naghdi's publications, more than two hundred papers in all covering the whole gamut from experiments to theory, is provided. The papers are uniformly good and are of archival quality. The contributions also constitute original research that do not represent a rehash or summary of previous work done by the

authors. Most areas in which Naghdi worked are reflected, although perhaps the volume could contain more contributions to the areas of mixture theory and continuum thermodynamics. As the papers cover many diverse areas, the volume in itself does not have a narrow special theme, and is more like an agglomeration of issues of journals devoted to distinct areas rather than a reference book in any particular area. (jma)

A.L.Onishchik, E.B.Vinberg (Eds.): Lie Groups and Lie Algebras III. Structure of Lie Groups and Lie Algebras, Encyclopaedia of Mathematical Sciences, vol.41, Springer-Verlag, Berlin, 1994, 248 pp., 1 fig., DM 144.00, ISBN 3-540-54683-9, ISBN 0-387-54683-9

This volume of the series is devoted mainly to the structure and classification of finite dimensional complex and real semisimple Lie groups and algebras. As usual it was necessary to include many general results on Lie groups and Lie algebras as well as the investigation of solvable and nilpotent Lie groups and Lie algebras. It is important to mention that the authors included interesting chapters "Models of Exceptional Lie Algebras" and "Subgroups and Subalgebras of Semisimple Lie Groups and Lie Algebras". There is also a chapter dealing with Lie algebras and Lie groups of small dimensions and with deformations of Lie algebras. The reader can learn in this volume a lot about the topology of Lie groups and about the relations with algebraic groups. The authors write in the introduction that they have tried, whenever possible, to give the reader the ideas of the proof and on this point they were very successful. They also included many recent results. Reading this volume you have a good feeling that you learn and understand a lot and that you proceed quite quickly. An index of notation would help but it is not included. In the end it should be mentioned that other topics such as the systematic exposition of representations of Lie groups and Lie algebras, Lie algebras over fields of finite characteristic, Lie supergroups and Lie superalgebras will be dealt with in a subsequent volume: (jiva)

M.Krbec et al. (Eds.): Nonlinear Analysis, Function Spaces and Applications, vol.5, Proceedings of the Spring School held in Prague, May 1994, Prometheus Publ. House, Prague 1994, ISBN 80-85849-69-0

The series of Spring Schools "Nonlinear Analysis, Functions Spaces and Applications" was started by A. Kufner and late S. Fučík in 1978 and has been held at different venues in the Czech Republic every four years ever since. The school traditionally consists of eight main courses of lectures presented by invited speakers. The Proceedings of the fifth Spring School, which was devoted to the memory of S. Fučík, contains seven of the main lectures. All papers are high-quality comprehensive surveys on the results concerning various topics in function space theory, variational problems and PDE's. The book additionally contains a short survey of S. Fučík's contribution to nonlinear analysis written by P. Drábek and a list of short communications presented by the participants of the school. (lpi)

T.M.Rassias, J.Šimša: Finite Sums Decompositions in Mathematical Analysis, Pure and Applied Mathematics, J. Wiley & Sons, Inc., Chichester, 1995, vi+172 pp., GBP 29.95, ISBN 0-471-94827-6

The book is devoted to the representation of functions of several variables in the form of products of one variable functions. A carefully written prologue describes the development of this topic since d'Alembert. The book brings to people working in the fields such as PDEs, approximation theory or integral equations a unique source of information which up until now was scattered in many articles. The first chapter describes Wronski, Gram and Casorati determinants, the following two chapters deal with decomposition theorems for functions of one and several variables. After a study of finite-dimensional spaces of smooth functions the remaining material is divided into four chapters on decomposition and approximate decomposition of smooth functions, the best L^2 -approximation of functions and the geometry of d'Alembert's equation. Special attention is given to the connection with the 13th Hilbert problem. Good typesetting helps one to read technical parts with complicated formulae. Recommended also for people with a general interest in mathematical analysis. (jive)

G.Grätzer: Math into LaTeX: An Introduction to LaTeX & AMS-LaTeX, Birkhäuser, Boston, 1996, xxvii+451 pp., DM 88.00, ISBN 0-817-63805-9, ISBN 3-764-33805-9

Many books on TeX have appeared since it became the major tool for writing mathematical and technical texts of various kinds. Don Knuth's very flexible `plain.tex` was considered by many people to be not completely easy to master. The package `latex.tex` (originally due to Lamport, now the LaTeX3 team) is more and more used by people wanting to use TeX and without having to spend too much time learning it. The book under review is just the book for them. Well organized material accompanied by many examples introduces a beginner into the secrets of LaTeX; the book fully respects the substantial changes which have brought to "old LaTeX" a greater flexibility and closer connection to AmSTeX. Writing a sufficiently long math text (lecture notes, monographs) by a non-expert TeX writer wanting to produce a text of a good typographical quality requires the use of a well-documented package. Grätzer's book is a solution. For a more advanced TeX user it offers a discussion of AmS and LaTeX packages, customization and advice concerning compilation of long bibliographies and indexes. In nine appendices the book contains besides useful tables of symbols (available at other places) also advice on how to use PostScript (and other) fonts, where to find updates of packages and other TeXware, how to convert texts written for other packages (`plain.tex`, "oldlatex", `amstex.tex` ...) and other useful information. (jive)

W.Bolton: Differentiation and Integration, Mathematics for Engineers. Longman Scientific & Technical, Harlow, 1995. 238 pp., GBP 11.99, ISBN 0-582-25180-X

The book appears in the series "Mathematics for Engineers". It is concerned with basic differentiation and

integration and aimed at readers for whom mathematics is important but not their primary interest. Hence it is more a (good) cookbook than a textbook on the theoretical aspects. Simple examples, mostly with a practical background, are used to explain basic notions. Besides the standard obvious subjects the reader will find chapters on applications (numerical differentiation and integration, areas and volumes, moments, mean values), also an appendix on supporting mathematics is included. The book is concentrated on worked examples and contains many problems, all with solutions provided (358, but in fact twice more since some problems contain more exercises of a similar type). The book also contains many instructive pictures. As well as for teaching at technical universities it could be useful also for teachers wanting to show the practical aspects of using basic calculus techniques. (jive)

T.Ransford: Potential Theory in the Complex Plane, London Mathematical Society Student Texts 28, Cambridge University Press, Cambridge, 1995, x+232 pp., GBP 29.95, ISBN 0-521-46120-0, ISBN 0-521-46654-7

The book presents an exposition of the basic concepts of potential theory in the plane with an emphasis on relations to complex analysis. The first five chapters treat harmonic functions, subharmonic (=hypoharmonic) functions, logarithmic potentials of compactly supported Borel measures, (inner)polar sets, the Dirichlet problem, harmonic measure, Green's functions, capacity and the transfinite diameter, criteria for thinness and related topics. The reader is expected to have a working knowledge of elementary complex analysis and basic integration theory; required prerequisites concerning general Borel measures are collected in the appendix. The fundamentals of potential theory are carefully developed; the book provides a lucid presentation of their close connection to complex analysis which can be highly recommended to graduate students in analysis. A somewhat more demanding last chapter 6 provides additional examples of applications of potential theory (to interpolation theorems, uniform approximation, Banach algebras, complex dynamics) providing attractive reading to all analysts. (jokr)

P.M.Cohn: Skew Fields. Theory of General Division Rings, Encyclopedia of Mathematics and its Applications 57, Cambridge University Press, Cambridge, 1995, xv+500 pp., GBP 55.00, ISBN 0-521-43217-0

An up to date account of the methods and results of the theory of general division rings is presented. Attention is paid to constructions of skew fields not necessarily finite-dimensional over their centres. The book develops the matter of the author's Skew Fields Constructions from 1977. It is divided into nine chapters. The first and fourth chapters examine the existence of a field of fractions and give the necessary and sufficient conditions in the form of quasi-identities. Fields of fractions, resp. epic R -fields (for a ring R) are formed with use of the singular kernel. Here the case of Ore and Sylvester domains is treated. The classes of skew polynomial rings,

power series rings and filtered rings and fields formed from them are studied in the second chapter, while the third builds the Galois theory for skew fields. The next chapter deals, among other things, with coproduct construction for fields and Artin's problem, with the specialization lemma and its applications to free algebras and with rational identities and Bergman's theory of specializations. The results on singularities and some open problems associated with the approach to non-commutative algebraic geometry are given in the eighth chapter. The closing chapter is devoted to the study of valuations and orderings on skew fields. Each chapter contains exercises, open problems and historical notes. (tk)

P.J.Olver: Equivalence, Invariants, and Symmetry, Cambridge University Press, Cambridge, 1995, xvi+525 pp., GBP 24.95, ISBN 0-521-47811-1

The book deals with the three interconnected topics given in the title, each of them having many significant and substantial applications. The titles of the main chapters are: Geometric Foundations, Lie groups, Representation Theory (only a short introduction), Jets and Contact Transformations, Differential Invariants, Symmetries of Differential Equations, Symmetries of Variational Problems, Cartan's Equivalence Method, Prolongation of Equivalence Problems. Although the elementary foundations are given in the standard "modern" way, the presentation of the crucial parts of the book relies on the original works by S.Lie and É.Cartan. As the author says, he wants to avoid "elaborate, theoretical machinery that many have chosen to 'rigorize' the topic" and which "only serves to obscure the fundamental issues". Another feature of this book is its rather expository character: many interesting results are presented without proof, only with the reference to the original sources. The book should be warmly recommended to graduate students of mathematics and mathematical physics. (ok)

J.L.Alperin, R.B.Bell: Groups and Representations, Graduate Texts in Mathematics, vol.162, Springer-Verlag, New York, 1995, x+194 pp., DM 38.00, ISBN 0-387-94525-3, ISBN 0-387-94526-1

The book is based upon a mandatory course for all incoming mathematics graduate students at Chicago (and contains a number of historical remarks exhibiting the importance of Chicago for group theory). It highlights several aspects of groups, with the emphasis on finite groups. The authors justly feel that the general linear group serves much better as the standard example than the symmetric groups. After giving the rudimentary notions, they therefore consider the basic features of $GL(V)$ and only then move to Sylow's theorem, Schur-Zassenhaus theorem and composition series. The remaining two fifths of the book are concerned with semisimple algebras, Wedderburn theory and characters, culminating in the proof of existence of the Frobenius kernel. The book is well written and might be used by students with only basic knowledge of algebras. However, there are places in the book where such a student might wish for slightly more rigorous proofs. (ad)

W.Ballmann: Lectures on Spaces of Nonpositive Curvature with an appendix by Misha Brin. Ergodicity of Geodesic Flows, DMW Seminar Band 25, Birkhäuser, Basel, 1995, 120 pp., DM 39.80, ISBN 3-764-35242-6, ISBN 0-817-65242-6

This Lecture Note is an excellent introduction to an up-to-date topic in Riemannian geometry, namely the geometry of Hadamard spaces. Here are some selected titles of the sections: The cone at infinity and the Tits metric; The duality condition; Geodesic flows on Hadamard spaces; Harmonic functions and random walks (on some countable groups of isometries); Buseman functions and horospheres; Rank, regular vectors and flats; Proof of the rank rigidity. Here "rank rigidity" means that Hadamard spaces of rank higher than one are of very special type. The appendix written by M.Brin gives a short proof of ergodicity property for compact manifolds of strictly negative curvature. The book contains a very informative introduction, many valuable remarks, exercises and also open problems. The bibliography contains more than 300 references. (ok)

D.J.S.Robinson: A Course in the Theory of Groups. Second Edition, Graduate Texts in Mathematics, vol.80, Springer-Verlag, New York, 1996, xvii+499 pp., 40 fig., DM 88.00, ISBN 0-387-94461-3

Robinson's book is one of several comprehensive introductions to the theory of groups that are currently in use. It stands out by emphasizing structural aspects and thus is a good departure point for those who are interested in group extensions and infinite groups. The first ten chapters are standard (abelian, solvable, nilpotent, free, primitive and multiply transitive groups together with transfer and rudiments of representations). After a careful explanation of the foundations of extensions and group cohomologies, there are four chapters concerned with general structural problems (locally finite, nilpotent and solvable groups, subnormal subgroups, maximal and minimal condition, Engel groups, infinite soluble groups and some information on Burnside problems). The current Second Edition differs from the First Edition (1982) only in a local way. The book is pleasant to work with and contains numerous exercises. (ad)

K.Taira: Analytic Semigroups and Semilinear Initial Boundary Value Problems, London Mathematical Society Lecture Note Series 223, Cambridge University Press, Cambridge, 1995, x+164 pp., GBP 20.95, ISBN 0-521-55603-1

The monograph provides an analytic semigroup approach to initial boundary value problems for semilinear parabolic equations. It focuses on proving that a second order elliptic differential operator A on a smooth bounded domain in \mathbf{R}^N generates a analytic semigroup in a properly chosen space, so that a boundary condition $Bu := a\partial u/\partial\nu + bu = \varphi$ on $\partial\Omega$ is incorporated in its domain even in the case when the problems becomes degenerate. The functions

a, b in the condition B are smooth functions on $\partial\Omega$ and $\partial/\partial\nu$ denotes a conormal derivative associated with A . To verify the conditions of the generation theorem, elliptic boundary value problems are studied in the framework of Sobolev spaces of L^p -style, by using the L^p theory of pseudo-differential operators, which form the most convenient tool in the investigation of such problems. The monograph is fairly self-contained, it includes preparatory chapters containing a brief summary of theory of analytic semigroups, Sobolev embedding theorems and L^p theory of pseudo-differential operators. The book is written for graduate students and researches with an interest in analytic semigroups and initial boundary value problems. (hpe)

J.D.P.Meldrum: Wreath Products of Groups and Semigroups, Pitman Monographs and Surveys in Pure and Applied Mathematics, vol.74, Longman Scientific & Technical, Harlow, 1995, xii+324 pp., GBP 60.00, ISBN 0-582-02693-8, ISBN 0-470-23526-8

This is the first monograph on wreath products of groups and semigroups. This important construction method plays a crucial role in fundamental theorems in both group theory (Krasner-Kaloujnine theorem) and semigroup theory (Krohn-Rhodes theorem). The book under review looks at the structure of wreath products and develops proof techniques. Wherever possible, the material is presented in the framework of permutation groups and transformation monoids. Various applications are also included. (jtu)

O.Oleinik: Some Asymptotic Problems in the Theory of Partial Differential Equations, Lezioni Lincee, Cambridge University Press, Cambridge, 1996, x+202 pp., GBP 12.95, ISBN 0-521-48537-1, ISBN 0-521-48083-3

The book contains the author's recent results in two areas of the theory of PDEs. The first one is the asymptotic behaviour of solutions of nonlinear elliptic equations (Chapters 1.-3.). The equation considered is mostly of the form $Lu - a(x)|u|^{p-1}u = f(x)$, where L is a linear elliptic operator of second order, $p > 1$. (The equation $\Delta u - e^u = 0$ is also considered.) The first chapter is devoted to the boundary problem (with Dirichlet or Neumann conditions) in unbounded domains, especially to the asymptotic behaviour of its solutions at infinity. In Chapter 2, this problem is studied for cylindrical domains. In Chapter 3, the author considers solutions in domains whose boundaries have singularities of conical type and proves theorems about the behaviour of these solutions near these singular points. The second part of the book (Chapter 4) is devoted to some new problems in homogenization of PDR: the homogenization of second order elliptic equations in partially perforated domains with both Dirichlet and Neumann condition on holes. Finally, the asymptotics of solutions and eigenvalues of the problems with rapidly alternating type of boundary conditions is studied. Most of the results are new and are published for the first time. (jkop)

SOCIÉTÉ MATHÉMATIQUE DE FRANCE REVUE ASTÉRISQUE

231 ASTÉRISQUE 1995
PETITS DIVISEURS EN DIMENSION 1 Jean-Christophe YOCOZ
SOCIÉTÉ MATHÉMATIQUE DE FRANCE

Jean-Christophe YOCOZ
Petits diviseurs en dimension 1

ISSN 0303-1179
Listprice : 250 FF (\$50)
Memberprice : 175 FF (\$35)

The first paper study wich circle diffeomorphisms commute with a diffeomorphism f whose rotation number $\rho(f)$ is irrational. When f is not smoothly conjugated to a rotation, $\rho(f)$ cannot be diophantine according to Herman's theorem; the centralizer of f is then related to the quality of rational and diophantine approximations of $\rho(f)$. Examples of diffeomorphisms wich only commute with iterates are constructed.

The dynamics of biholomorphisms in one complex variable near a fixed point is the subject of the second paper. In 1942, Siegel proved that such a germ is analytically linearizable if its linear part is a diophantine rotation; the set of rotation numbers for wich such a linearization result holds was later enlarged by Bruno. A geometrical approach allows to give a new proof of these results, and to prove their converse : if Bruno's arithmetical condition fails to be satisfied, the corresponding quadratic polynomial is not linearizable.

I. KRIZ, J.P. MAY
Operads, Algebras, Modules and Motives

ISSN 0303-1179 - Listprice : 145 FF (\$29), Memberprice : 105 FF (\$21)

With motivation from algebraic topology, algebraic geometry, and string theory, we study various topics in differential homological algebra. The work is divided in five largely independent parts : I- Definitions and examples of operads and their actions, II- Partial algebraic structures and conversion theorems, III- Derived categories from a topological point of view, IV- Rational derived categories and mixed Tate motives, V- Derived categories of modules over E^∞ algebras. In differential algebra, operads are systems of parameter chain complexes for multiplication on various types of differential graded algebras "up to homotopy", for example commutative algebras, n -Lie algebras, n -braid algebras, etc. Our primary focus is the development of the concomitant theory of modules up to homotopy and the study of both classical derived categories of modules over DGA's and derived categories of modules up to homotopy over DGA's up to homotopy. Examples of such derived categories provide the appropriate setting for one approach to mixed Tate motives in algebraic geometry, both rational and integral.

233 ASTÉRISQUE 1995
OPERADS, ALGEBRAS, MODULES AND MOTIVES I. KRIZ and J.P. MAY
SOCIÉTÉ MATHÉMATIQUE DE FRANCE

234 ASTÉRISQUE 1996
ESPACES SYMÉTRIQUES DE DRINFELD Alain GENESTIER
SOCIÉTÉ MATHÉMATIQUE DE FRANCE

Alain GENESTIER
Espaces symétriques de Drinfeld

ISSN 0303-1179
Listprice : 135 FF (\$37)
Memberprice : 95 FF (\$19)

After Drinfeld, the p -adic symmetric space $\hat{\Omega}^d$ (or, more precisely, $\hat{\Omega}^d \hat{\otimes}_{\mathcal{O}} \hat{\mathcal{O}}^{nr}$ where $\hat{\mathcal{O}}^{nr}$ is the strict Henselisation of the discrete valuation ring \mathcal{O} in its closed point) represents the moduli problem of special formal \mathcal{O}_D -modules endowed with a suitable rigidification. In this work, we will present an other approach to that result. This one will be valid only when the base ring \mathcal{O} is equal characteristic, but will allow us to obtain a local description of the universal formal \mathcal{O}_D -module. Also in the case where the base ring \mathcal{O} is of equal characteristic, we will get interested into Drinfeld's covering Σ^d , for wich we will construct an object analogous to Weil's pairing.

Autres numéros disponibles : B. Perrin-Riou, Fonctions L p -adiques des représentations p -adiques (n°229), J.-Y. Chemin, Fluides parfaits incompressibles (n°230), Recent advances in operator algebras (Orléans 1992) (n°232) Contact us for informations

Please order through your bookseller or write to :
Maison de la SMF, BP 67, 13274 Marseille cedex 09, France
Fax : (33) 1 91 26 74 64
e-mail : smf@smf.univ-mrs.fr



Series on Advances in Mathematics for Applied Sciences

Oscillations In Planar Dynamic Systems

by R Mickens

A concise presentation of the major techniques for determining analytic approximations to the solutions of planar oscillatory dynamic systems.

981-02-22920 £35 Jan 1996

Series on Advances in Mathematics for Applied Sciences

Mathematical Problems in Elasticity

Edited by R Remigio

A collection of five papers illustrating the recent trends and advances in this theory.

981-02-25768 £26 Jan 1996

Series on Optimization

Game Theory

by L Petrosjan and N Zenkevich

Contents: Matrix Games; Infinite Zero-Sum Two-Person Games; Non Zero-Sum Games; Positional Games; Differential Games.

981-02-2396X £46 Feb 1996

Collected Papers of V K Patodi

Edited by S Atiyah and M Narasimhan

Includes the celebrated joint papers on the index theorem and the Atiyah-Patodi-Singer invariant.

981-02-26594 £40 Mar 1996

Series on University Mathematics

Number Theory With Applications

by W Li

A comprehensive introduction to the subject, suitable for undergraduates.

981-02-22262 £39 Feb 1996

World Scientific Series on 20th Century Mathematics

Selected Papers of Y Manin

Edited by Y Manin

A collection of research and review articles in several areas of modern mathematics and mathematical physics published over the span of three decades.

981-02-24982 £59 Mar 1996

Finite Elasticity and Viscoelasticity

by A Drozdov

Provides a systematic and self-consistent introduction to the nonlinear continuum mechanics of solids.

981-02-24338 £61 Jan 1996

Geometry of Matrices

by Z X Wan

A state-of-art monograph covering in detail the geometry of rectangular matrices, alternate matrices, symmetric matrices, and hermitian matrices over a division ring or a field.

981-02-26381 £33 Apr 1996

World Scientific books can be ordered from good bookshops. Alternatively, to order or request further information please contact World Scientific Publishing Co., 57 Shelton St., Covent Garden, London, WC2H 9HE, UK. Fax 44 171 836 2020; Tel 44 171 836 0888; E-mail wspc@demon.co.uk

**INSTITUT DE STATISTIQUE
UNIVERSITE LIBRE DE BRUXELLES**

M. Hallin

President de l'Institut de Statistique

Applications are invited for a full-time tenured position in Statistics at the Institut de Statistique de l'Universite Libre de Bruxelles. A doctoral degree in Mathematics or Statistics is required, with an expertise in mathematical statistics and a good knowledge in time series analysis. Familiarity with econometric applications would be welcome. Applicants should have a clear research achievement, or clear potential for such achievement. A reasonable degree of fluency in French, the teaching language, is of course necessary.

The appointment will be at the equivalent of associate professor level ("Charge de Cours"). The teaching load is 135 hours a year, with a graduate audience from both the Institut de Statistique and the Departement de Mathematique. It includes two graduate courses on the analysis of time series, one on linear and nonlinear regression, one on the analysis of discrete data; the subject of a fourth one will be decided with the applicant.

The person appointed also will have to play an

important role in the organization of the various scientific activities (seminars, colloquiums, etc.) at the Institute, and as a thesis advisor.

Further information can be obtained from:

mhallin@ulb.ac.be

or at the telephone numbers below.

Applications should be sent to M. le Recteur de L'Universite, 50 avenue F.D. Roosevelt, B1050 Bruxelles Belgium, as soon as possible, but no later than September 1, 1996.

Marc Hallin
Institut de Statistique
Campus de la Plaine CP 210
Universite Libre de Bruxelles
B 1050 Bruxelles, BELGIUM

Tel: 32 2 650 5886 (office)
32 2 650 5900 (secretary)
Fax: 32 2 650 5899
E-mail: mhallin@ulb.ac.be



Arithmetic, Geometry, and Coding Theory

Proceedings of the International Conference held at Centre International de Rencontres Mathématiques (CIRM), Luminy, France, June 28 - July 2, 1993

Editors:

R. Pellikaan - M. Perret - S. G. Vlăduț

1996. 17 x 24 cm. XII, 288 pages.

With 3 figures and 2 diagrams.

Cloth DM 228,- / öS 1.779,- / sFr 218,- / approx. £ 98.00

ISBN 3-11-014616-9

Algebra

Proceedings of the IIIrd International Conference on Algebra held in Krasnoyarsk, Russia, August 23 - 28, 1993

Editors:

Yu. L. Ershov - E. I. Khukhro

V. M. Levchuk - N. D. Podufalov

1996. 17 x 24 cm. XII, 306 pages.

Cloth DM 268,- / öS 2.091,- / sFr 255,- / approx. £ 116.00

ISBN 3-11-014413-1

Algebra and Analysis

Proceedings of the International Centennial Chebotarev Conference held in Kazan, Russia, June 5 - 11, 1994

Editors:

M. M. Arslanov - A. N. Parshin

I. R. Shafarevich

1996. 17 x 24 cm. VIII, 163 pages.

Cloth 218,- / öS 1.701,- / sFr 208,- / approx. £ 94.00

ISBN 3-11-014803-X

Higher Dimensional Complex Varieties

Proceedings of the International Conference held in Trento, Italy, June 15 - 24, 1994

Editors: M. Andreatta - T. Peternell

1996. 17 x 24 cm. VIII, 381 pages.

With 4 figures and 6 tables.

Cloth DM 268,- / öS 2.091,- / sFr 255,- / approx. £ 116.00

ISBN 3-11-014503-0

Potential Theory ICPT-94

Proceedings of the International Conference on Potential Theory held in Kouty, Czech Republic, August 13 - 20, 1994

Editors:

J. Král - J. Lukeš - I. Netuka - J. Veselý

1996. 17 x 24 cm. IX, 499 pages. With 1 figure.

Cloth DM 268,- / öS 2.091,- / sFr 255,- / approx. £ 116.00

ISBN 3-11-014654-1

Ohio State University
Mathematical Research Institute
Publications

Groups, Difference Sets, and the Monster

Volume 4

Proceedings of a Special Research Quarter at the Ohio State University, Spring 1993

Editors: K. T. Arasu - J. F. Dillon

K. Harada - S. Sehgal - R. Solomon

1996. 17 x 24 cm. XIII, 461 pages.

With 19 figures and 10 tables.

Cloth DM 198,- / öS 1.545,- / sFr 190,- / approx. £ 86.00

ISBN 3-11-014791-2

Convergence in Ergodic Theory and Probability

Volume 5

Editors:

V. Bergelson - P. March - J. Rosenblatt

1996. 17 x 24 cm. XI, 445 pages.

Cloth DM 198,- / öS 1.545,- / sFr 190,- / approx. £ 86.00

ISBN 3-11-014219-8

Zentralblatt für Mathematik / Mathematics Abstracts CompactMATH CD-ROM Online Database MATH



Special offer
from Springer-Verlag to
member societies of the
European Mathematical Society
15% discount on the regular
prices listed below

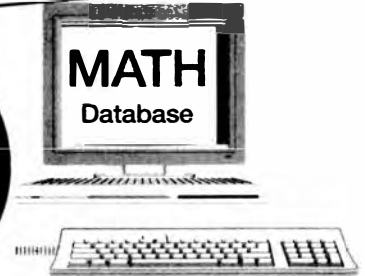

Ordering Options

Subscription combinations

(annual rates, online database: one year unlimited usage)

- | | | |
|----|----------------------|--------------|
| a) | Basic subscription: | |
| | print version | DM 7,900.-* |
| | optional components: | |
| | CompactMATH CD-ROM | DM 850.-** |
| | online database MATH | DM 850.-** |
| b) | Basic subscription: | |
| | CD-ROM | DM 7,900.-** |
| | optional components: | |
| | print version | DM 850.-* |
| | online database MATH | DM 850.-** |
| c) | Basic subscription: | |
| | online database MATH | DM 7,900.-** |
| | optional components: | |
| | CompactMATH CD-ROM | DM 850.-** |
| | print version | DM 850.-* |

Member societies of the European Mathematical Society are entitled to a 15 % reduction on the above prices.

In order to take advantage of this offer,
member societies of the EMS should contact:
Springer-Verlag
Helga-Beate Pohl
Customer Services / Distribution
Heidelberger Platz 3
D-14197 Berlin
Tel.: +49-30-82 07-3 42
Fax: +49-30-82 07-4 48

Additional copies

Print version:

Any further copy in addition to a Zentralblatt
subscription under a), b) or c) DM 370.-*

CompactMATH CD-ROM:

Any further copy in addition to a CD-ROM subscription under a), b) or c)
(including DOS retrieval module) DM 85.-**

NEW:

MATH database on the Internet

Math database is now available on the Internet

URL: <http://www.emis.de/cgi-bin/MATH>

Important features of this new service are:

- worldwide unique access to the full period from 1931 (vol. 1) to present
- on screen TEX or Postscript view of full review text
- easy menu search
- hypertext links to authors, reviewers, citations, classification, citation search,...
- hypertext access to the Mathematics Subject Classification scheme with combined navigation and search functions
- current contents of new publications
- links to the EMIS (European Mathematical Information System) server with free e-journal access, conference calendar, etc., and other services offered by FIZ Karlsruhe.

We look forward to your comments and/or suggestions: please send a message to

math-db@zbmath.fiz-karlsruhe.de

and we'll be glad to answer any questions concerning contents, technical requirements, etc.

Archive CD-ROMs (1931-1984)

Data 1931 - 1969	DM 1,735.-**
Data 1970 - 1984	DM 1,735.-**

Additional copies of the Archive CD-ROMs

Data 1931 - 1969	DM 344.-**
Data 1970 - 1984	DM 344.-**



Springer electronic media